

SHEET NO.	TOTAL SHEETS
1	109

MARSTONS MILLS VILLAGE CENTER IMPROVEMENTS

IN THE TOWN OF
BARNSTABLE
BARNSTABLE COUNTY

THE MASSACHUSETTS HIGHWAY DEPARTMENT STANDARD SPECIFICATIONS FOR HIGHWAYS AND BRIDGES DATED 1988, AS AMENDED, THE SUPPLEMENTAL SPECIFICATIONS DATED JULY 1, 2015, THE INTERIM SUPPLEMENTAL SPECIFICATIONS DATED SEPTEMBER 16, 2016, THE OCTOBER 2017 CONSTRUCTION STANDARD DETAILS, THE 1996 CONSTRUCTION AND TRAFFIC STANDARD DETAILS (AS RELATES TO TRAFFIC STANDARD DETAILS ONLY), THE LATEST EDITION OF THE MANUAL ON UNIFORM TRAFFIC CONTROL DEVICES WITH MASSACHUSETTS AMENDMENTS, THE 1990 STANDARD DRAWINGS FOR SIGNS AND SUPPORTS, THE 1968 STANDARD DRAWINGS FOR TRAFFIC SIGNALS AND HIGHWAY LIGHTING AND THE LATEST EDITION OF THE AMERICAN STANDARD FOR NURSERY STOCK, WILL GOVERN.

INDEX

SHEET NO.	DESCRIPTION
1	TITLE SHEET AND INDEX
2	LEGEND AND ABBREVIATIONS
3-4	TYPICAL SECTIONS 1 - 2
5-14	CONSTRUCTION NOTES AND DETAILS 1 - 10
15-22	CONSTRUCTION PLANS 1 - 8
23-30	DRAINAGE AND UTILITY PLANS 1 - 8
31-38	PROFILES 1 - 8
39-46	CURB TIE PLANS 1 - 8
47	GRADING PLAN
48-55	LANDSCAPE PLANS 1 - 8
56-63	LIGHTING PLANS 1 - 8
64	LIGHTING SCHEMATICS
65	LIGHTING DETAILS
66-73	TRAFFIC SIGNS AND PAVEMENT MARKING PLANS 1 - 8
74	TRAFFIC SIGN SUMMARY
75-76	TEMPORARY TRAFFIC CONTROL PLANS 1 - 2
77-109	CROSS SECTIONS 1 - 33

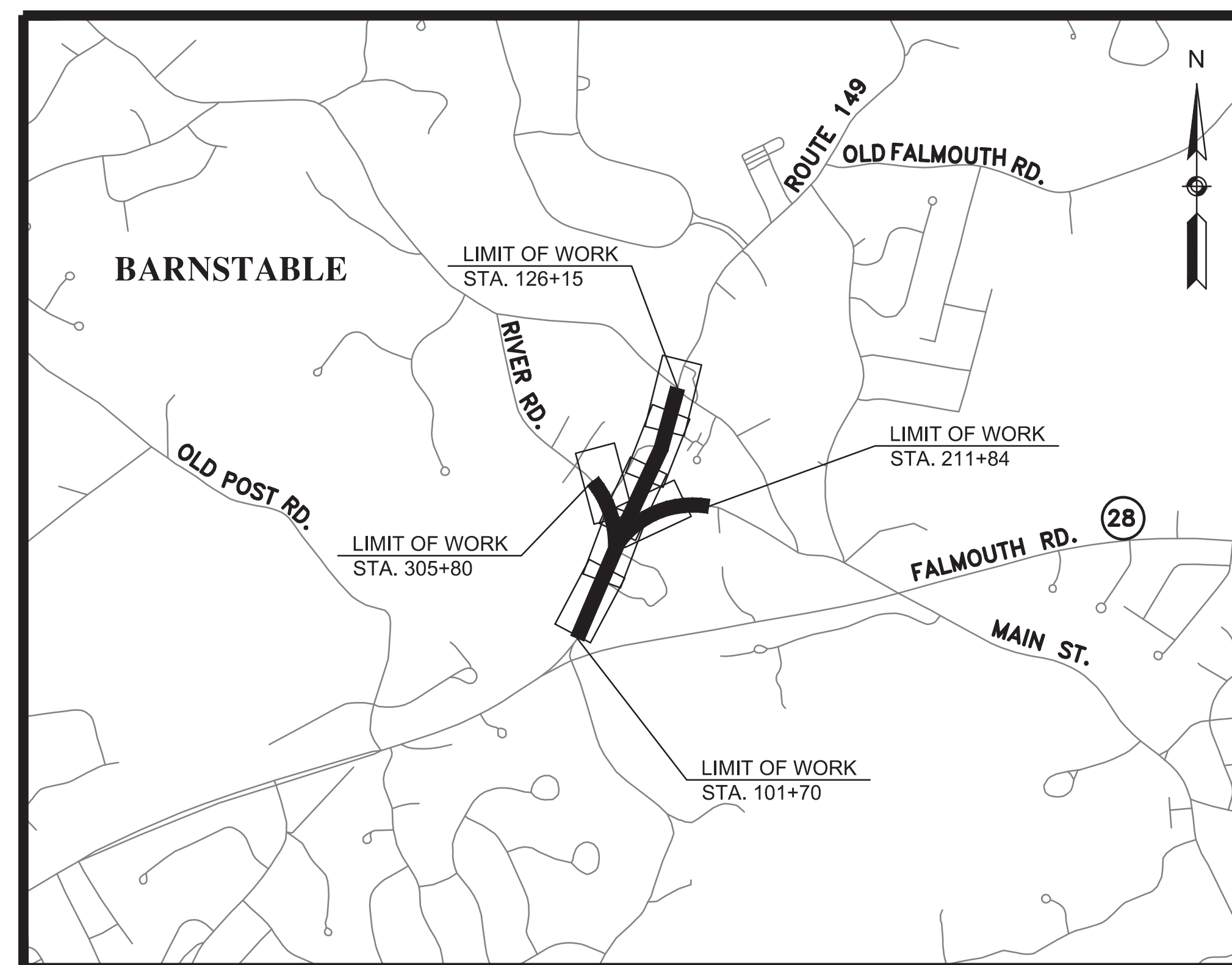

DESIGN DESIGNATION

ROUTE 149

DESIGN SPEED	25 MPH
ADT (2013)	7,550
ADT (2033)	9,250
K	12%
D	50% NB / 50% SB
T (AVERAGE DAY)	3%
DHV	1,110
DDHV	555
FUNCTIONAL CLASSIFICATION	URBAN MINOR ARTERIAL



FOR SHEETS
1-8, 15-22,
31-47, 66-109

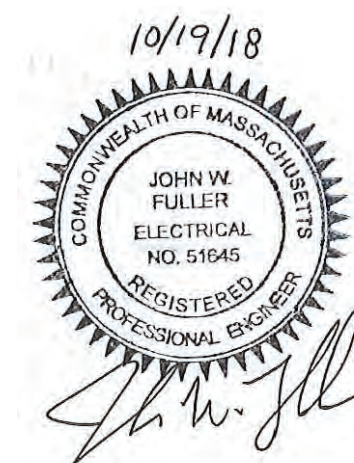

FOR SHEETS
56-65



FOR SHEETS
9-14, 23-30,
48-55



FOR SHEETS
10-11
(BOARDWALK DESIGN ONLY)

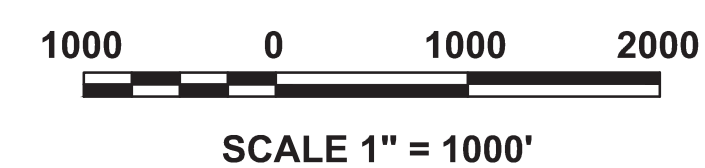

LENGTH OF PROJECT = 4209 FEET = 0.797 MILES

OCTOBER 2018

**INCLUDES REVISIONS
THROUGH 3-25-2019**



120 WATER ST
4TH FLOOR
BOSTON, MA 02109
TEL: (617) 556-0020
FAX: (617) 556-0025

350 MYLES STANDISH BLVD
SUITE 103
TAUNTON, MA 02780
TEL: (508) 823-2245
FAX: (508) 823-2246

14 BREAKNECK HILL RD
SUITE 201
LINCOLN, RI 02865
TEL: (401) 648-7200



90 Route 6A • Sandwich, MA • 02563
Tel: 508-833-6600 • Fax: 508-833-3150 • www.horsleywitten.com

LEGEND

GENERAL SYMBOLS

EXISTING	PROPOSED	
		JERSEY BARRIER ON BRIDGE OR JERSEY BARRIER
		CATCH BASIN
		CURB INLET
		BUOY
		FLAG POLE
		FLOW DIRECTION
		GAS PUMP
		DROP INLET
		MAIL BOX
		GRANITE POST
		PLANTER
		POST
		TELEPHONE BOOTH
		VAULT
		VALVE
		WELL
		ELECTRIC MANHOLE (HANDHOLE)
		GATE POST
		FLOW LINE
		GAS GATE
		BORING HOLE
		MONITORING WELL
		TEST PIT
		CONCRETE HEADWALL
		HANDHOLE
		STONE HEADWALL
		HYDRANT
		LIGHT POLE
		COUNTY BOUND
		GPS POINT
		CABLE MANHOLE
		DRAINAGE MANHOLE
		ELECTRIC MANHOLE
		GAS MANHOLE
		MISC MANHOLE
		OTHER MANHOLE
		SEWER MANHOLE
		TELEPHONE MANHOLE
		WATER MANHOLE
		MHD BOUND
		MONUMENT
		STONE BOUND
		TOWN OR CITY BOUND
		TRAVERSE OR TRIANGULATION STATION
		TRANS. POLE
		UP WITH FIREBOX
		POLE WITH DOUBLE LIGHT
		UP WITH 1 LIGHT
		UTILITY POLE
		UTILITY POLE WITH GUY
		BUSH
		TREE
		STUMP
		SWAMP / MARSH
		WATER GATE
		FIRE ALARM BOX
		PARKING METER
		ELECTRICAL GROUND
		GATE VALVE
		RIP RAP
		OVERHEAD CABLE
		DIRECT BURIAL CABLE
		CURBING
		CONTOURS
		DRAIN PIPE (DOUBLE LINE 24 INCH AND OVER)
		ELECTRIC DUCT
		GAS MAIN
		SEWER MAIN
		TELEPHONE DUCT
		WATER MAIN
		BALANCE STONE WALL
		CULVERT
		GUARD RAIL
		GUTTER LINE AT DRIVEWAYS
		CHAIN LINK FENCE

GENERAL SYMBOLS (CONT.)

EXISTING	PROPOSED	
		HAY BALES/SILT FENCE
		RETAINING WALL
		TREE LINE OR LIMIT OF CLEARING AND GRUBBING
		SAWCUT LINE
		TOP OR BOTTOM OF SLOPE
		LIMIT OF EDGE OF PAVEMENT OR COLD PLANE & OVERLAY
		LIMIT OF WORK
		BANK OF RIVER OR STREAM
		BORDER OF WETLAND
		100 FT WETLAND OR 200 FT RIVERFRONT BUFFER
		STATE HIGHWAY LAYOUT
		TOWN OR CITY LAYOUT
		COUNTY LAYOUT
		TOWN OR CITY BOUNDARY LINE
		PROPERTY LINE OR APPROXIMATE PROPERTY LINE
		EASEMENT

PAVEMENT MARKINGS AND SIGNING SYMBOLS

EXISTING	PROPOSED	
		PAVEMENT ARROW - WHITE
		LEGEND "ONLY" - WHITE
		STOP LINE - 12" - WHITE
		YIELD LINE
		CROSSWALK
		SOLID WHITE LINE - 6"
		BROKEN WHITE LINE - 6" (10' LINE, 30' SPACE)
		YELLOW GORE LINE - 12" (15' SPACING, 1:3 SLOPE)
		DOUBLE YELLOW LINE - 6"
		WHITE GORE LINE - 12"
		SOLID YELLOW LINE - 6"
		BROKEN YELLOW LINE - 6" (10' LINE, 30' SPACE)
		DOTTED WHITE LINE - 6" (2' LINE, 6' SPACE)
		DOTTED YELLOW LINE - 6" (2' LINE, 6' SPACE)

ABBREVIATIONS

GENERAL

AADT	ANNUAL AVERAGE DAILY TRAFFIC
ABAN	ABANDON
ADJ	ADJUST
APPR	APPROVED
APPROX	APPROXIMATE
A.C.	ASPHALT CONCRETE
ACCM PIPE	ASPHALT COATED CORRUGATED METAL PIPE
BIT	BITUMINOUS
BC	BOTTOM OF CURB
BD	BOUND
BL	BASELINE
BLDG	BUILDING
BM	BENCH MARK
BO	BY OTHERS
BOS	BOTTOM OF SLOPE
BR	BRIDGE
CB	CATCH BASIN
CBCI	CATCH BASIN WITH CURB INLET
CC	CEMENT CONCRETE
CCB	CAPE COD BERM
CCM	CEMENT CONCRETE MASONRY
CEM	CEMENT
CI	CURB INLET
CIP	CAST IRON PIPE
CIT	CHANGE IN TYPE
CLF	CHAIN LINK FENCE
CL	CENTERLINE
CMP	CORRUGATED METAL PIPE
CSP	CORRUGATED STEEL PIPE
CO	COUNTY
CONC	CONCRETE
CONT	CONTINUOUS
CONST	CONSTRUCTION
CR GR	CROWN GRADE
DHV	DESIGN HOURLY VOLUME
DI	DROP INLET
DIA	DIAMETER
DIP	DUCTILE IRON PIPE
DMH	DRAINAGE MANHOLE
DW	STEADY DON'T WALK - PORTLAND ORANGE
DWY	DRIVEWAY
EA	EACH
EB	EASTBOUND
ELEV (OR EL.)	ELEVATION
EMB	EMBANKMENT
EOP	EDGE OF PAVEMENT
EXIST	EXISTING
EXC	EXCAVATION
F&C	FRAME AND COVER
F&G	FRAME AND GRATE
FDN	FOUNDATION
FLDSTN	FIELDSTONE
GAR	GARAGE
GD	GROUND
GG	GAS GATE
GI	GUTTER INLET
GIP	GALVANIZED IRON PIPE
GRAN	GRANITE
GRAV	GRAVEL
GRD	GUARD
HDW	HEADWALL
HMA	HOT MIX ASPHALT
HOR	HORIZONTAL
HYD	HYDRANT
INV	INVERT
JCT	JUNCTION
K	TRUCK PERCENTAGE
L	LENGTH OF CURVE
LB	LEACHING BASIN
LP	LIGHT POLE
LT	LEFT
M.A.	MAST ARM
MAX	MAXIMUM
MB	MAIL BOX
MH	MANHOLE
MHB	MASSACHUSETTS HIGHWAY BOUND
MIN	MINIMUM
NB	NORTHBOUND
NIC	NOT IN CONTRACT
NO.	NUMBER
PC	POINT OF CURVATURE
PCC	POINT OF COMPOUND CURVATURE
PGL	PROFILE GRADE LINE
PI	POINT OF INTERSECTION
POC	POINT ON CURVE
POT	POINT ON TANGENT
PRC	POINT OF REVERSE CURVATURE
PROJ	PROJECT
PROP	PROPOSED
PSB	PLANTABLE SOIL BORROW

BARNSTABLE MARSTONS MILLS VILLAGE CENTER IMPROVEMENTS

SHEET NO.	TOTAL SHEETS
2	109

LEGEND AND ABBREVIATIONS

GENERAL (CONT.)

PT	POINT OF TANGENCY
PVC	POINT OF VERTICAL CURVATURE
PVI	POINT OF VERTICAL INTERSECTION
PVT	POINT OF VERTICAL TANGENCY
PVMT	PAVEMENT
PWW	PAVED WATER WAY
PROP	PROPOSED
R	RADIUS OF CURVATURE
R&D	REMOVE AND DISPOSE
R&R	REMOVE AND RESET
RB	RECHARGE BASIN
RCP	REINFORCED CONCRETE PIPE
RD	ROAD
RDWY	ROADWAY
REM	REMOVE
RET	RETAIN
RET WALL	RETAINING WALL
ROW	RIGHT-OF-WAY
RR	RAILROAD
R&R	REMOVE AND RESET
R&S	REMOVE AND STACK
RT	RIGHT
SB	SOUTHBOUND
SGC	SLOPED GRANITE CURB
SHLD	SHOULDER
SHLO	STATE HIGHWAY LAYOUT LINE
SMH	SEWER MANHOLE
ST	STREET
STA	STATION
STNB	STONE BOUND
SW	SIDEWALK
T	TANGENT DISTANCE OF CURVE/
TAN	TANGENT
TEMP	TEMPORARY
TC	TOP OF CURB
TLO	TOWN LAYOUT LINE
TOS	TOP OF SLOPE
TYP	TYPICAL
UNK	UNKNOWN
UP	UTILITY POLE
VAR	VARIES
VERT	VERTICAL
VC	VERTICAL CURVE
VGC	VERTICAL GRANITE CURB
WB	WESTBOUND
WCR	WHEELCHAIR RAMP
WG	WATER GATE
WIP	WROUGHT IRON PIPE
WM	WATER METER/WATER MAIN
X-SECT	CROSS SECTION

SHEET NO.	TOTAL SHEETS
3	109

**TYPICAL SECTIONS
SHEET 1 OF 2**

REV #	DATE
△	11/28/18

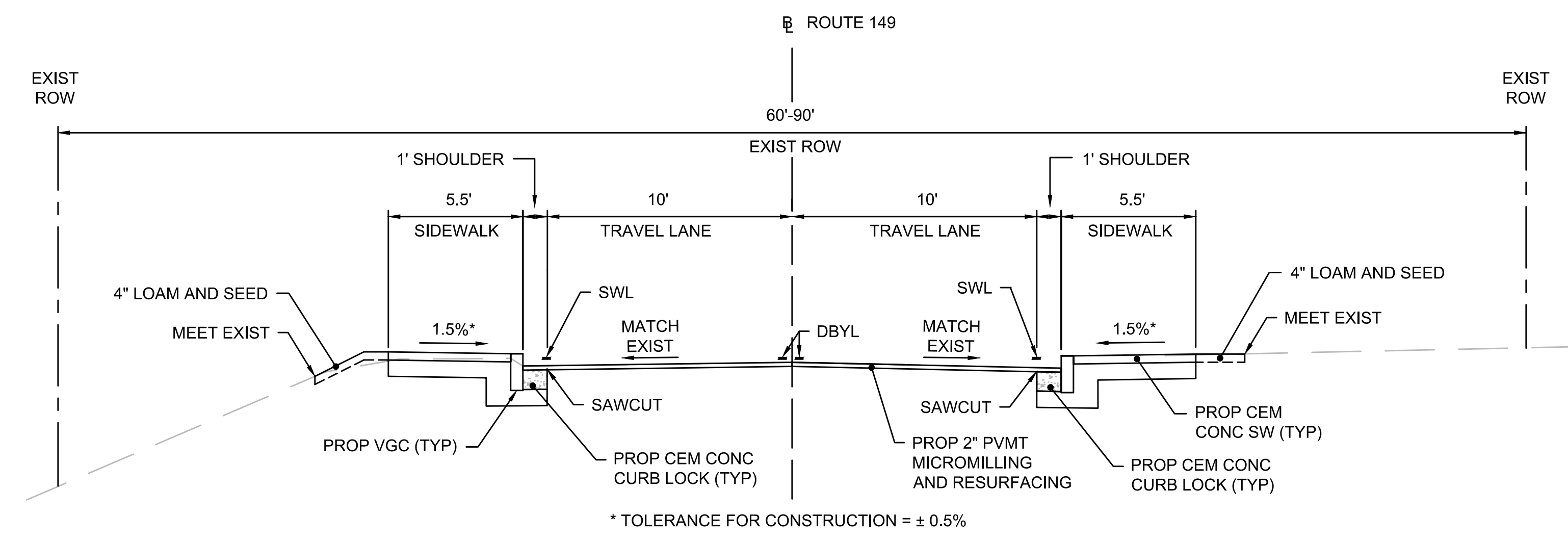

ROUTE 149
STA 101+70± TO STA 105+05±

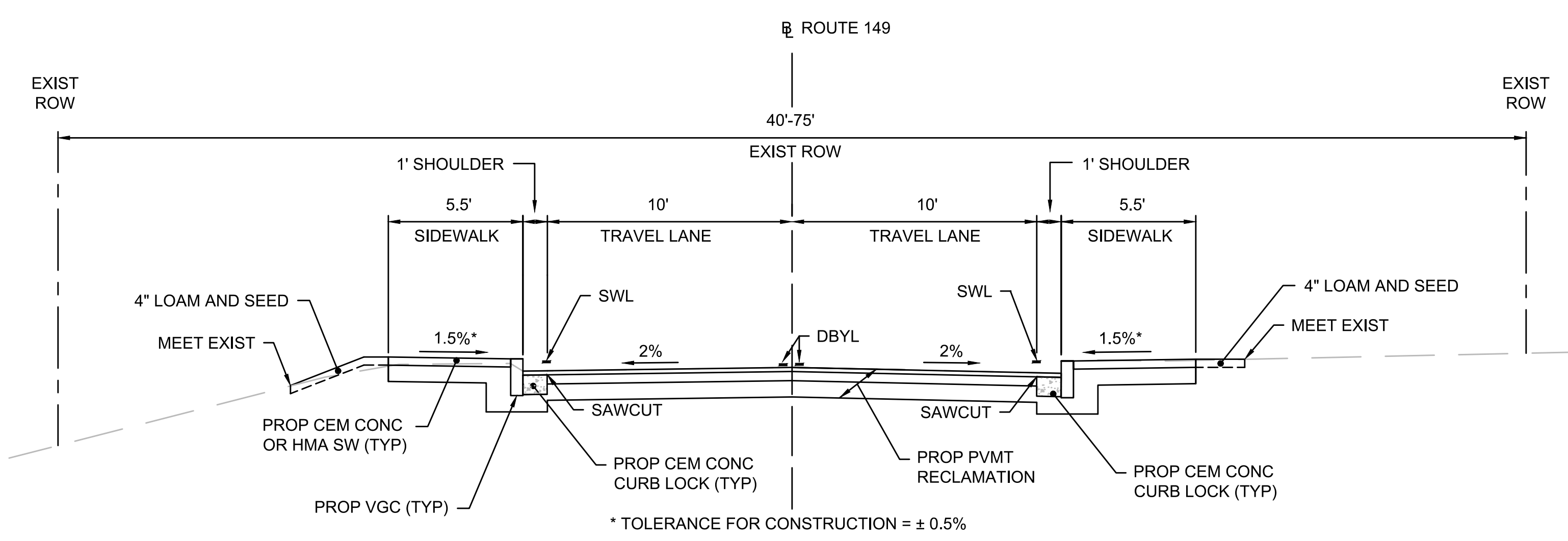

ROUTE 149
STA 105+05± TO STA 112+75±
STA 120+20± TO STA 126+15±

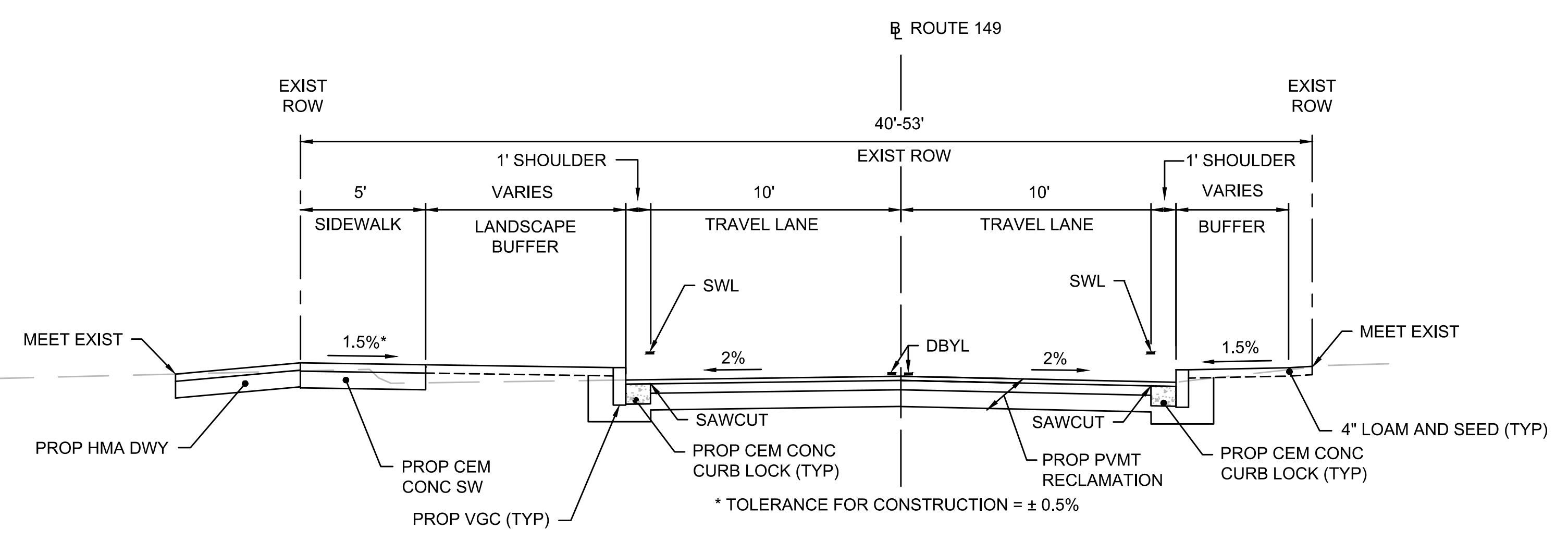

ROUTE 149
STA 112+75± TO STA 113+65±
STA 115+25± TO STA 116+15±
STA 117+65± TO STA 119+05±

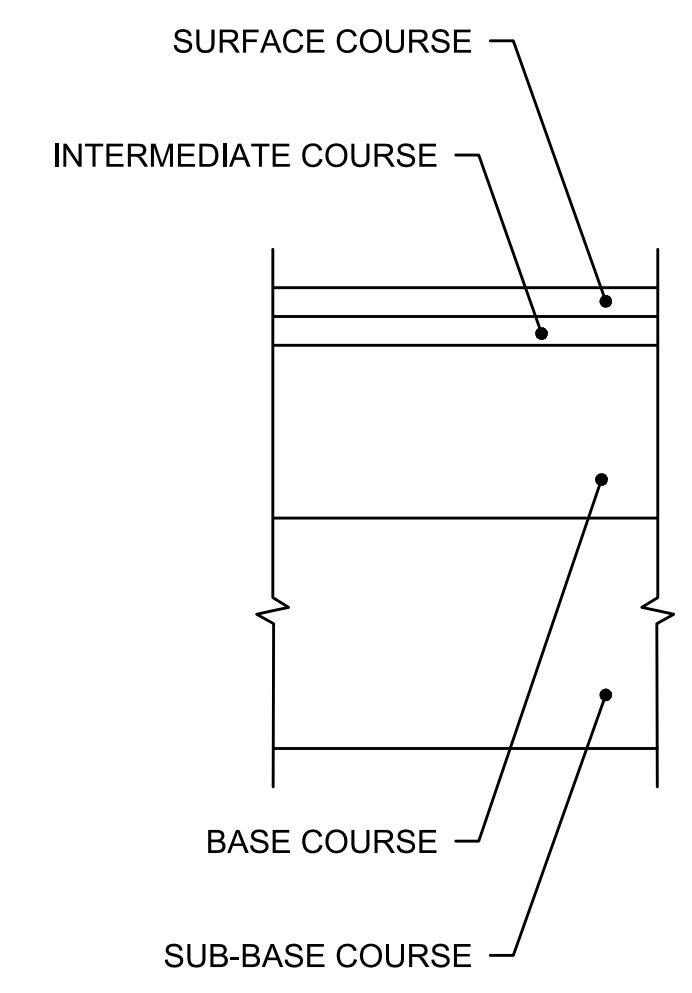
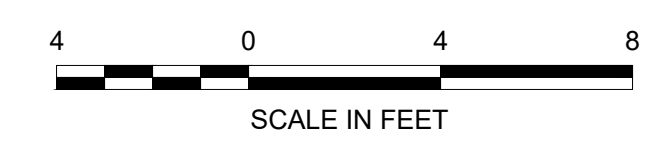

**HOT MIX ASPHALT
PAVEMENT STRUCTURE**
NOT TO SCALE

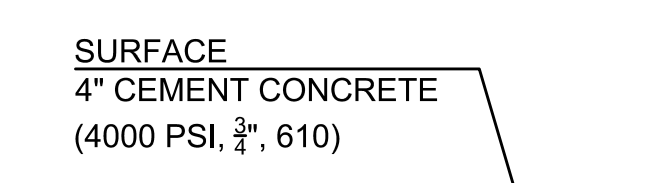

**CEMENT CONCRETE
SIDEWALK STRUCTURE**
NOT TO SCALE

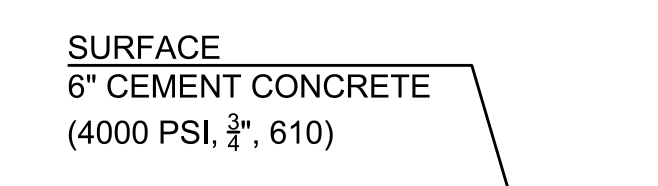

**CEMENT CONCRETE
DRIVEWAY APRON STRUCTURE**
NOT TO SCALE

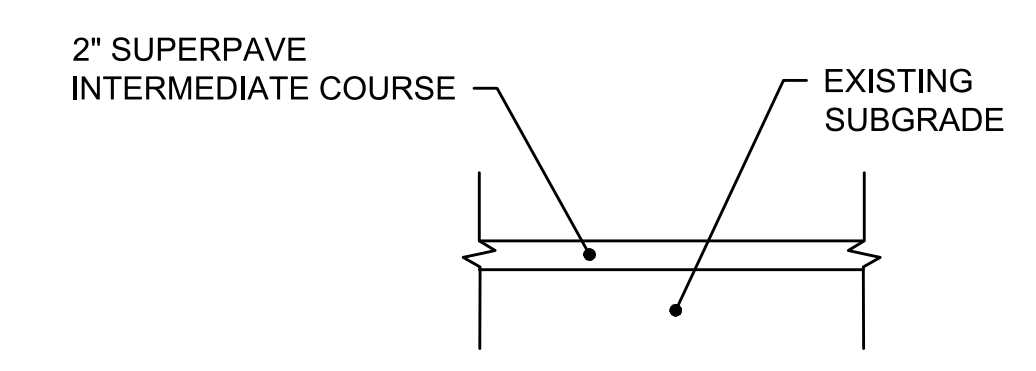

**TEMPORARY HOT MIX ASPHALT
PAVEMENT STRUCTURE**
NOT TO SCALE

PAVEMENT NOTES

PROPOSED FULL-DEPTH CONSTRUCTION AT CURBS

SURFACE: △ 2" SUPERPAVE SURFACE COURSE 12.5 (SSC-12.5) OVER ASPHALT EMULSION FOR TACK COAT (RS-1H) OVER

BASE: 6" CEMENT CONCRETE BASE COURSE OVER

SUBBASE: 8" GRAVEL BORROW FOR SUB-BASE COURSE

PROPOSED PAVEMENT RECLAMATION

SURFACE: 2" SUPERPAVE SURFACE COURSE - 12.5 (SSC-12.5)
ASPHALT EMULSION FOR TACK COAT (RS-1H)

BASE: 4.5" SUPERPAVE INTERMEDIATE COURSE - 19.0 (SIC-19.0)

SUBBASE: 8" (MIN) RECLAIMED BASE COURSE

PROPOSED PAVEMENT MICROMILLING AND RESURFACING

SURFACE: 2" SUPERPAVE SURFACE COURSE - 12.5 (SSC-12.5)
ASPHALT EMULSION FOR TACK COAT (RS-1H)
2" PAVEMENT MICROMILLING

PROPOSED HOT MIX ASPHALT DRIVEWAY AND SIDEWALK

SURFACE: 1.5" SUPERPAVE SURFACE COURSE - 9.5 (SSC-9.5)

INTERMEDIATE: 2" SUPERPAVE INTERMEDIATE COURSE - 12.5 (SIC-12.5)

SUBBASE: 8" GRAVEL BORROW (TYPE b)

PROPOSED CEMENT CONCRETE SIDEWALK

SURFACE: 4" CEMENT CONCRETE (4000 PSI, 3/4", 610)

FOUNDATION: 8" GRAVEL BORROW (TYPE b)

PROPOSED CEMENT CONCRETE DRIVEWAY APRON

SURFACE: 6" CEMENT CONCRETE (4000 PSI, 3/4", 610)

FOUNDATION: 8" GRAVEL BORROW (TYPE b)

TEMPORARY HOT MIX ASPHALT

INTERMEDIATE: 2" SUPERPAVE INTERMEDIATE COURSE - 12.5 (SIC-12.5)

NOTES:

- ALL HMA PAVING SHALL BE IN ACCORDANCE WITH SECTION 450 QUALITY ASSURANCE OF HMA SPECIFICATIONS AND SECTION 415 PAVEMENT MICROMILLING.
- ASPHALT EMULSION FOR TACK COAT (RS-1H) SHALL BE APPLIED AT A RATE OF 0.07 GAL/SY ON MILLED SURFACES AND HES CONCRETE BASE COURSE SURFACES AND 0.05 GAL/SY ON SMOOTH SURFACES PRIOR TO PAVING.
- THE SURFACE COURSE OF PAVING SHALL BE PLACED IN ONE CONTINUOUS OPERATION.
- ALL HMA PAVING SHALL BE PRODUCED WITH A WARM MIX ADDITIVE.
- EXISTING GRAVEL BORROW MEETING SPECIFICATIONS AS DETERMINED BY THE ENGINEER SHALL REMAIN, UNSUITABLE MATERIALS SHALL BE REMOVED AND REPLACED WITH GRAVEL BORROW PER STANDARD SPECIFICATIONS FOR HIGHWAYS AND BRIDGES.
- EXISTING DRIVEWAYS AND GRASS AREAS, ADJACENT TO PROPOSED IMPROVEMENTS, SHALL BE MATCHED INTO IN KIND, AS SHOWN ON THE PLANS.

SHEET NO.	TOTAL SHEETS
4	109

TYPICAL SECTIONS
SHEET 2 OF 2

REV #	DATE
1	3/13/19

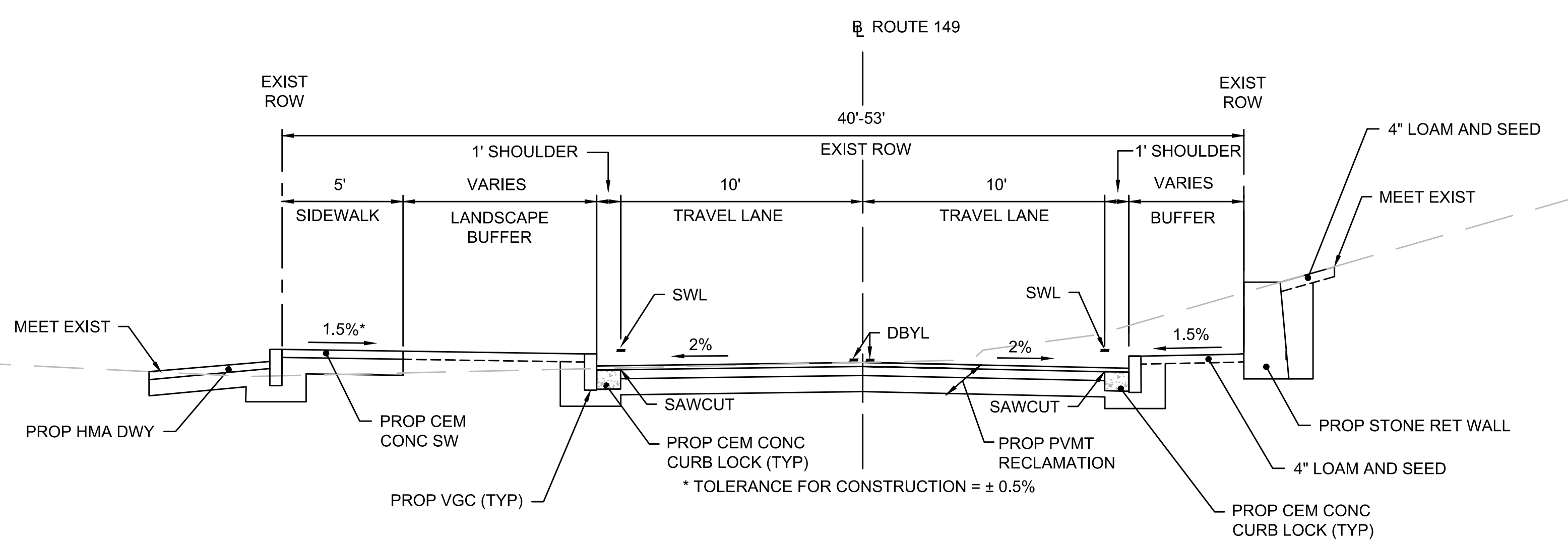

ROUTE 149
STA 113+65± TO STA 115+25±

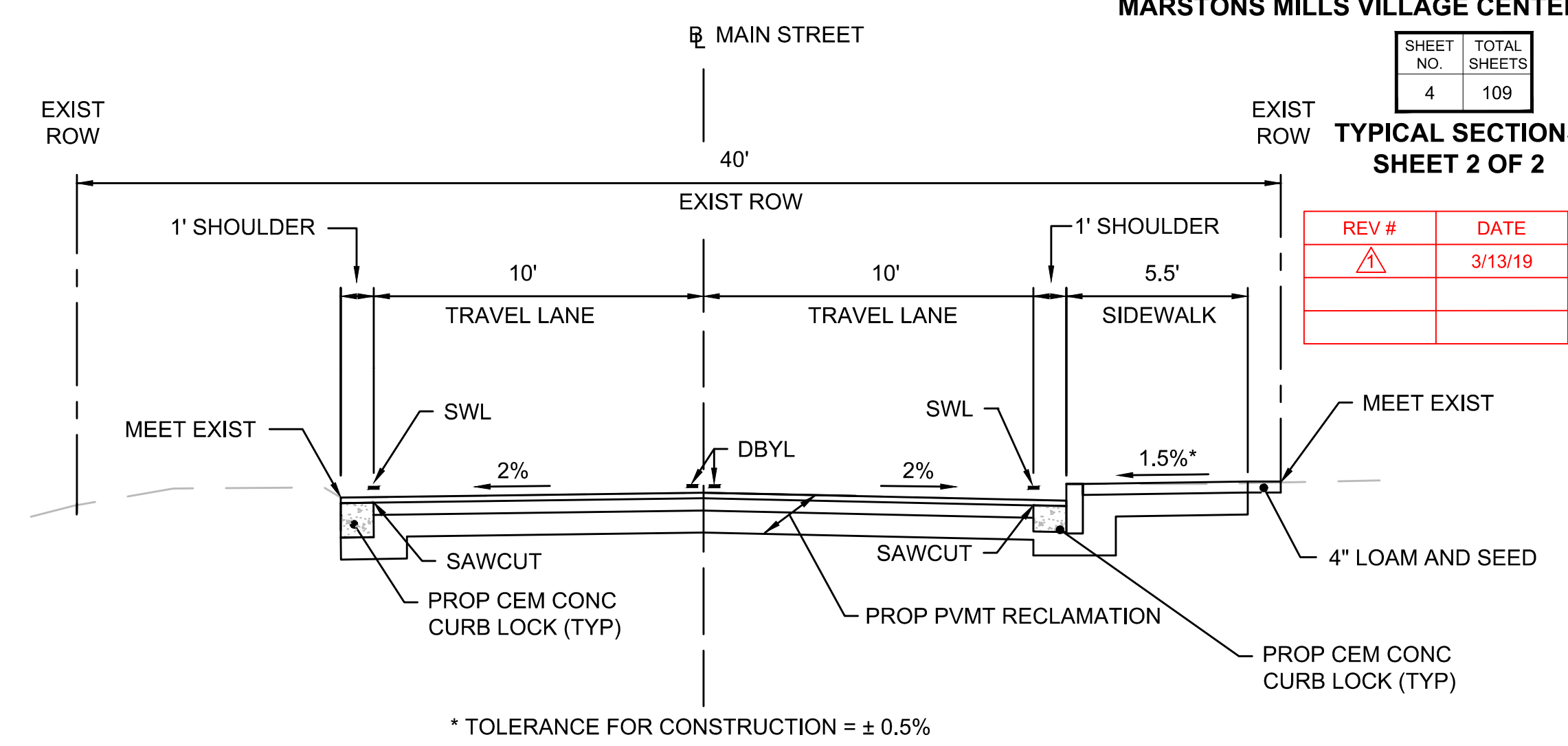

MAIN STREET
STA 203+40± TO STA 205+90±

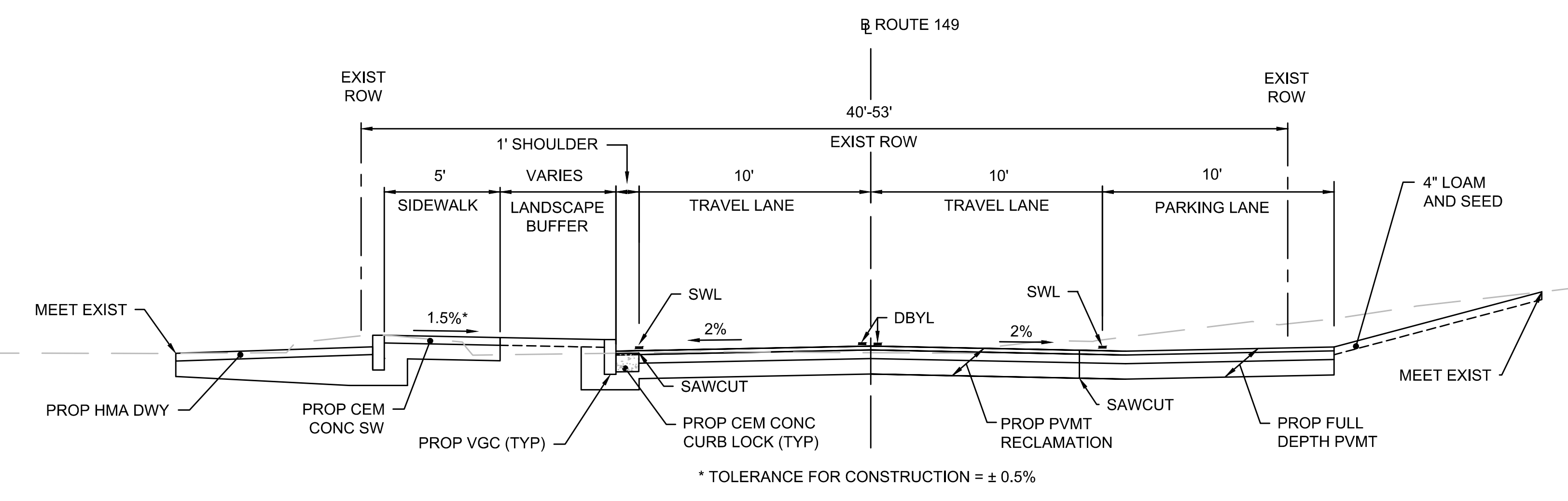

ROUTE 149
STA 116+15± TO STA 117+65±

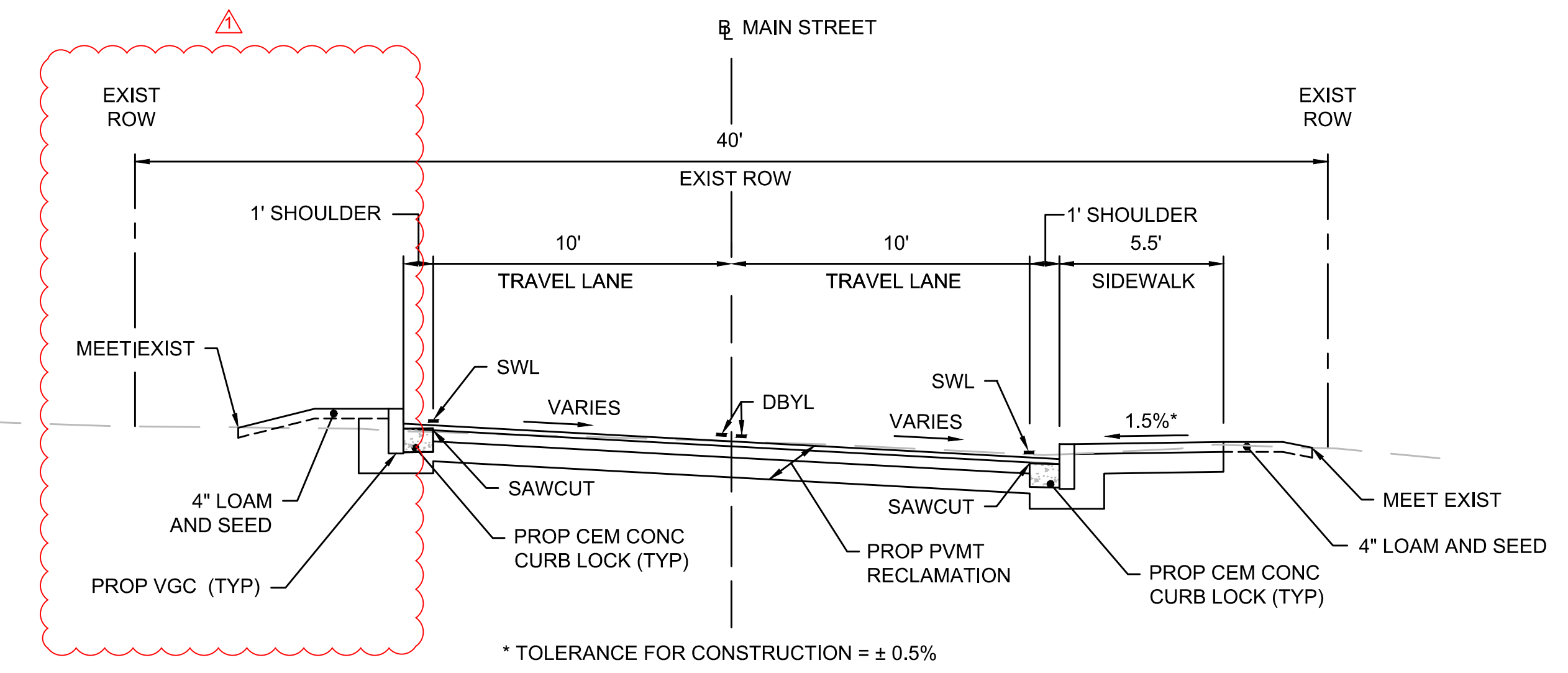

MAIN STREET
STA 205+90± TO STA 211+84±

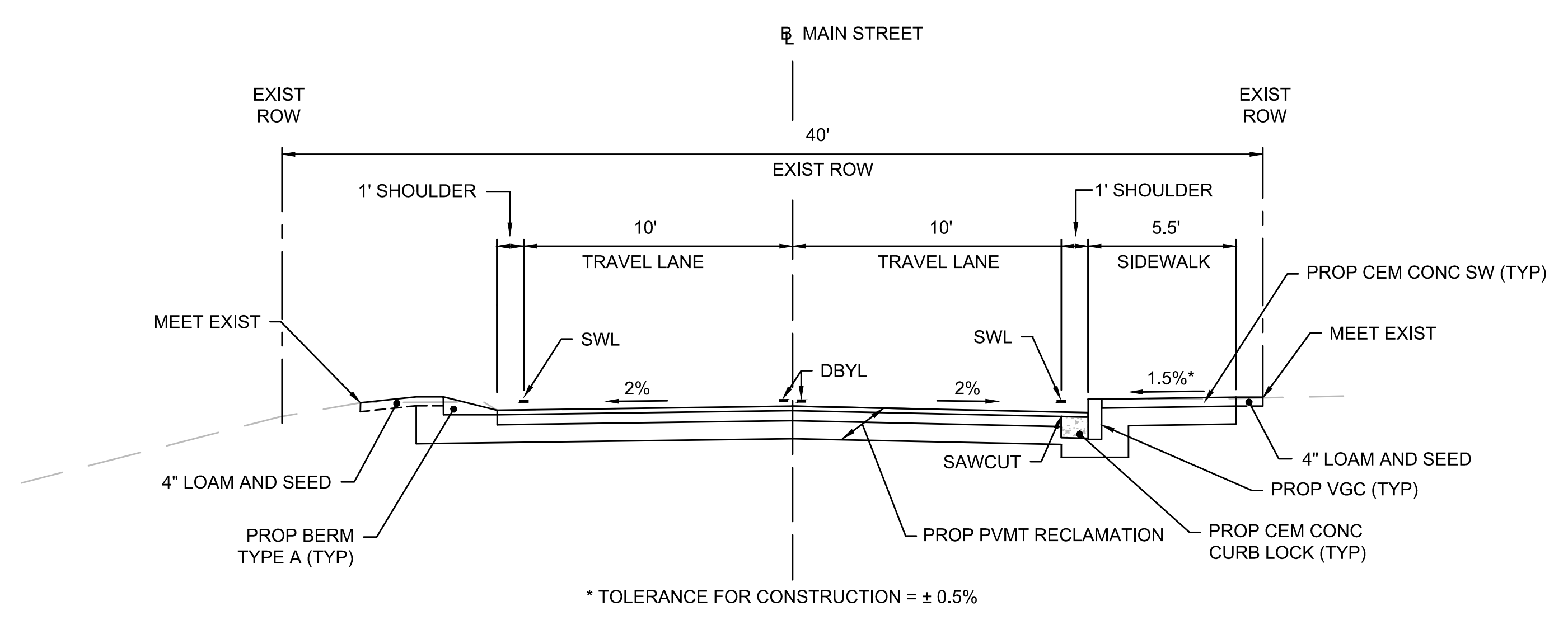

MAIN STREET
STA 201+00± TO STA 203+40±

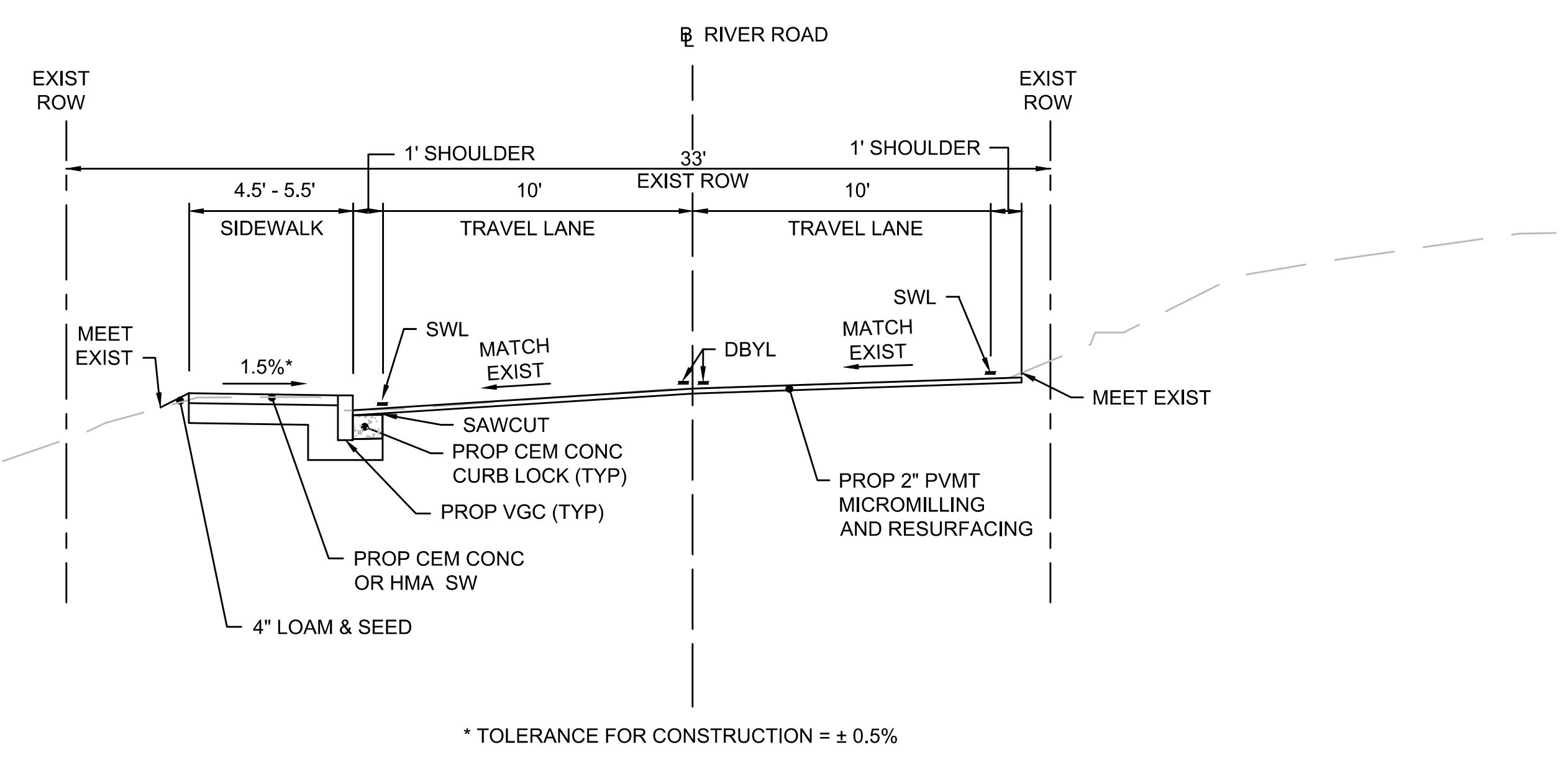

RIVER ROAD
STA 302+60± TO STA 305+80±



GENERAL NOTES:

- IT IS THE INTENT OF THE DESIGN TO PROVIDE A MINIMUM CONSTRUCTED SIDEWALK WIDTH FOR A PATH OF TRAVEL PAST ALL OBSTRUCTIONS OF 3'-0" CLEARANCE FOR HANDICAP ACCESSIBILITY (IN ACCORDANCE WITH THE LATEST A.D.A. AND MASSDOT REQUIREMENTS). THE CONTRACTOR SHALL VERIFY THAT ALL POTENTIAL OBSTRUCTIONS HAVE BEEN ADDRESSED IN THE PLANS INCLUDING BUT NOT LIMITED TO FOUNDATIONS, SIGNS, MAILBOXES, UTILITY POLES, AND HYDRANTS SO THEY ARE LOCATED TO PROVIDE THIS MINIMUM PATH OF TRAVEL CLEARANCE AND A MINIMUM 18" TYPICAL CLEARANCE TO THE FACE OF CURB OR 12" MIN. CLEARANCE WHERE 18" IS NOT FEASIBLE OR PRACTICAL. NO UTILITY POLES OR OBSTRUCTIONS ARE PERMITTED WITHIN WHEELCHAIR RAMPS.
- THE TERM "PROPOSED" (PROP) MEANS WORK TO BE CONSTRUCTED HEREIN USING NEW MATERIALS OR WHERE APPLICABLE, REUSING EXISTING MATERIALS IDENTIFIED AS "REMOVE AND RESET" (R&R). ALL OTHER MATERIALS SHALL BE "REMOVED AND DISCARDED" (R&D) OR DISPOSED OF OFF SITE WITH THE EXCEPTION OF MATERIALS LABELED AS "REMOVED AND STACKED" (R&S) WHICH SHALL BE TRANSPORTED AND AND STACKED AT A LOCATION DESIGNATED BY THE TOWN AND OR ENGINEER.
- THE CONTRACTOR SHALL PROVIDE FOR THE SAFE AND ORDERLY PASSAGE OF VEHICULAR AND PEDESTRIAN TRAFFIC IN AREAS UNDER CONSTRUCTION.
- SHOP DRAWINGS OF ALL CASTINGS, PRECAST CONCRETE STRUCTURES, PIPE AND MANUFACTURED COMPONENTS SHALL BE SUBMITTED FOR APPROVAL BEFORE ORDERING.
- ALL PROPOSED PAVEMENT MARKINGS SHALL MEET EXISTING MARKINGS AT THE LIMITS OF WORK.
- DETECTABLE WARNING PANELS SHALL BE INSTALLED ON ALL WHEELCHAIR RAMPS AND SHALL COMPLY WITH CONSTRUCTION STANDARD E 107.6.5. PAYMENT FOR DETECTABLE WARNING PANELS SHALL BE CONSIDERED INCIDENTAL TO THE CONSTRUCTION OF THE WHEELCHAIR RAMPS OR SIDEWALKS IN WHICH THEY ARE BEING INSTALLED. THE COLOR OF DETECTABLE WARNING PANELS SHALL BE AT THE DIRECTION OF THE TOWN.
- SEE SIGNS AND PAVEMENT MARKING PLANS FOR PROPOSED SIGNS AND DISPOSITION OF THE EXISTING SIGNS WITHIN THE PROJECT LIMITS OR AS DIRECTED BY THE TOWN.
- DO NOT SCALE DRAWINGS UNLESS OTHERWISE NOTED. WRITTEN DIMENSIONS SHALL PREVAIL. REPORT ANY DISCREPANCIES TO THE ENGINEER IMMEDIATELY.
- THE CONTRACTOR SHALL COMPLY WITH ALL APPLICABLE REGULATIONS OF THE OCCUPATIONAL SAFETY AND HEALTH ADMINISTRATION (OSHA).
- THE CONTRACTOR SHALL RESTORE ALL PUBLIC AND PRIVATE PROPERTY TO ITS PRE-CONSTRUCTION CONDITION AT NO ADDITIONAL COST TO THE TOWN.

**BARNSTABLE
MARSTONS MILLS VILLAGE CENTER IMPROVEMENTS**

SHEET NO.	TOTAL SHEETS
5	109

**CONSTRUCTION NOTES AND DETAILS
SHEET 1 OF 10**

REV #	DATE
1	11/28/18

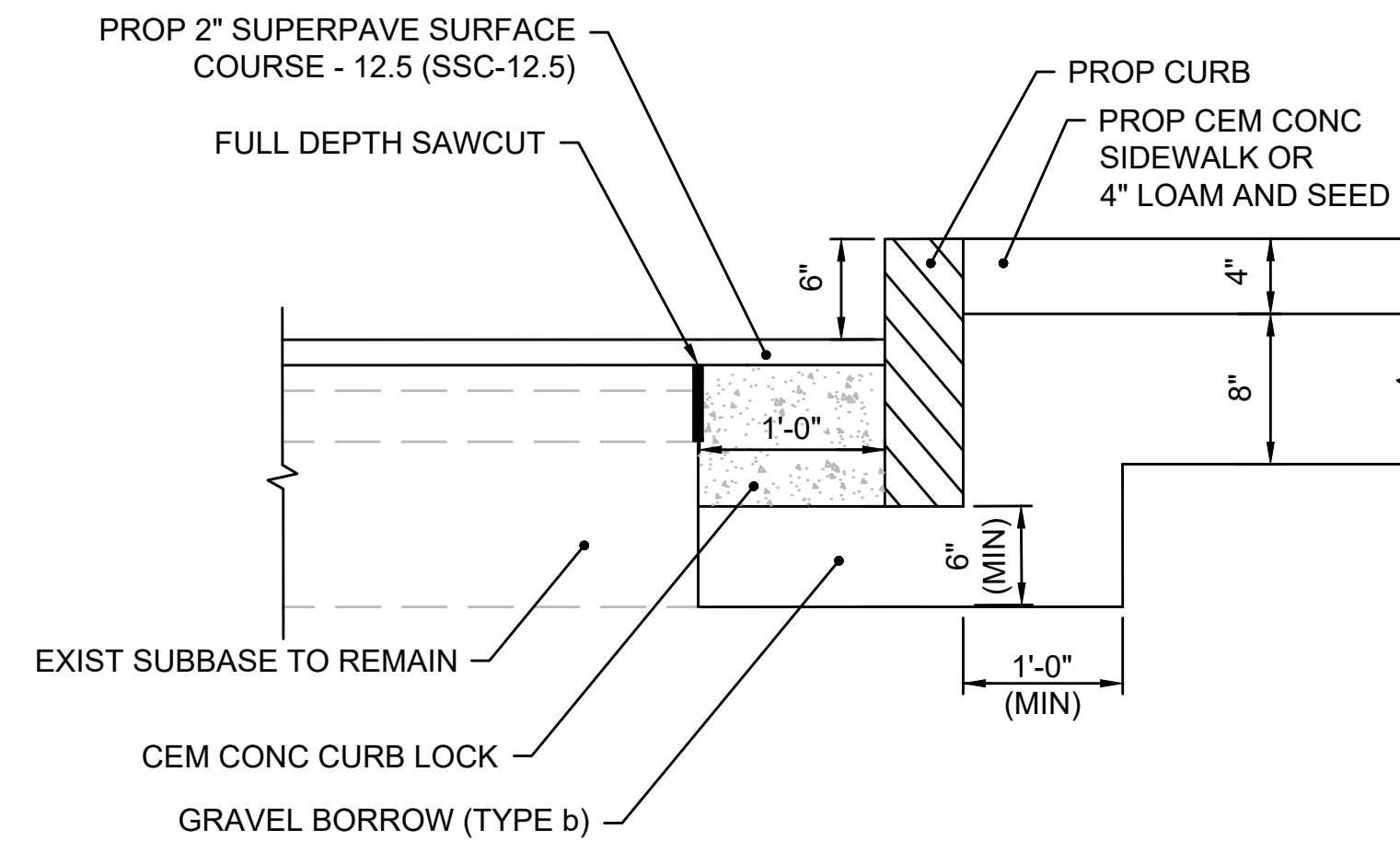

CURB SETTING
NOT TO SCALE

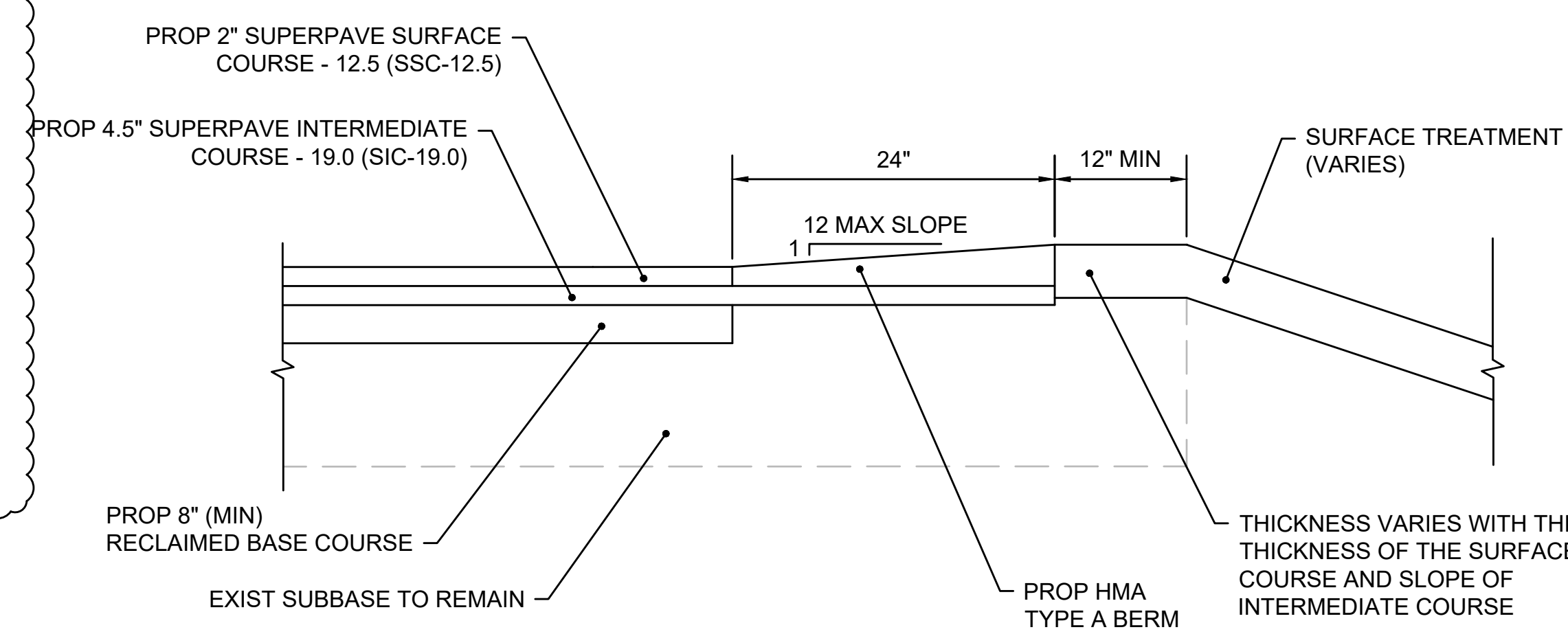

BERM TYPE A
NOT TO SCALE

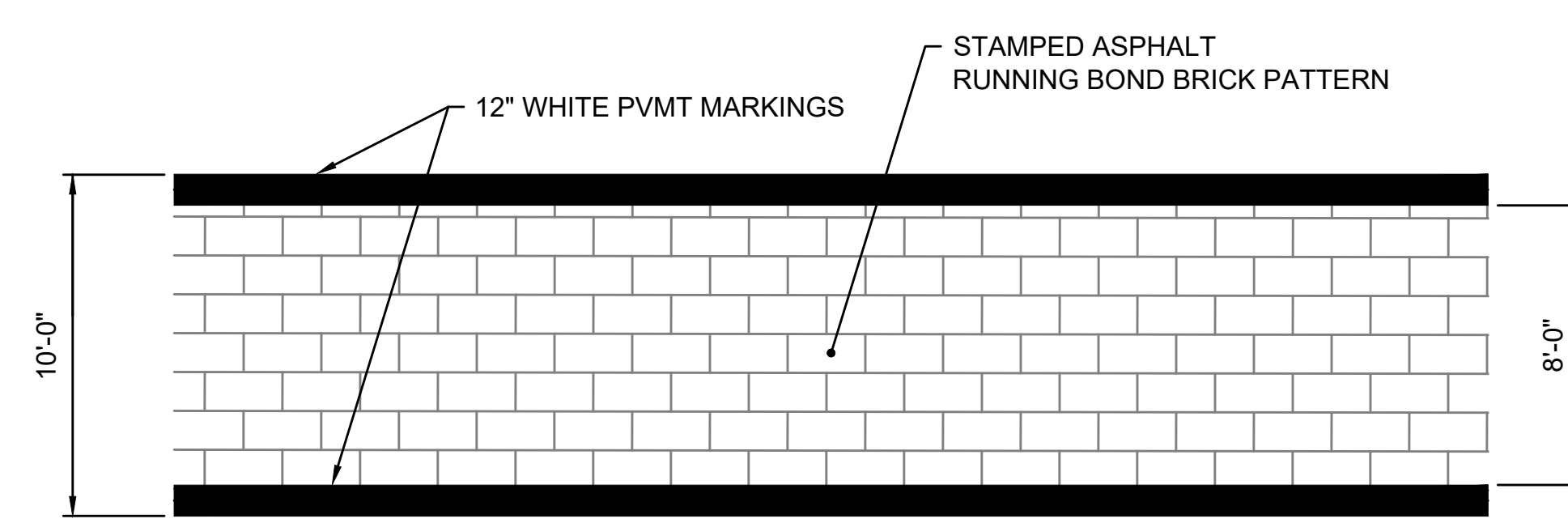

AT GRADE CROSSWALK
NOT TO SCALE

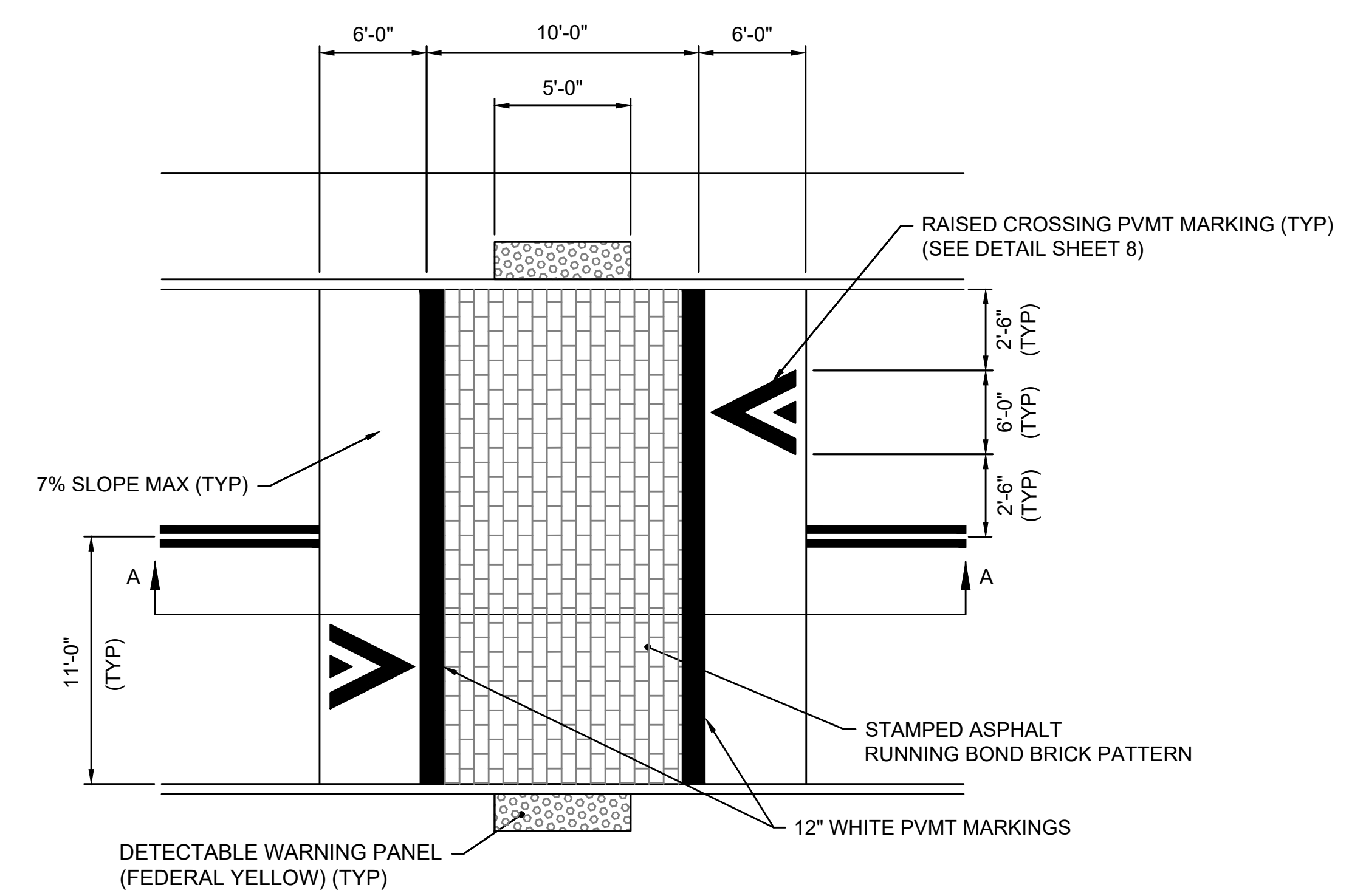

RAISED CROSSWALK
NOT TO SCALE

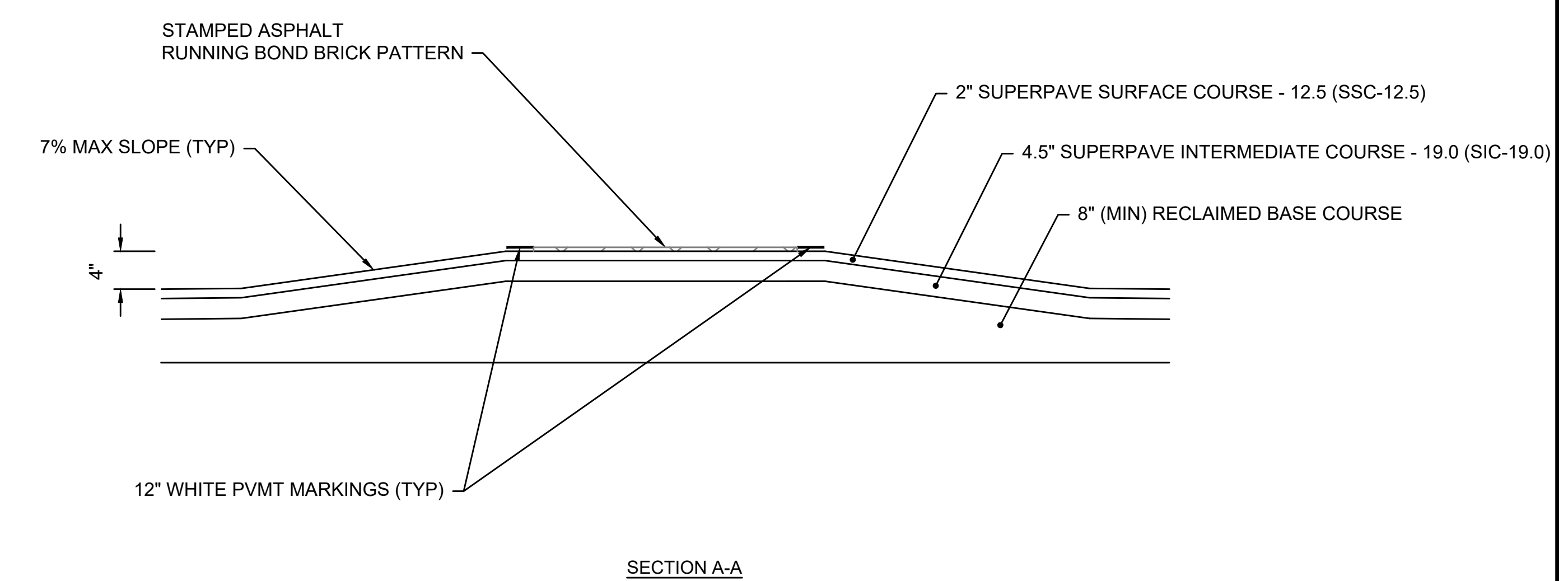

SHEET NO.	TOTAL SHEETS
6	109

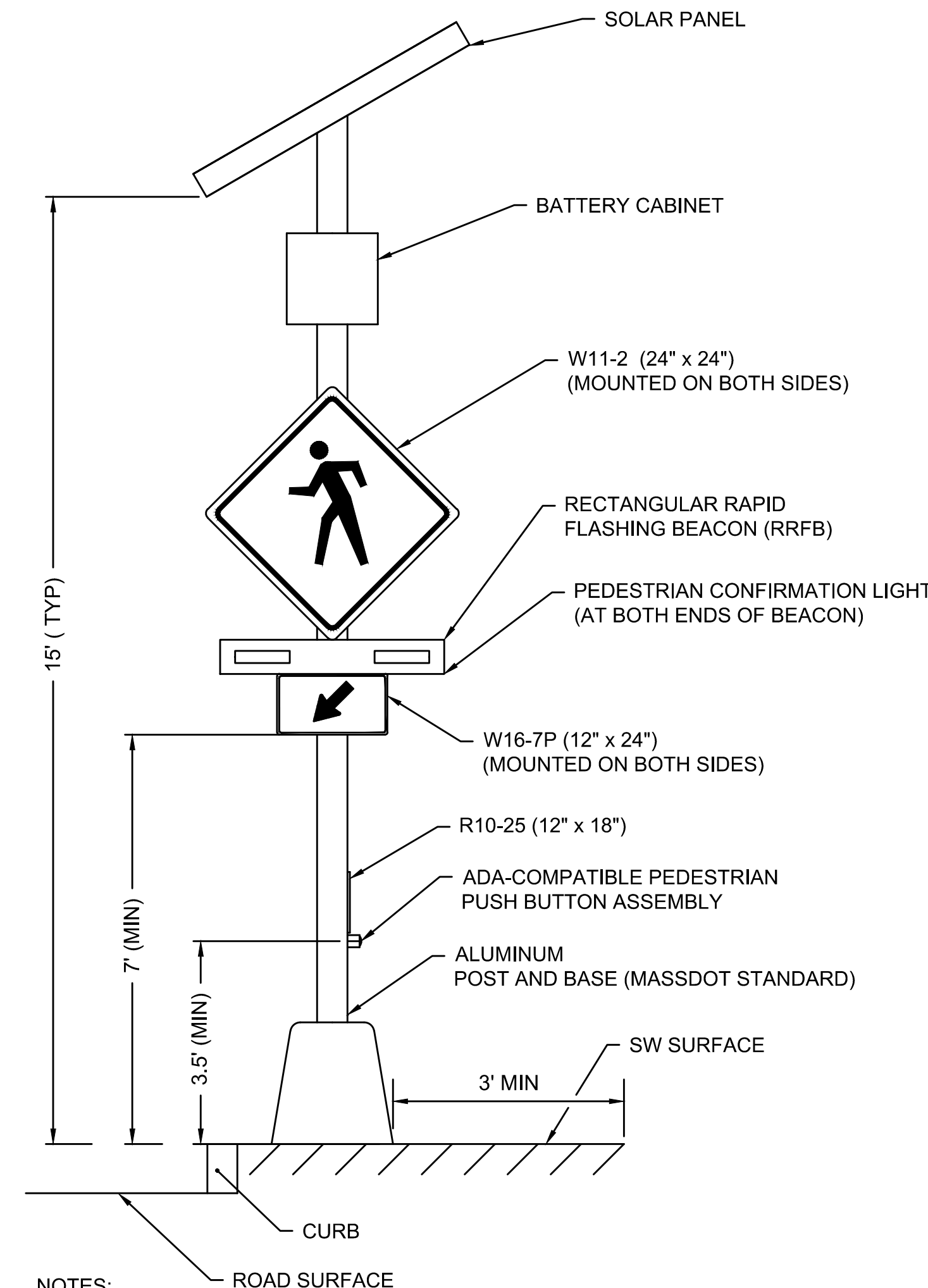

NOTES:

- OPERATION OF RRFB LED LIGHTS SHALL CONFORM TO FHWA INTERIM APPROVAL IA-21.
- EACH RRFB UNIT SHALL CONTAIN A CONFIRMATION LIGHT WITHIN THE BEACON AT EACH END THAT SHALL BE ILLUMINATED WHEN THE RRFB UNIT IS ACTIVATED.
- EACH RRFB UNIT SHALL BE SELF CONTAINED AND POWERED VIA A SOLAR PANEL.
- THE RRFB UNITS AT EACH CROSSWALK LOCATION SHALL COMMUNICATE WIRELESSLY WITH EACH OTHER. EACH CROSSWALK LOCATION SHALL OPERATE AS AN INDEPENDENT SYSTEM.
- UPON ACTIVATION OF A WAITING PEDESTRIAN, RRFB UNITS SHALL FLASH SIMULTANEOUSLY FOR A PERIOD OF 15 SECONDS, THEN STOP FLASHING.
- RRFB UNITS SHALL BE TAPCO, INC BRAND OR APPROVED EQUAL.
- THE CONTRACTOR SHALL PERFORM A SOLAR SURVEY TO CONFIRM LOCATION ADEQUACY.

RECTANGULAR RAPID FLASHING BEACON (RRFB)
NOT TO SCALE

DWY #	TYPE	MATERIAL	DRIVEWAY LOCATION		ROADWAY GUTTER SLOPE	TRANSITION LENGTH	
			STATION	OFFSET		LEFT SIDE	RIGHT SIDE
1	1	CONC	104+74	11' RT	3.85%	14'-0"	6'-6"
2	1	CONC	104+79	11' LT	3.85%	8'-0"	14'-0"
3	1	CONC	105+41	11' RT	4.86%	15'-0"	6'-6"
4	1	CONC	105+87	11' RT	2.86%	11'-0"	6'-6"
5	1	CONC	106+58	11' RT	2.93%	6'-6"	11'-0"
6	1	CONC	107+54	11' LT	0.42%	6'-6"	7'-8"
7	1	CONC	108+53	11' RT	0.42%	7'-8"	6'-6"
8	1	CONC	112+13	11' LT	1.20%	6'-6"	9'-0"
9	1	CONC	112+80	11' LT	1.41%	6'-6"	9'-0"
10	2	CONC	113+40	18'-4" LT	0.24%	6'-6"	7'-8"
11	2	CONC	114+25	15'-6" LT	0.24%	6'-6"	7'-8"
12	2	CONC	115+98	18'-0" LT	0.24%	6'-6"	7'-8"
13	2	CONC	117+70	14'-6" LT	0.93%	6'-6"	7'-8"
14	2	CONC	118+91	14'-6" LT	0.75%	6'-6"	7'-8"
15	1	CONC	119+97	11' LT	1.15%	6'-6"	9'-0"
16	1	CONC	120+19	11' RT	1.00%	6'-6"	-
17	1	HMA	120+75	11' RT	1.00%	7'-8"	6'-6"
18	1	HMA	121+18	11' LT	0.81%	6'-6"	7'-8"
19	1	HMA	121+74	11' RT	1.01%	9'-0"	6'-6"
20	1	HMA	121+84	11' LT	1.40%	9'-0"	6'-6"
21	1	HMA	122+73	11' RT	1.64%	9'-0"	6'-6"
22	1	HMA	123+12	11' RT	1.82%	3'-3" **	11'-0"
23	1	HMA	123+55	11' LT	1.82%	9'-0"	6'-6"
24	1	HMA	123+57	11' LT	2.08%	6'-6"	11'-0"
25	1	HMA	124+07	11' LT	2.08%	6'-6"	11'-0"
26	1	HMA	124+20	11' RT	2.04%	11'-0"	6'-6"
27	1	CONC	201+42	11' RT	6.67%	15'-0"	6'-6"
28	1	CONC	202+32	11' RT	4.35%	15'-0"	6'-6"
29	1	CONC	203+65	11' RT	5.56%	15'-0"	6'-6"
30	1	HMA	205+09	11' LT	2.04%	3'-3" **	11'-0"
31	1	HMA	205+85	11' LT	1.20%	-	9'-0"
32	1	HMA	205+99	11' RT	1.20%	-	6'-6"
33	1	HMA	206+14	11' RT	1.20%	9'-0"	-
34	1	HMA	206+37	11' LT	1.20%	6'-6"	9'-0"
35	1	HMA	207+42	11' RT	1.20%	9'-0"	6'-6"
36	1	HMA	207+51	11' LT	1.20%	6'-6"	-
37	1	HMA	207+78	11' LT	1.20%	-	9'-0"
38	1	HMA	208+55	11' RT	1.20%	9'-0"	6'-6"
39	1	HMA	209+79	11' LT	1.20%	9'-0"	6'-6"
40	1	CONC	300+54	12'-4" LT	1.20%	6'-6"	9'-0"
41	1	HMA	302+50	11' LT	5.50%	6'-6"	7'-8"
42	1	HMA	302+87	11' LT	5.36%	10'-2"	15'-0"

** 3 INCH REVEAL

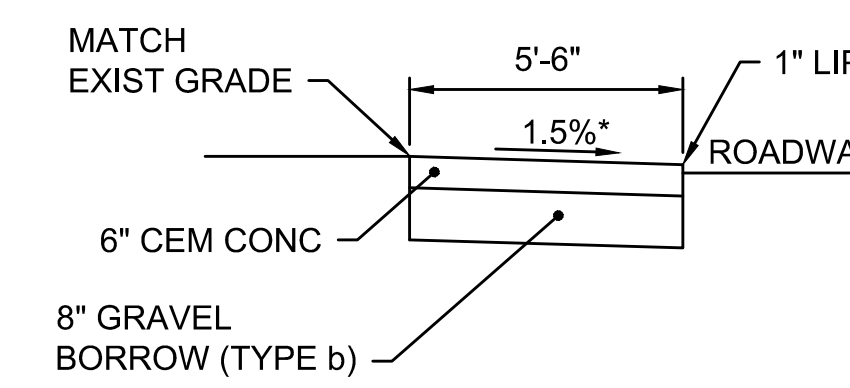
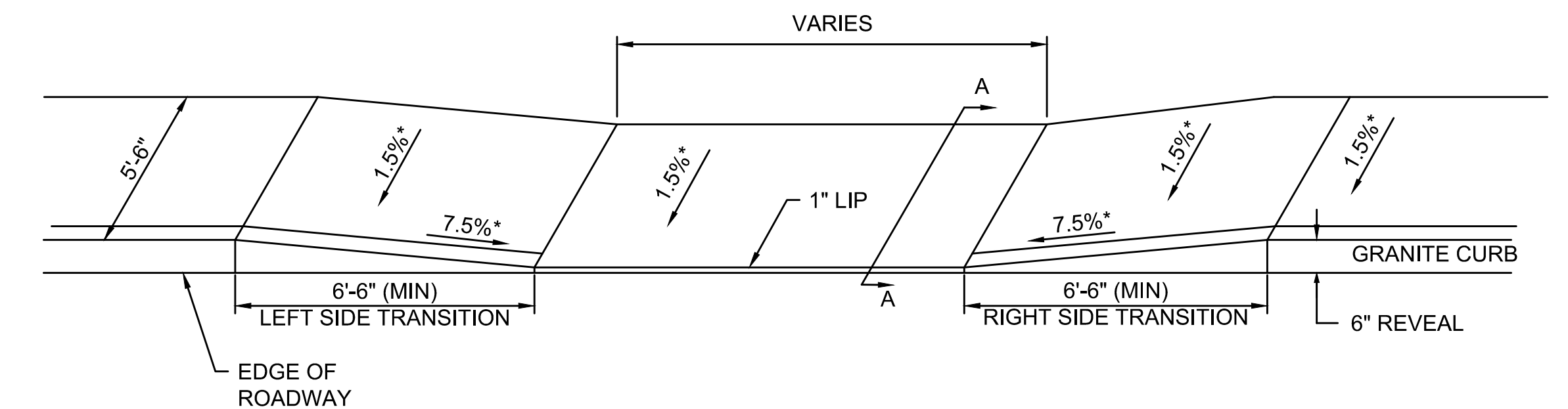

* TOLERANCE FOR CONSTRUCTION = ±0.5%

DRIVEWAY TYPE 1
NOT TO SCALE

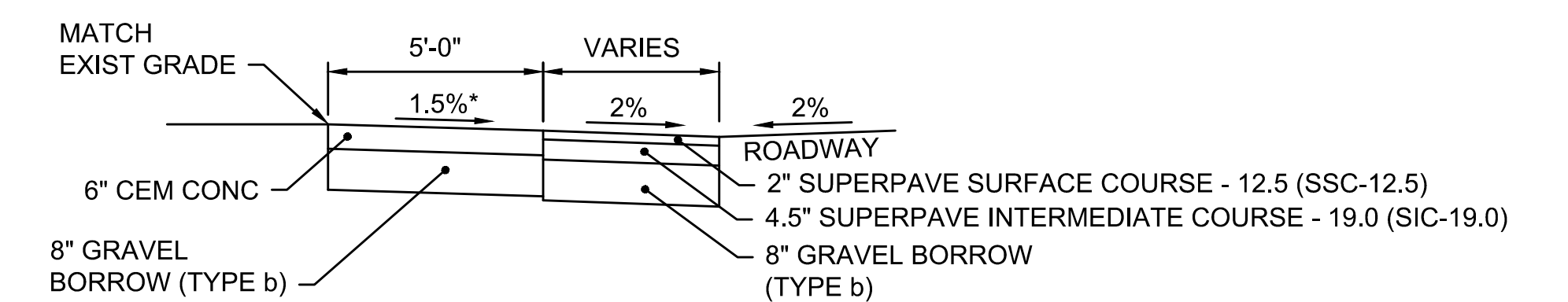
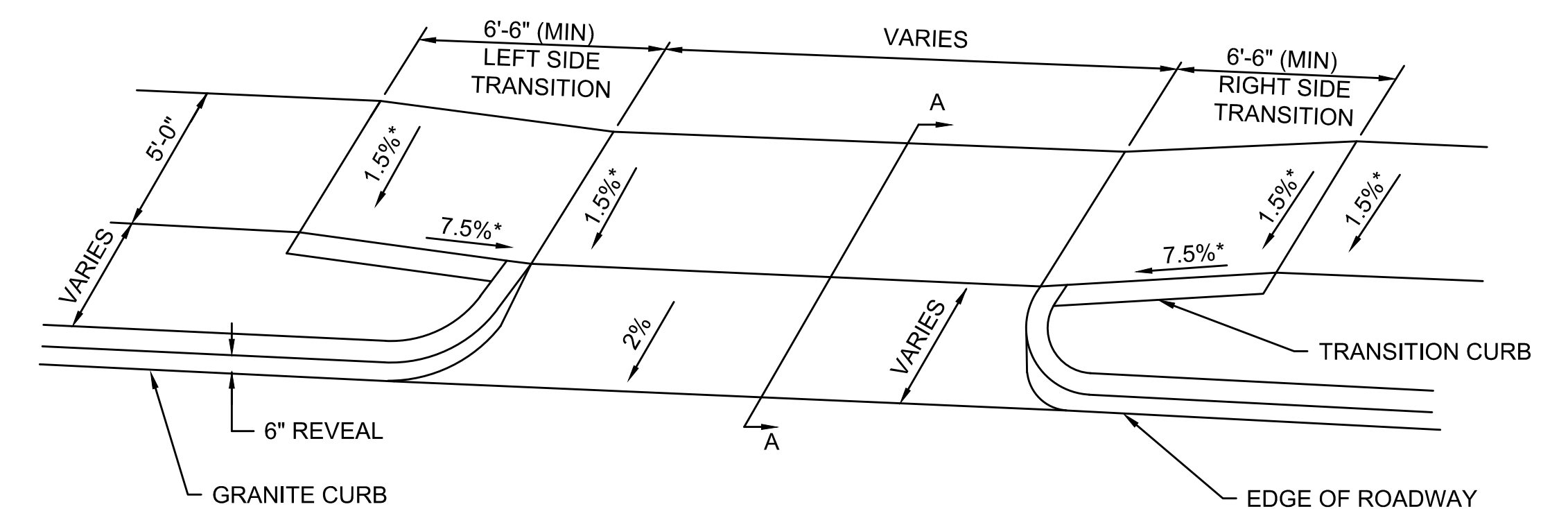

* TOLERANCE FOR CONSTRUCTION = ±0.5%

DRIVEWAY TYPE 2
NOT TO SCALE

SHEET NO.	TOTAL SHEETS
7	109

CONSTRUCTION NOTES AND DETAILS
SHEET 3 OF 10

REV #	DATE
△	11/28/18

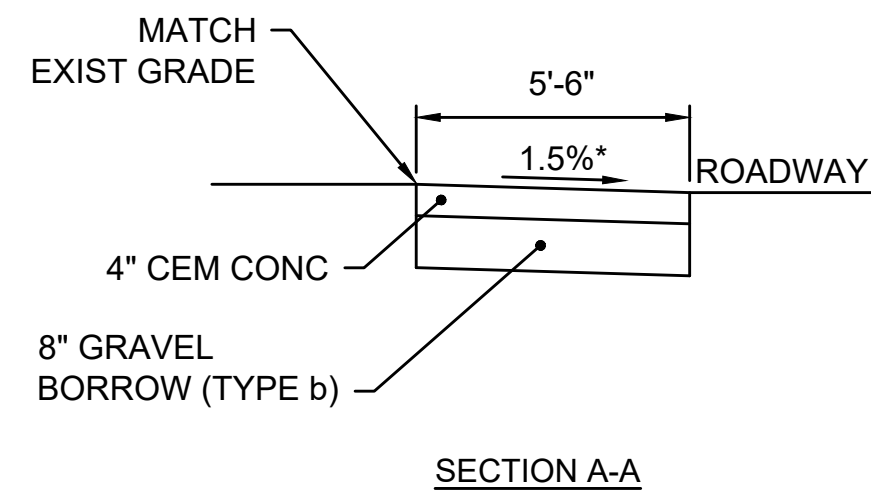
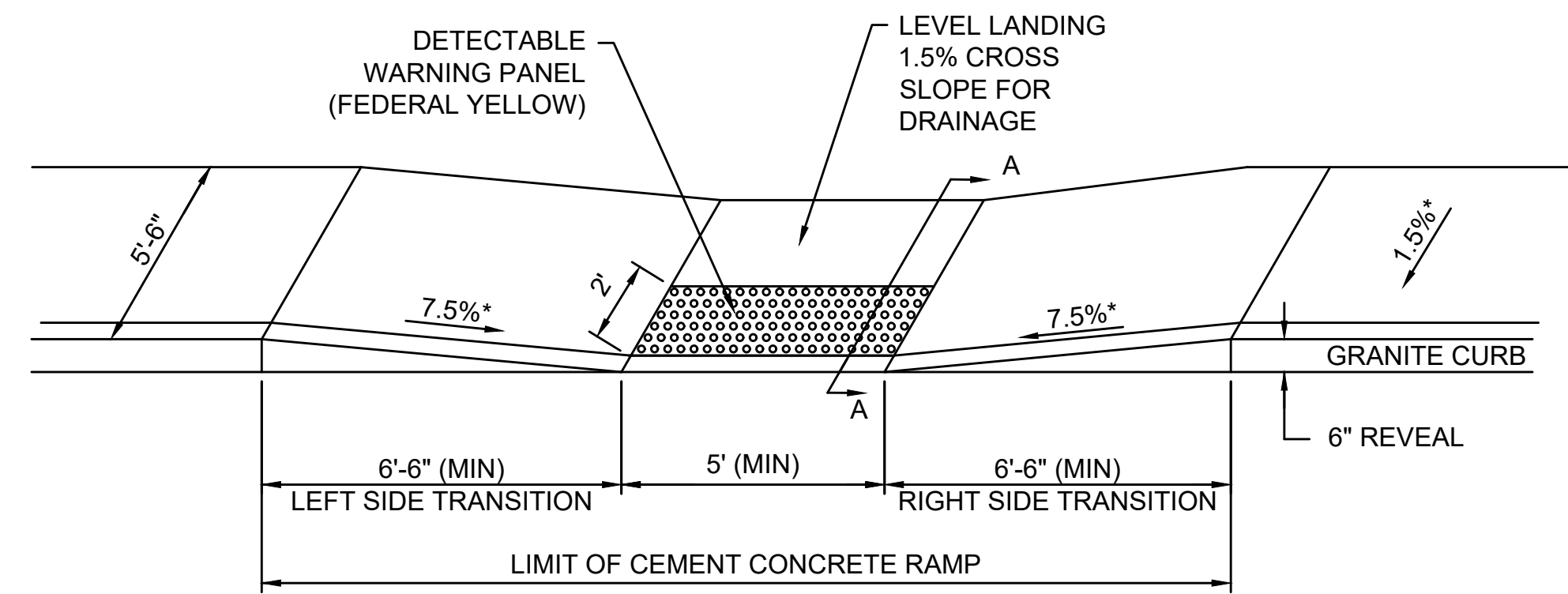

* TOLERANCE FOR CONSTRUCTION = ±0.5%

WCR #	WHEELCHAIR RAMP LOCATION		ROADWAY GUTTER SLOPE	TRANSITION LENGTH	
	STATION	OFFSET		LEFT SIDE	RIGHT SIDE
3	110+42	11 LT	1.00%	4'-4"	7'-8"
5	115+74	11 RT	0.45%	3'-6" **	--
8	124+78	11 RT	2.40%	5'-6" **	6'-6"
9	124+78	11 LT	2.59%	6'-6"	7'-8"
10	124+97	23 RT	3.80%	--	5'-0" **
11	125+41	23 RT	3.80%	7'-0"	--
13	200+14	15 RT	4.80%	15'-0"	6'-6"
16	204+71	11 LT	3.56%	3'-3" **	7'-6" **
17	204+71	11 RT	2.16%	15'-0"	6'-6"
20	300+18	22 LT	1.37%	9'-0"	6'-6"
21	300+27	18 RT	1.37%	--	7'-6"

** 3 INCH REVEAL

WHEELCHAIR RAMP TYPE 1
NOT TO SCALE

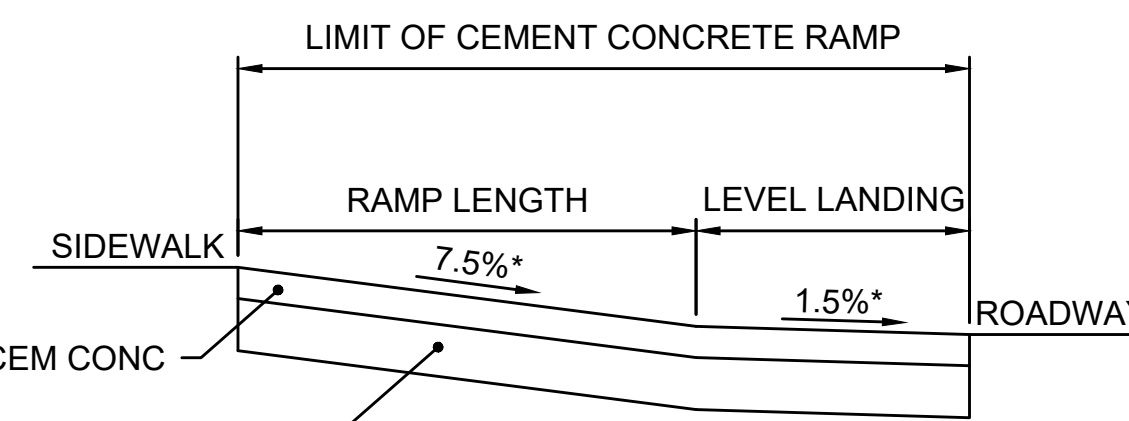
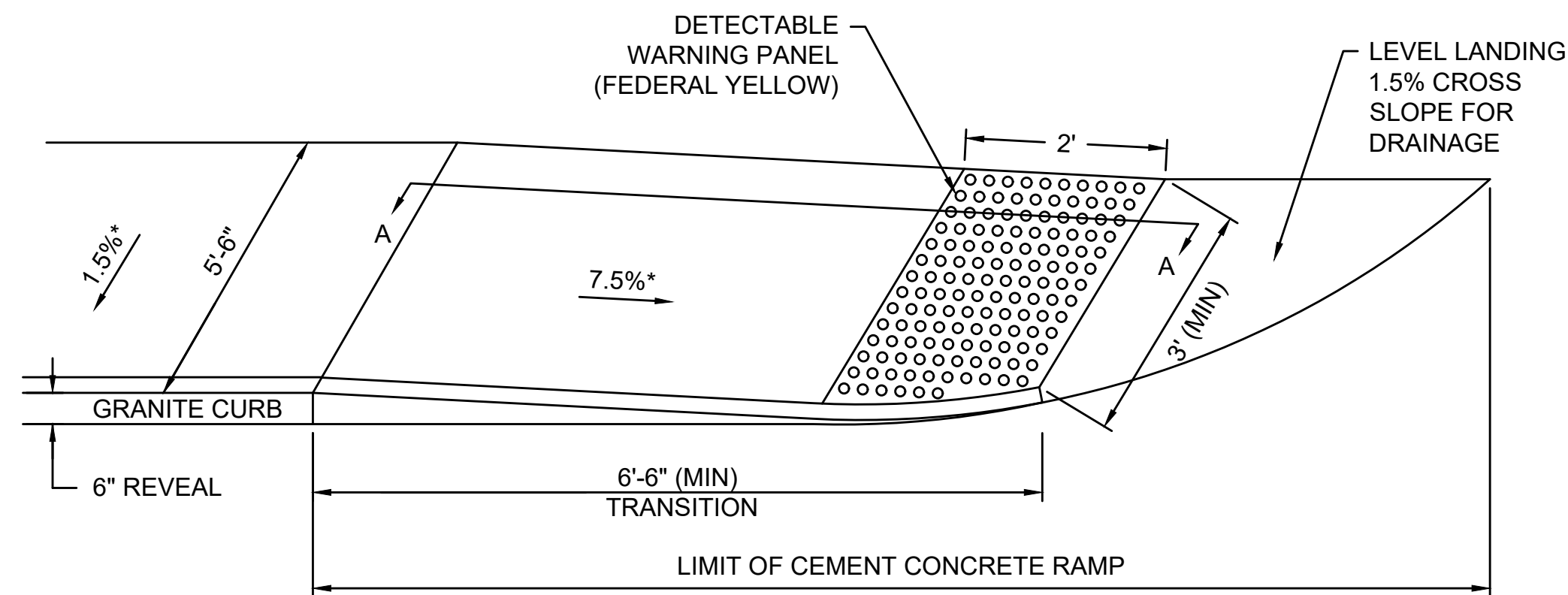

* TOLERANCE FOR CONSTRUCTION = ±0.5%

WCR #	WHEELCHAIR RAMP LOCATION		ROADWAY GUTTER SLOPE	TRANSITION LENGTH
	STATION	OFFSET		
1	107+36	11 RT	2.60%	11'-0"
2	107+79	11 RT	0.60%	7'-11"
4	115+74	10 LT	0.08%	7'-6"
6	116+25	20 RT	6.57%	6'-6"
7	116+60	20 RT	0.57%	7'-0"
12	125+56	66 LT	4.80%	15'-0"
14	200+47	12 RT	1.90%	9'-0"
15	200+77	13 RT	4.50%	15'-0"
18	210+53	12 RT	0.16%	8'-0"
19	211+02	12 RT	1.83%	9'-0"
24	305+76	11 LT	2.79%	6'-6"

WHEELCHAIR RAMP TYPE 2
NOT TO SCALE

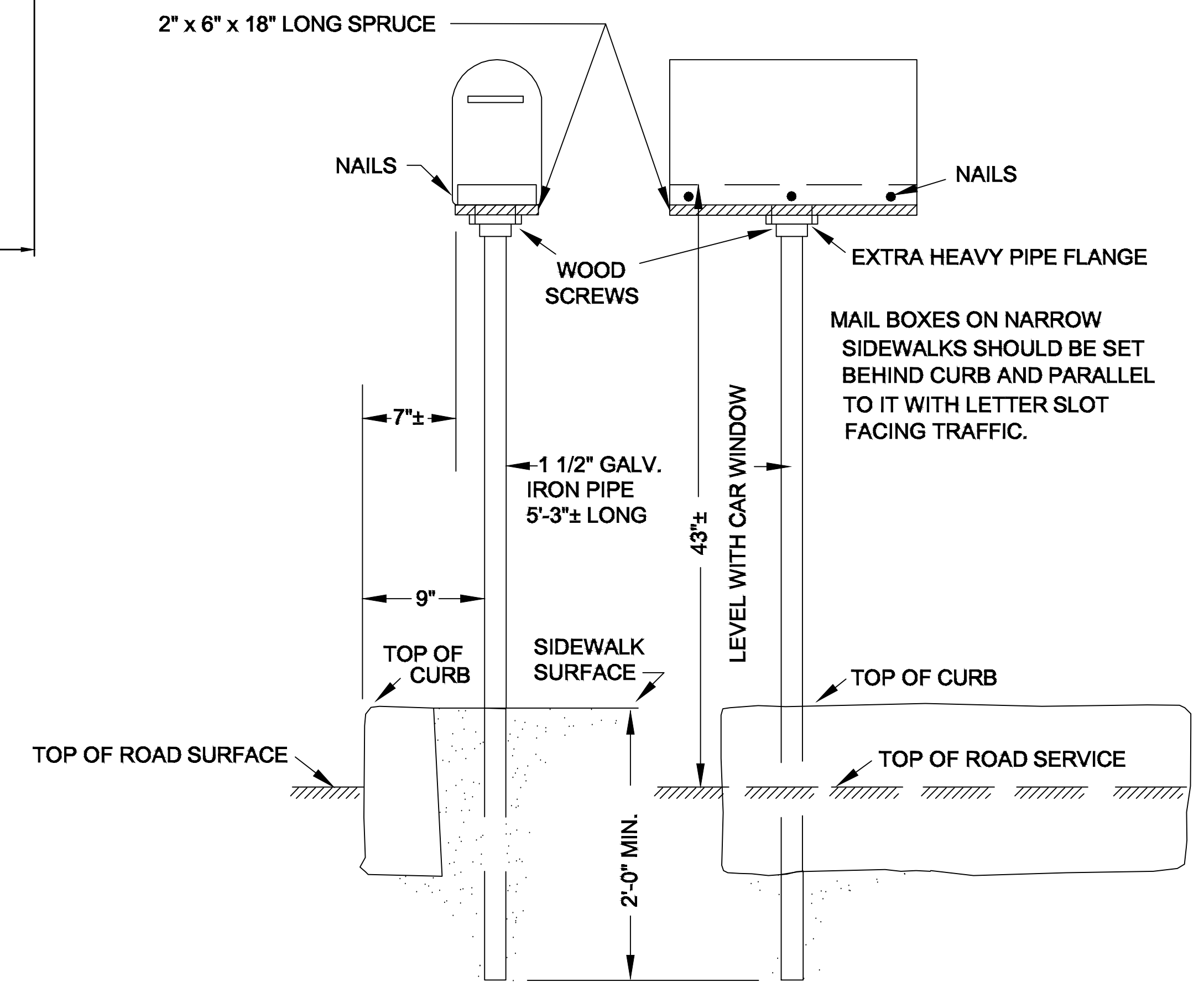

NOTES:

- LUMBER TO BE PLANED ON ALL FOUR SIDES TO FULL 2"x6" SIZE TO FIT BOTTOM OF MAIL BOXES.
- TO SET 1 1/2" GALVANIZED PIPE POST, USE DRIVING POINT OF SAME SIZE, THEN TAMP POST INTO PLACES SO AS TO BE PLUMB BOTH WAYS.
- ALL FITTINGS (PIPE FLANGES, PIPE, SCREWS, NAILS, ETC) ARE TO BE GALVANIZED.
- FOR ALL DESCRIPTIONS, MATERIALS, AND CONSTRUCTION METHODS SEE STANDARD SPECIFICATIONS.
- A 4"x4" PRESSURE TREATED WOOD POST MAY SUBSTITUTED FOR A PIPE POST.
- EXISTING MAILBOXES WILL BE RESET UNLESS RESIDENTS PROVIDE A DIFFERENT MAILBOX TO RESET, AND RESIDENTS WILL BE PROVIDED THEIR CHOICE OF PIPE OR LUMBER POST.

RURAL MAILBOX
NOT TO SCALE

SHEET NO.	TOTAL SHEETS
8	109

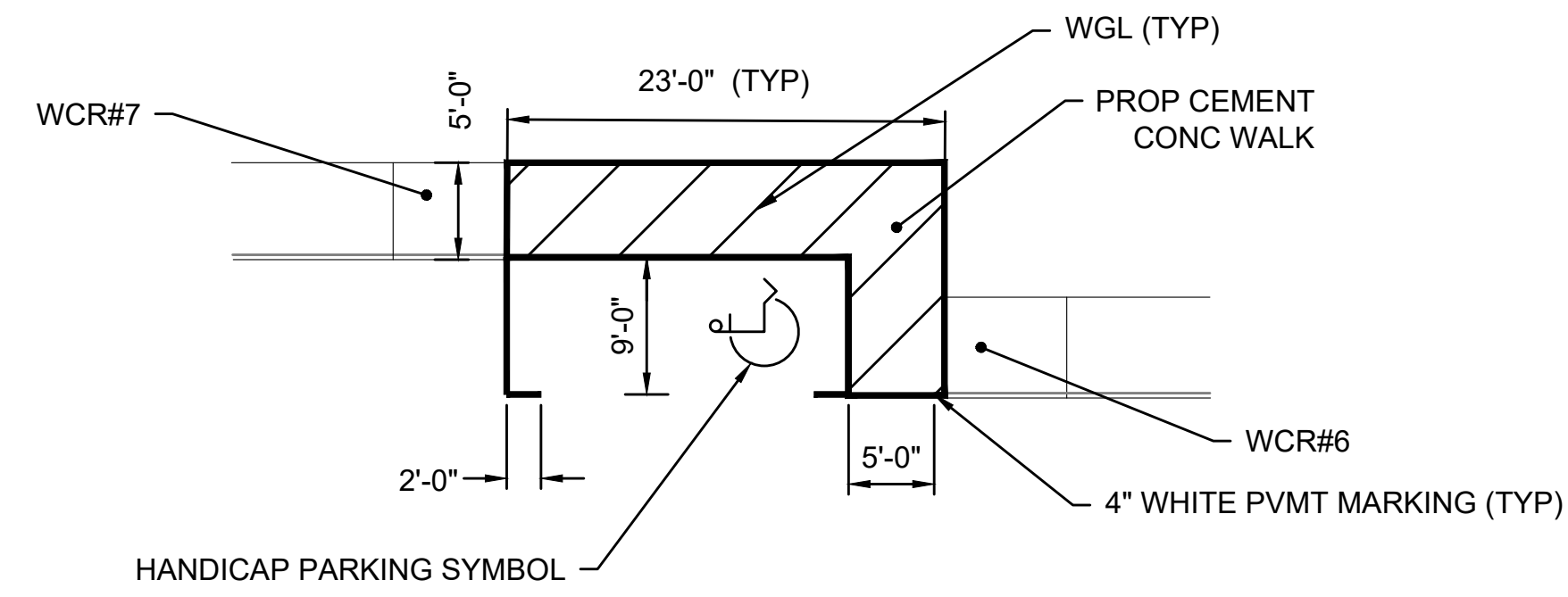

* TOLERANCE FOR CONSTRUCTION = ±0.5%

ON-STREET HANDICAP PARKING DETAIL
NOT TO SCALE

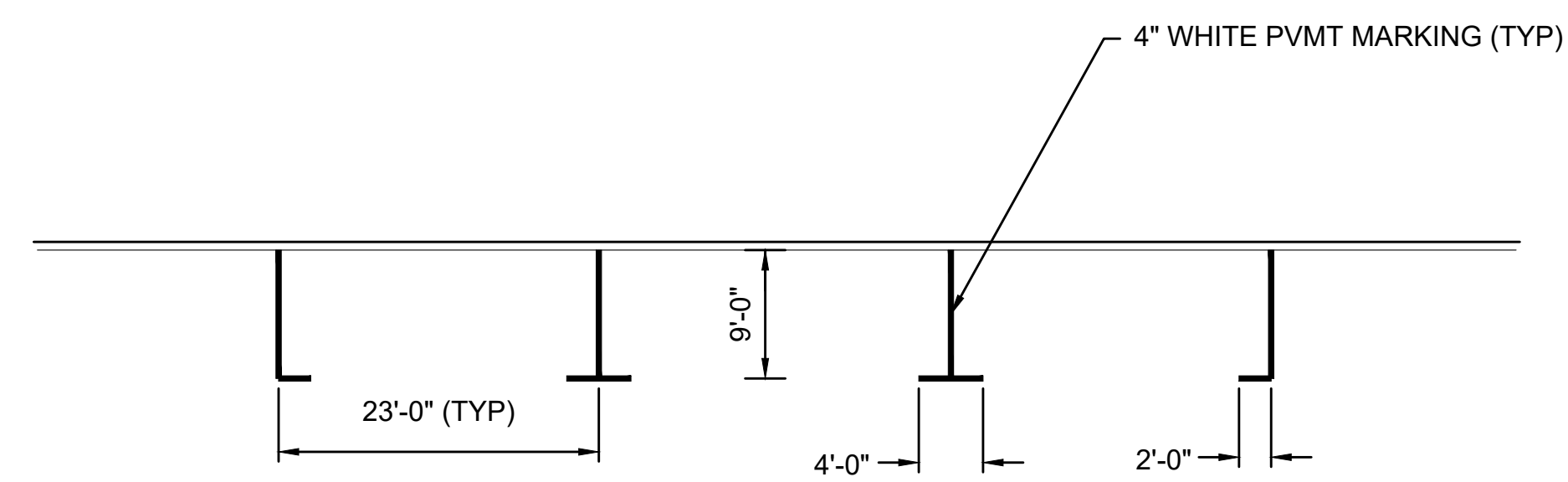

ON-STREET PARKING DETAIL
NOT TO SCALE

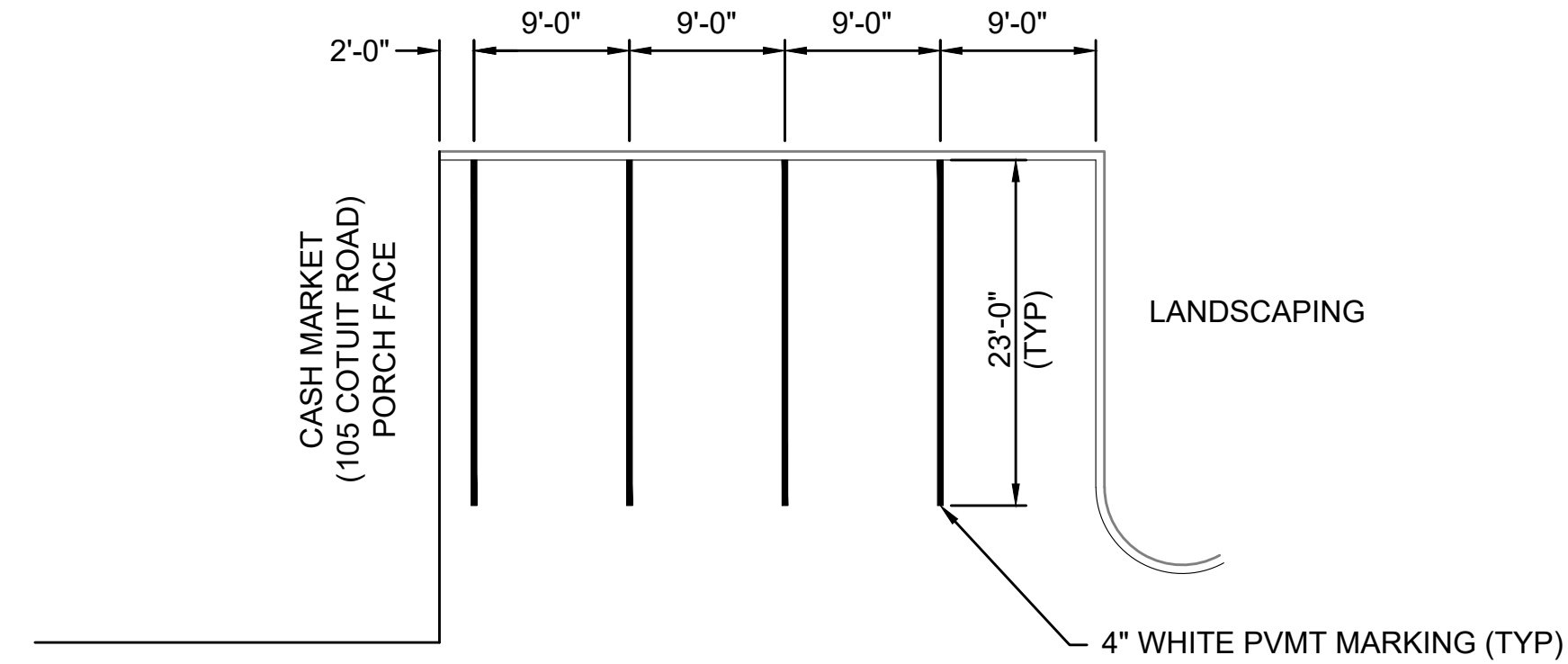

CASH MARKET (105 ROUTE 149) PARKING AREA DETAIL
NOT TO SCALE

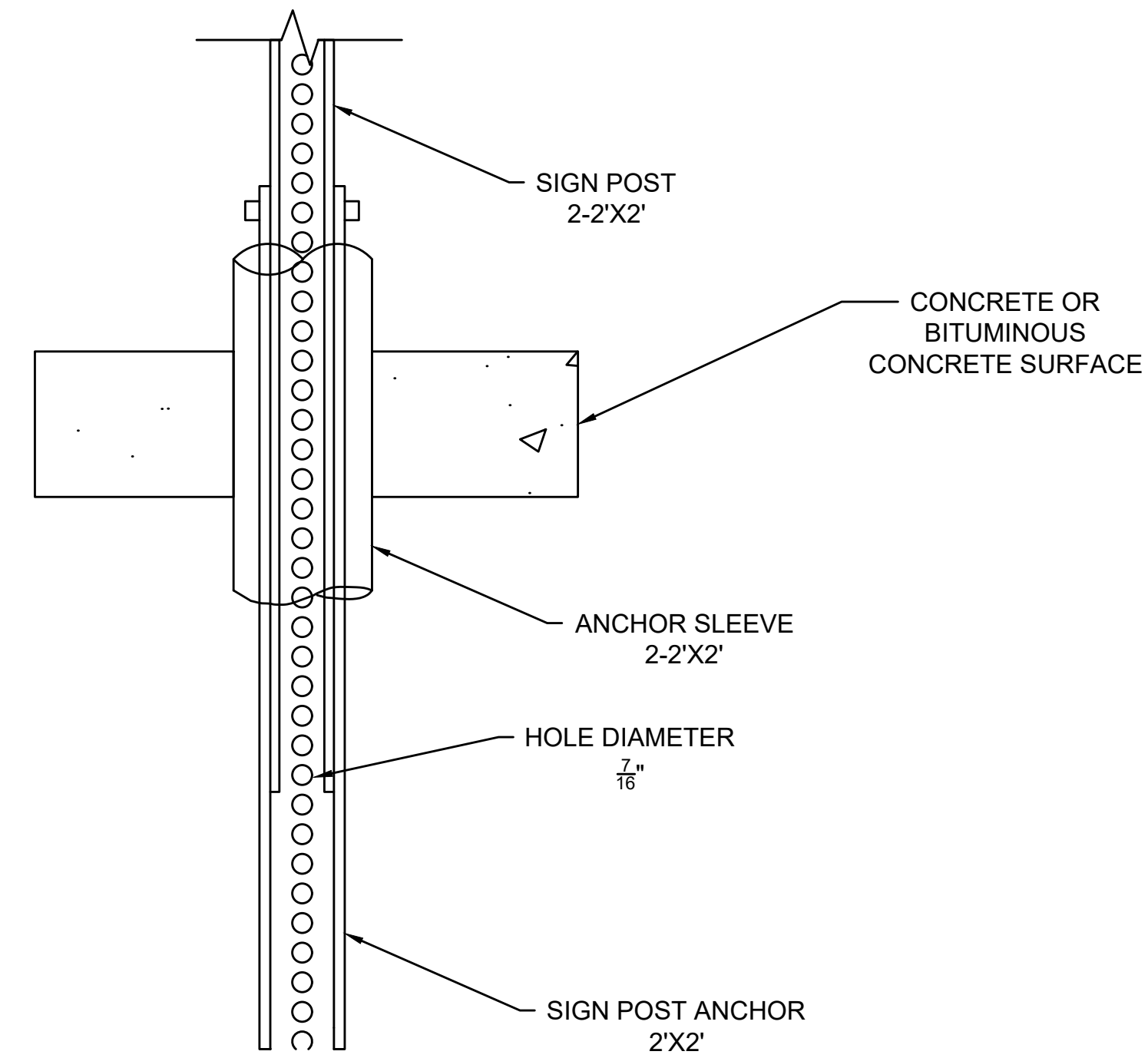

P-5 TELESCOPIC TUBULAR POST
NOT TO SCALE

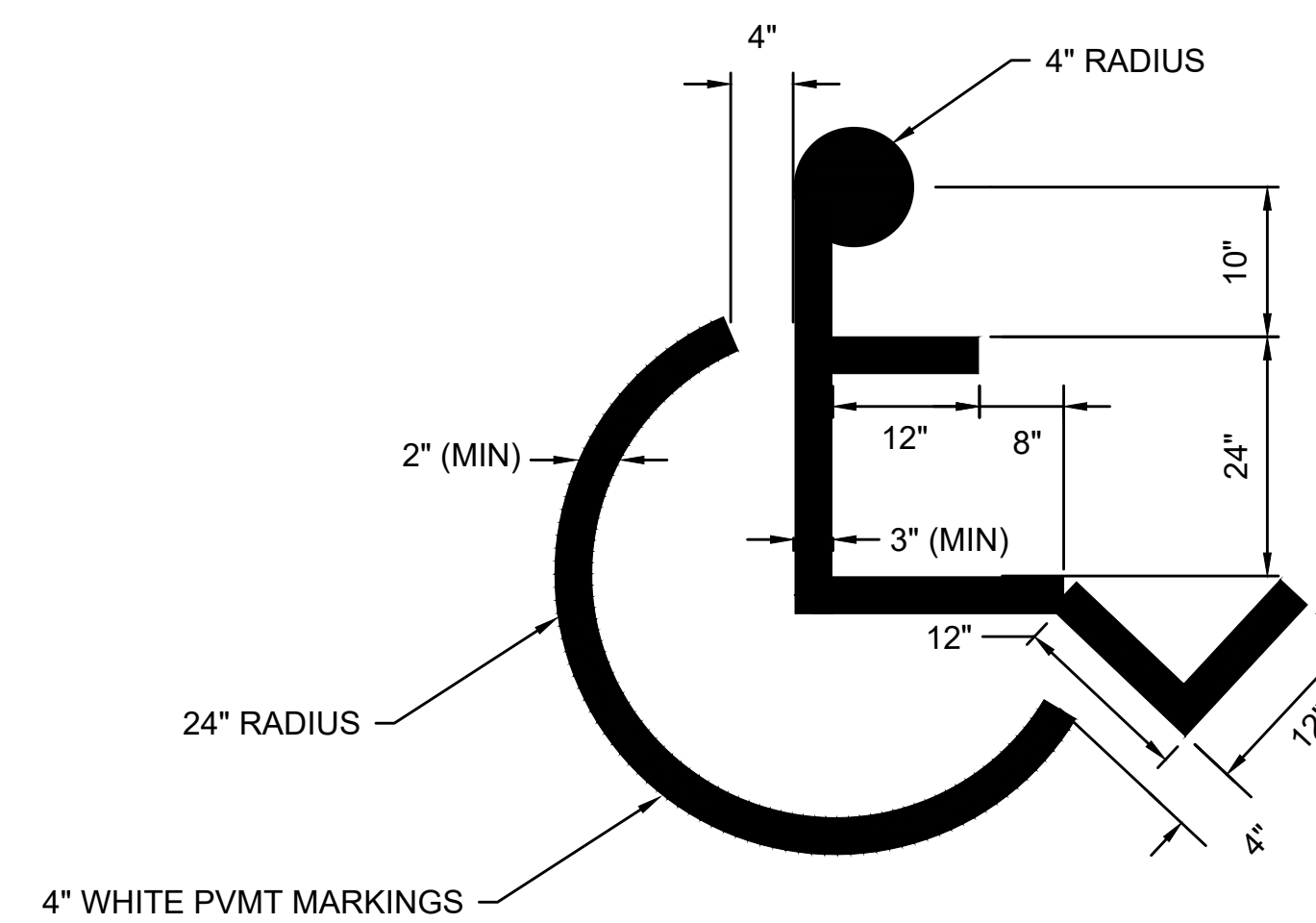

- NOTES:
1. SYMBOL SHALL BE CENTERED IN THE PARKING STALL.
2. PAVEMENT MARKINGS TO BE INSTALLED IN LOCATIONS SHOWN ON THE PLANS.

HANDICAP PARKING SYMBOL
NOT TO SCALE

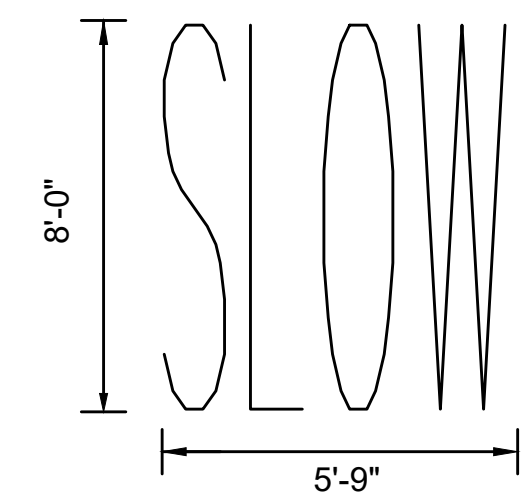

"SLOW" PAVEMENT MARKING
NOT TO SCALE

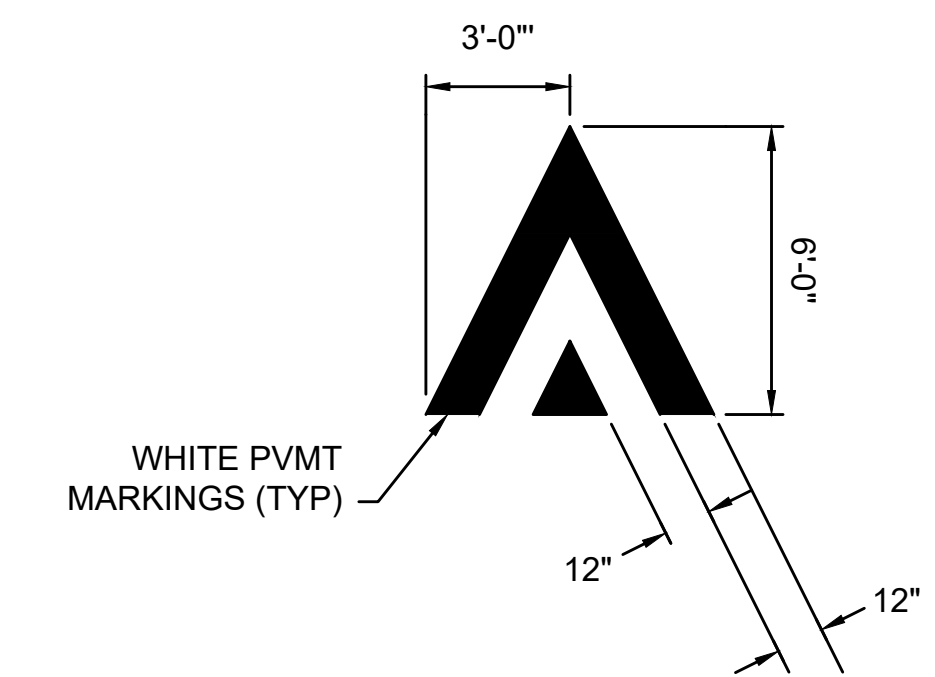

RAISED CROSSING PAVEMENT MARKING
NOT TO SCALE

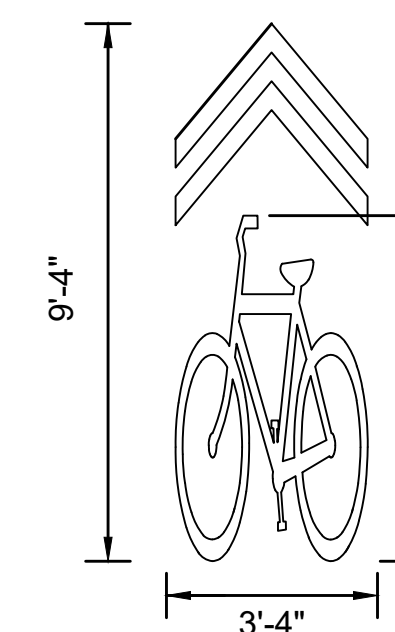

SHARROW SYMBOL
NOT TO SCALE

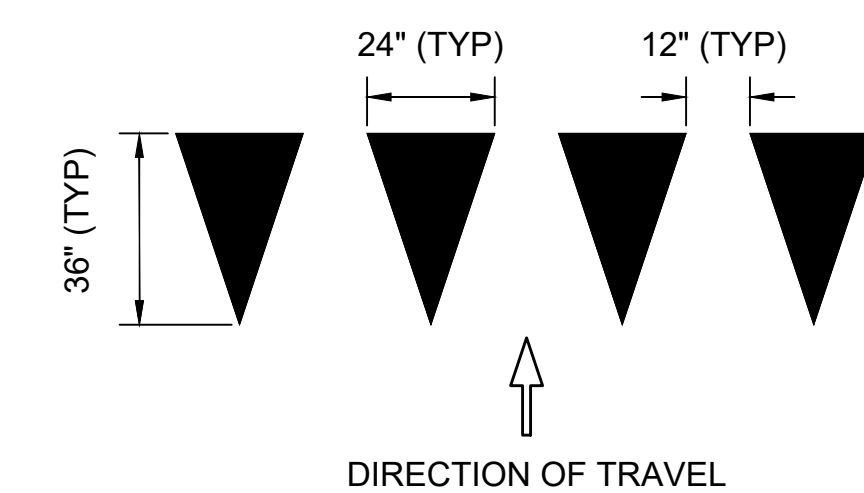

YIELD LINE
NOT TO SCALE

SURVEY NOTES

1. THE TOPOGRAPHY AND EXISTING CONDITIONS DEPICTED HEREON WERE OBTAINED FROM AN INSTRUMENT SURVEY CONDUCTED ON THE GROUND BY THE HORSLEY WITTEN GROUP, INC.
2. THIS PLAN DOES NOT SHOW ANY RECORDED OR UNWRITTEN EASEMENTS WHICH MAY EXIST, HOWEVER, THIS DOES NOT CONSTITUTE A GUARANTEE THAT NO SUCH EASEMENTS EXIST.
3. THE ELEVATIONS DEPICTED HEREON WERE BASED ON THE NORTH AMERICAN VERTICAL DATUM OF 1988.
4. ALL ABUTTING PROPERTY AND BOUNDARY LINES DEPICTED ARE APPROXIMATE ONLY.
5. THE RIGHT-OF-WAY LINES SHOWN HEREON ARE BASED ON A COMPILATION OF RECORD PLANS AND DEEDS OBTAINED FROM THE PUBLIC RECORDS.
6. EXISTING CONTOUR INTERVALS ARE EQUAL TO ONE FOOT.
7. THE ACCURACY OF MEASURED PIPE INVERTS AND PIPE SIZES IS SUBJECT TO FIELD CONDITIONS, THE ABILITY TO MAKE VISUAL OBSERVATIONS, DIRECT ACCESS TO THE VARIOUS ELEMENTS AND OTHER CONDITIONS.

GENERAL CONSTRUCTION NOTES

1. ALL WORK TO COMPLETE THIS PROJECT AS INDICATED ON THE DRAWINGS AND IN THE SPECIFICATIONS IS THE SOLE RESPONSIBILITY OF THE CONTRACTOR.
2. MAKE ALL NECESSARY CONSTRUCTION NOTIFICATIONS AND APPLY FOR AND OBTAIN ALL NECESSARY CONSTRUCTION PERMITS, PAY ALL FEES INCLUDING POLICE DETAILS AND POST ALL BONDS, IF NECESSARY, ASSOCIATED WITH THE SAME, AND COORDINATE WITH THE OWNER AND THE ENGINEER.
3. ALL EXISTING CONDITIONS SHOWN ARE APPROXIMATE AND ARE BASED ON THE BEST INFORMATION AVAILABLE. PRIOR TO THE START OF CONSTRUCTION VERIFY THAT THE PROPOSED IMPROVEMENTS SHOWN ON THE PLANS DO NOT CONFLICT WITH ANY EXISTING UTILITIES AND STRUCTURES. IF ANY CONFLICTS ARE DISCOVERED, NOTIFY THE OWNER AND THE ENGINEER PRIOR TO INSTALLING ANY PORTION OF THE SITE WORK WHICH WOULD BE AFFECTED.
4. THE LOCATION AND/OR ELEVATION OF EXISTING UTILITIES AND STRUCTURES AS INDICATED ON THE DRAWINGS ARE BASED ON RECORDS OF VARIOUS UTILITY COMPANIES, AND WHEREVER POSSIBLE, MEASUREMENTS TAKEN IN THE FIELD. THIS INFORMATION IS NOT TO BE RELIED UPON AS BEING EXACT OR COMPLETE. VERIFY THE LOCATION OF ALL UNDERGROUND UTILITIES AND STRUCTURES IN THE FIELD PRIOR TO THE START OF CONSTRUCTION. CONTACT THE APPROPRIATE UTILITY COMPANY, ANY GOVERNING PERMITTING AUTHORITY IN THE TOWN, AND "DIGSAFE" (1-888-344-7233) AT LEAST 72 HOURS PRIOR TO ANY EXCAVATION WORK IN PREVIOUSLY UNALTERED AREAS TO REQUEST EXACT FIELD LOCATION OF UTILITIES. THE CONTRACTOR MUST RESOLVE CONFLICTS BETWEEN THE PROPOSED UTILITIES AND FIELD-LOCATED UTILITIES AND REPORT ANY DISCREPANCIES TO THE ENGINEER IMMEDIATELY. THE ENGINEER ASSUMES NO RESPONSIBILITY FOR DAMAGES INCURRED AS A RESULT OF UTILITIES OMITTED, INCOMPLETELY SHOWN, OR INCORRECTLY SHOWN. THE CONTRACTOR MUST MAINTAIN ACCURATE RECORDS OF THE LOCATION AND ELEVATION OF ALL WORK INSTALLED AND EXISTING UTILITIES FOUND DURING CONSTRUCTION FOR THE PREPARATION OF THE AS-BUILT PLAN.
5. COORDINATE AND MAKE ALL CONNECTION ARRANGEMENTS WITH UTILITY COMPANIES, AS REQUIRED.
6. THE CONTRACTOR MUST MAINTAIN ALL EXISTING UTILITIES IN WORKING ORDER AND FREE FROM DAMAGE DURING THE CONSTRUCTION. REPAIR ANY DAMAGE TO EXISTING UTILITY LINES OR STRUCTURES INCURRED DURING CONSTRUCTION OPERATIONS AT NO COST TO THE OWNER. THE CONTRACTOR IS RESPONSIBLE FOR ALL COST RELATED TO THE REPAIR OF UTILITIES. EXCAVATION REQUIRED WITHIN THE PROXIMITY OF EXISTING UTILITY LINES MUST BE DONE BY HAND.
7. THE CONTRACTOR SHALL BE RESPONSIBLE FOR ADJUSTING OR REMODELING ALL DRAINAGE, WATER, SEWER, OR GAS STRUCTURES WITHIN THE PROJECT LIMITS AS DIRECTED BY THE TOWN.
8. THE CONTRACTOR SHALL NOT STORE ANY APPARATUS, MATERIALS, SUPPLIES, OR EQUIPMENT ON DRAINAGE STRUCTURES, PRIVATE PROPERTY OR WITHIN 100 FEET OF WETLANDS, UNLESS INDICATED ON THE DRAWINGS.
9. THE CONTRACTOR SHALL PERFORM TEST PITS AT LOCATIONS WHERE DIRECTED BY THE TOWN AND OR ENGINEER.
10. COORDINATE ALL TRENCHING WORK WITHIN ROADWAYS WITH THE PROPER LOCAL & STATE AGENCY. THE CONTRACTOR IS RESPONSIBLE FOR ALL TRENCH SAFETY INCLUDING ANY LOCAL AND/OR STATE PERMITS REQUIRED FOR THE TRENCH WORK. IF THIS WORK IS REQUIRED TO OCCUR OUTSIDE THE AGREED UPON HOURS OF OPERATION FOR THE FACILITY, THE CONTRACTOR MUST PLAN ACCORDINGLY.
11. INSTALL ALL UTILITY TRENCH WORK PRIOR TO INSTALLING NEW PAVEMENT AS INDICATED ON THE DRAWINGS.
12. ALL STRUCTURES AND PIPELINES LOCATED ADJACENT TO THE TRENCH EXCAVATION SHALL BE PROTECTED AND FIRMLY SUPPORTED BY THE CONTRACTOR UNTIL THE TRENCH IS BACKFILLED. INJURY TO ANY SUCH STRUCTURE CAUSED BY, OR RESULTING FROM, THE CONTRACTOR'S OPERATIONS SHALL BE REPAIRED AT THE CONTRACTOR'S EXPENSE. ALL UTILITIES REQUIRING REPAIR, RELOCATION OR ADJUSTMENT AS A RESULT OF THE PROJECT SHALL BE COORDINATED THROUGH THE RESPECTIVE UTILITY AND THE TOWN.
13. IN THOSE INSTANCES WHERE POWER OR TELEPHONE POLE SUPPORT IS REQUIRED, THE CONTRACTOR SHALL PROVIDE A MINIMUM 48-HOUR NOTIFICATION TO THE RESPECTIVE UTILITY COMPANY. NO ADDITIONAL PAYMENT WILL BE PROVIDED FOR TEMPORARY BRACINGS OF UTILITIES.
14. THE CONTRACTOR IS TO TAKE SPECIAL CARE NOT TO DAMAGE TREES, BUSHES, PLANTS, FLOWERS, STONEWALLS, FENCES, ETC. WITHIN THE CONSTRUCTION AREA UNLESS THEY ARE NOTED TO BE REMOVED. CONTRACTOR SHALL REPLACE AT NO COST TO OWNER, ALL DAMAGED ITEMS.
15. CONTRACTOR SHALL REMOVE AND REPLACE, OR REPAIR, ALL CURBS, SIDEWALKS, PAVEMENT AND OTHER ITEMS DAMAGED BY HIS CONSTRUCTION ACTIVITIES TO AT LEAST THEIR ORIGINAL CONDITION, AND TO THE SATISFACTION OF THE TOWN AND ENGINEER.
16. THE CONTRACTOR SHALL BE REQUIRED TO PROVIDE A TELEPHONE NUMBER WHERE THE CONTRACTOR CAN BE REACHED 24 HOURS A DAY, 7 DAYS A WEEK.
17. THE LOCATION AND LIMITS OF ALL ON-SITE WORK AND STORAGE AREAS SHALL BE REVIEWED WITH THE TOWN AND ACCEPTABLE TO THE TOWN. THE CONTRACTOR SHALL LIMIT ACTIVITIES TO THESE AREAS.
18. THE CONTRACTOR SHALL BE REQUIRED TO TEMPORARILY PAVE ALL DISTURBED TRAVEL WAYS, SIDEWALKS & DRIVEWAYS NOT UNDER CONSTRUCTION OR IF LEFT DURING NON-WORKING HOURS AND AS REQUIRED BY THE TOWN.
19. IMPORT ONLY CLEAN MATERIAL FROM AN EXISTING OR FUTURE SITE AS DEFINED BY THE MASSACHUSETTS CONTINGENCY PLAN 310 CMR 40.0000 WILL NOT BE ACCEPTED.
20. IT IS THE RESPONSIBILITY OF THE CONTRACTOR TO ESTABLISH AND MAINTAIN ALL CONTROL POINTS AND BENCHMARKS DURING CONSTRUCTION INCLUDING BENCHMARK LOCATIONS AND ELEVATIONS AT CRITICAL AREAS. COORDINATE WITH THE ENGINEER THE LOCATION OF ALL CONTROL POINTS AND BENCHMARKS.
21. SITE LAYOUT SURVEY REQUIRED FOR CONSTRUCTION MUST BE PROVIDED BY THE CONTRACTOR AND PERFORMED BY A MASSACHUSETTS REGISTERED PROFESSIONAL LAND SURVEYOR. THE CONTRACTOR IS RESPONSIBLE FOR COORDINATING WITH THE SURVEYOR FOR ALL SITE SURVEY WORK.
22. MAINTAIN ALL GRADE STAKES SET BY THE SURVEYOR. GRADE STAKES ARE TO REMAIN UNTIL A FINAL INSPECTION OF THE ITEM HAS BEEN COMPLETED BY THE ENGINEER. RE-STAKING OF PREVIOUSLY SURVEYED SITE FEATURES IS THE RESPONSIBILITY (INCLUDING COST) OF THE CONTRACTOR.
23. PROVIDE ALL CONSTRUCTION SERVICE IN ACCORDANCE WITH APPLICABLE LAWS AND REGULATIONS REGARDING NOISE, VIBRATION, DUST, SEDIMENTATION CONTAINMENT, AND TRENCH WORK.
24. COLLECT SOLID WASTES AND STORE IN A SECURED DUMPSTER. THE DUMPSTER MUST MEET ALL LOCAL AND STATE SOLID WASTE MANAGEMENT REGULATIONS.
25. REGULARLY INSPECT THE PERIMETER OF THE PROPERTY TO CLEAN UP AND REMOVE LOOSE CONSTRUCTION DEBRIS BEFORE IT LEAVES THE SITE. PROMPTLY REMOVE ALL DEMOLITION DEBRIS FROM THE SITE TO AN APPROVED DUMP SITE.
26. ALL TRUCKS LEAVING THE SITE MUST BE COVERED.
27. DO NOT WASH ANY CONCRETE TRUCKS ON-SITE. REMOVE BY HAND ANY CEMENT OR CONCRETE DEBRIS LEFT IN THE DISTURBED AREA.
28. BURIAL OF ANY STUMPS, SOLID DEBRIS, AND/OR STONES/BOULDERS ON-SITE IS PROHIBITED.
29. IMMEDIATELY CONTACT AND COORDINATE WITH THE ENGINEER AND OWNER IF ANY DEVIATION OR ALTERATION OF THE WORK PROPOSED ON THESE DRAWINGS IS REQUIRED.
30. AT THE END OF CONSTRUCTION REMOVE ALL CONSTRUCTION DEBRIS AND SURPLUS MATERIALS FROM THE SITE PERFORM A THOROUGH INSPECTION OF THE WORK PERIMETER. COLLECT AND REMOVE ALL MATERIALS AND BLOWN OR WATER CARRIED DEBRIS FROM THE SITE.

EROSION & SEDIMENT CONTROL (ESC) NOTES

1. PRIOR TO THE START OF CONSTRUCTION A NOTICE OF INTENT (NOI) MUST BE FILED WITH NPDES. REFER TO THE STORMWATER AND POLLUTION PREVENTION PLAN (SWPPP) REGARDING ALL EROSION CONTROL MEASURES. MAINTAIN A WORKING COPY OF THE SWPPP ON-SITE AT ALL TIMES. FOLLOW THE SWPPP PROTOCOL FOR SITE MAINTENANCE, INSPECTIONS AND PROPER DOCUMENTATION UNTIL THE SITE HAS BEEN ACCEPTED BY THE OWNER. AT THE COMPLETION OF THE PROJECT THE CONTRACTOR OR OWNER MUST FILE A NOTICE OF TERMINATION WITH NPDES. IN ACCORDANCE WITH NPDES REGULATIONS, THE COMPLETED SWPPP MUST INCLUDE ALL OF THE SITE EROSION CONTROL DOCUMENTATION, WEEKLY EROSION INSPECTION REPORTS COMPLETED BY THE DESIGNATED SITE PERSONNEL, AND ANY OTHER PERTINENT SITE DOCUMENTATION MUST BE RETAINED FOR A MINIMUM OF 3 YEARS FROM THE DATE OF TERMINATION.
2. DESIGNATE ON-SITE PERSONNEL RESPONSIBLE FOR THE DAILY INSPECTION AND MAINTENANCE OF ALL EROSION AND SEDIMENT CONTROL MEASURES AND IMPLEMENTATION OF ALL NECESSARY MEASURES TO CONTROL EROSION AND PREVENT SEDIMENT FROM LEAVING THE SITE.
3. INSTALL ALL EROSION AND SEDIMENT CONTROL (ESC) MEASURES AS INDICATED ON DRAWINGS IN CONSULTATION WITH THE CONSERVATION AGENT, AND ENGINEER BEFORE ANY CONSTRUCTION ACTIVITIES BEGIN. INSPECT, MAINTAIN, REPAIR AND REPLACE EROSION CONTROL MEASURES, AS NECESSARY, DURING THE ENTIRE CONSTRUCTION PERIOD OF THE PROJECT. THE SITE PERIMETER EROSION CONTROLS ARE THE DESIGNATED LIMIT OF WORK. INFORM ALL PERSONNEL WORKING ON THE PROJECT SITE THAT NO CONSTRUCTION ACTIVITY IS TO OCCUR BEYOND THE LIMIT OF WORK AT ANY TIME THROUGHOUT THE CONSTRUCTION PERIOD.
4. PROTECT THE ADJACENT RESOURCE AREA FROM SEDIMENTATION DURING PROJECT CONSTRUCTION UNTIL ACCEPTANCE BY THE OWNER & IN CONFORMANCE WITH THE ORDER OF CONDITIONS.
5. KEEP THE LIMIT OF CLEARING, GRADING AND DISTURBANCES TO A MINIMUM WITHIN THE PROPOSED AREA OF CONSTRUCTION. PHASE THE SITE WORK IN A MANNER TO MINIMIZE AREAS OF EXPOSED SOIL. IF TREES ARE TO BE CUT, CLEAR AND GRUB ONLY THOSE AREAS WHICH ARE ACTIVELY UNDER CONSTRUCTION. PROPERLY INSTALL THE SEDIMENTATION CONTROLS PRIOR TO BEGINNING ANY LAND CLEARING ACTIVITY AND/OR OTHER CONSTRUCTION RELATED WORK.
6. MONITOR LOCAL WEATHER REPORTS DURING CONSTRUCTION AND PRIOR TO SCHEDULING EARTHMOVING OR OTHER CONSTRUCTION ACTIVITIES WHICH LEAVE LARGE DISTURBED AREAS UNSTABILIZED. IF INCLEMENT WEATHER IS PREDICTED, USE BEST PROFESSIONAL JUDGEMENT AND GOOD CONSTRUCTION PRACTICES WHEN SCHEDULING CONSTRUCTION ACTIVITIES AND ENSURE THE NECESSARY EROSION CONTROL DEVICES ARE INSTALLED AND FUNCTIONING PROPERLY TO MINIMIZE EROSION FROM ANY IMPENDING WEATHER EVENTS.
7. INSPECT EROSION AND SEDIMENT CONTROL DEVICES AND STABILIZED SLOPES ON A WEEKLY BASIS AND AFTER EACH RAINFALL EVENT OF .25 INCH OR GREATER. REPAIR IDENTIFIED PROBLEMS WITHIN 24 HOURS TO ENSURE EROSION AND SEDIMENT CONTROLS ARE IN GOOD WORKING ORDER. RESET OR REPLACE MATERIALS AS REQUIRED.
8. SURROUND THE PERIMETER OF SOIL STOCKPILES WITH SILT SOCK, SILT FENCE, STRAWBALES, OR A COMBINATION OF SILT FENCE WITH STRAWBALE, AS DETERMINED NECESSARY.
9. DISTURBED AREAS AND SLOPES MUST NOT BE LEFT UNATTENDED OR EXPOSED FOR EXCESSIVE PERIODS OF TIME SUCH AS THE INACTIVE WINTER SEASON. PROVIDE APPROPRIATE STABILIZATION PRACTICES ON ALL DISTURBED AREAS AS SOON AS POSSIBLE BUT NOT MORE THAN 14 DAYS AFTER THE CONSTRUCTION ACTIVITY IN THAT AREA HAS TEMPORARILY OR PERMANENTLY CEASED. REINFORCE TEMPORARY AREAS HAVING A SLOPE GREATER THAN 4:1 WITH EROSION BLANKETS OR APPROVED EQUIVALENT UNTIL THE SITE IS PROPERLY STABILIZED. TEMPORARY SWALES MAY ALSO BE REQUIRED IF DETERMINED NECESSARY IN THE FIELD BY THE ENGINEER.
10. INSTALL A CATCH BASIN INSERT OR APPROVED EQUIVALENT IN EACH EXISTING CATCH BASIN RECEIVING RUNOFF FROM THE SITE. UPON THE INSTALLATION OF EACH CATCH BASIN, INSTALL AN INSERT OR APPROVED EQUIVALENT. INSPECT SILT SOCKS, AFTER EACH SIGNIFICANT STORM EVENT AND REMOVE AND EMPTY AS NEEDED FOR THE DURATION OF THE CONSTRUCTION PERIOD.
11. SMALL SEDIMENTATION BASINS MAY BE CONSTRUCTED ON AN AS-NEEDED BASIS DURING CONSTRUCTION TO AID IN THE CAPTURE OF SITE RUNOFF AND SEDIMENT. IT WILL BE THE RESPONSIBILITY OF THE SITE CONTRACTOR, IN CONSULTATION WITH THE ENGINEER, TO SIZE AND CREATE THESE BASINS IN APPROPRIATE LOCATIONS.
12. CONTAIN ALL SEDIMENT ON SITE. SHEEP ALL EXITS FROM THE SITE AS NECESSARY INCLUDING ANY SEDIMENT TRACKING. SWEEP PAVED AREAS AS NEEDED TO REMOVE SEDIMENT AND POTENTIAL POLLUTANTS ACCUMULATED DURING SITE CONSTRUCTION.
13. REMOVE ACCUMULATED SEDIMENT FROM ALL TEMPORARY PRACTICES AND DISPOSE OF IN A PRE-APPROVED LOCATION.
14. TO ENSURE ALL EROSION AND SEDIMENTATION CONTROL DEVICES ARE PROPERLY MAINTAINED AND REPAIRED IN A TIMELY AND RESPONSIBLE MANNER, PROVIDE ON-SITE OR MAKE READILY AVAILABLE, THE NECESSARY EQUIPMENT AND SITE PERSONNEL DURING CONSTRUCTION HOURS FOR THE DURATION OF THE PROJECT. IF SITE WORK IS SUSPENDED DURING THE WINTER MONTHS THE CONTRACTOR MUST CONTINUE TO PROVIDE PERSONNEL AND EQUIPMENT ON-SITE OR READILY AVAILABLE.
15. PRIOR TO THE INSTALLATION OF FILTER FABRIC AND MEDIA, WITHIN THE BIORETENTION AREAS, REMOVE AND PROPERLY DISPOSE OF SEDIMENT ACCUMULATED IN ANY PARTIALLY CONSTRUCTED OR TEMPORARY BIORETENTION/DRAINAGE AREA USED FOR SEDIMENT CONTROL DURING CONSTRUCTION. PROVIDE A SURFACE ELEVATION AT A MINIMUM 1-FOOT ABOVE THE BOTTOM OF MEDIA ELEVATION AS SHOWN IN THE BIORETENTION SCHEDULE FOR PARTIALLY CONSTRUCTED BIORETENTION AREAS. THIS ALLOWS FOR AN OVER-DIG OF THE COLLECTED SEDIMENT FROM WITHIN THE BIORETENTION AREA PRIOR TO MEDIA/FABRIC INSTALLATION.
16. CONTROL DUST BY WATERING OR OTHER APPROVED METHODS AS NECESSARY. OR AS DIRECTED BY THE ENGINEER.
17. THE CONTRACTOR IS RESPONSIBLE FOR THE INSPECTION AND MAINTENANCE DURING CONSTRUCTION OF ALL STORMWATER FACILITIES INSTALLED OR AFFECTED BY THE PROJECT. REMOVE SEDIMENT OR DEBRIS COLLECTED WITHIN THESE FACILITIES FROM THE PROJECT WORK PRIOR TO THE OWNER'S ACCEPTANCE.

DEWATERING

1. A HIGH WATER TABLE IS NOT ANTICIPATED. HOWEVER, IF THE WATER TABLE IS ENCOUNTERED DURING EXCAVATION, TEMPORARILY LOWER THE WATER TABLE BY PUMPING AS INDICATED IN THE DEWATERING BAG DETAIL AND PROVIDE A DEWATERING PLAN FOR THE PROJECT. DIRECT THE PUMP DISCHARGE TO THIS BASIN TO PREVENT SEDIMENTS FROM LEAVING THE CONSTRUCTION AREA. INSTALL ADDITIONAL BASINS IF REQUIRED. INSTALL THE BASIN AS INDICATED ON DRAWINGS IF SO NOTED. OTHERWISE INSTALL THE BASIN(S) WITHIN THE LIMIT OF DISTURBANCE INDICATED BY THE SILT FENCE OR STRAWBALES.
2. PRIOR TO ANY DEWATERING, THE DEWATERING PLAN MUST BE APPROVED BY THE ENGINEER.
3. IF DEWATERING IS NECESSARY DURING CONSTRUCTION, IMPLEMENT THE PROPER ESC MEASURES ON SITE TO PREVENT EROSION OR SEDIMENT RUNOFF. THESE MEASURES CAN INCLUDE DEWATERING BAGS, TEMPORARY STRAWBALES, SILT FENCES, SILT SOCKS AND/OR OTHER APPROVED DEVICES AS INDICATED IN THE DETAILS.

STORMWATER FACILITY OPERATION & MAINTENANCE:

- THE CONTRACTOR IS RESPONSIBLE FOR THE STORMWATER POLLUTION PREVENTION PLAN (SWPPP) AND THE PROPER INSPECTION AND MAINTENANCE OF ALL STORMWATER MANAGEMENT FACILITIES AS OUTLINED BELOW UNTIL SUCH TIME THAT THE ROADWAYS AND ASSOCIATED UTILITIES ARE ACCEPTED BY THE OWNER AND THE ENGINEER. REFER TO THE APPROVED SWPPP FOR ADDITIONAL MAINTENANCE REQUIREMENTS.
1. MAINTAIN A WORKING COPY OF THE SWPPP ON-SITE AT ALL TIMES.
 2. INSPECT AND RESTORE/CLEAN ALL FACILITIES (INLETS, MANHOLES, INFILTRATION BASINS, ETC.) OF SEDIMENT AND DEBRIS PRIOR TO THE OWNER'S ACCEPTANCE.
 3. REMOVE AND DISPOSE ALL SEDIMENT AND DEBRIS AT A PRE-APPROVED LOCATION AS APPROVED BY THE TOWN.
 4. INSPECT AFTER EVERY MAJOR RAINFALL EVENT FOR THE ENTIRE DURATION OF THE CONSTRUCTION PROJECT AND THE FIRST 3 MONTHS AFTER CONSTRUCTION TO ENSURE PROPER STABILIZATION AND CONSTRUCTION.
 5. SPECIFIC MAINTENANCE REQUIRED DURING CONSTRUCTION AS FOLLOWS:
 - A. DRAINAGE STRUCTURES (INLETS, MANHOLES & CATCHBASINS): ALL DRAINAGE STRUCTURES WILL BE INSPECTED TO MONITOR FOR PROPER OPERATION. COLLECTION OF LITTER OR TRASH AND STRUCTURAL DEGRADATION OF BASINS WILL BE CLEANED OF SEDIMENT (INCLUDING SUMPS) AS NECESSARY, AND REPAIRED WHEN REQUIRED.
 - B. SEDIMENT FOREBAY: REMOVE SEDIMENT BUILD-UP ON THE FLOOR OF THE FOREBAY AND PROPERLY DISPOSE OF IN A PRE-APPROVED LOCATION ONCE EVERY YEAR, OR MORE OFTEN AS NECESSARY TO LIMIT SEDIMENT BUILDUP TO LESS THAN 50 PERCENT OF THE DESIGN VOLUME.
 - C. BIORETENTION SYSTEMS AND BIOSWALES: INSPECT AFTER STORM EVENTS GREATER THAN OR EQUAL TO THE 1-YEAR 24-HOUR PRECIPITATION EVENT, OR MORE FREQUENTLY AS NEEDED. REMOVE ANY TRASH AND/OR DEBRIS. CORRECT ANY EROSION OR GULLING. REMOVE AND REPLACE ESTABLISHED, DEAD OR SEVERELY DISEASED PLANTS ANNUALLY.
 - D. ENHANCED TREE TRENCH: INSTALL CATCH BASIN INSERTS. INSPECT STRUCTURE AFTER STORM EVENTS GREATER THAN OR EQUAL TO THE 1-YEAR, 24-HOUR PRECIPITATION EVENT, OR MORE FREQUENTLY AS NEEDED. THE BASINS WILL BE CLEANED OF SEDIMENT (INCLUDING SUMPS) AS NECESSARY, AND REPAIRED WHEN REQUIRED.
 - E. TREE FILTER PITS: ALL TREE FILTER PITS WILL BE INSPECTED TO MONITOR FOR PROPER OPERATION, COLLECTION OF LITTER OR TRASH, AND STRUCTURAL DEGRADATION OF THE BASIN AND SEDIMENT FOREBAYS WILL BE CLEANED OF SEDIMENT (INCLUDING SUMPS) AS NECESSARY, AND REPAIRED WHEN REQUIRED.
 - F. ROUTINE MAINTENANCE: OTHER ROUTINE MAINTENANCE INCLUDING THE REMOVAL OF TRASH AND LITTER FROM PAVED AND PERIMETER AREAS, AND ANNUAL STREET AND PARKING LOT SWEEPING AFTER THE SPRING THAW TO AVOID EXCESSIVE ACCUMULATION OF SEDIMENT IN THE DRAINAGE SYSTEM. INSPECT THE PIPES DRAINING THE PROJECT ANNUALLY FOR PROPER FLOW.

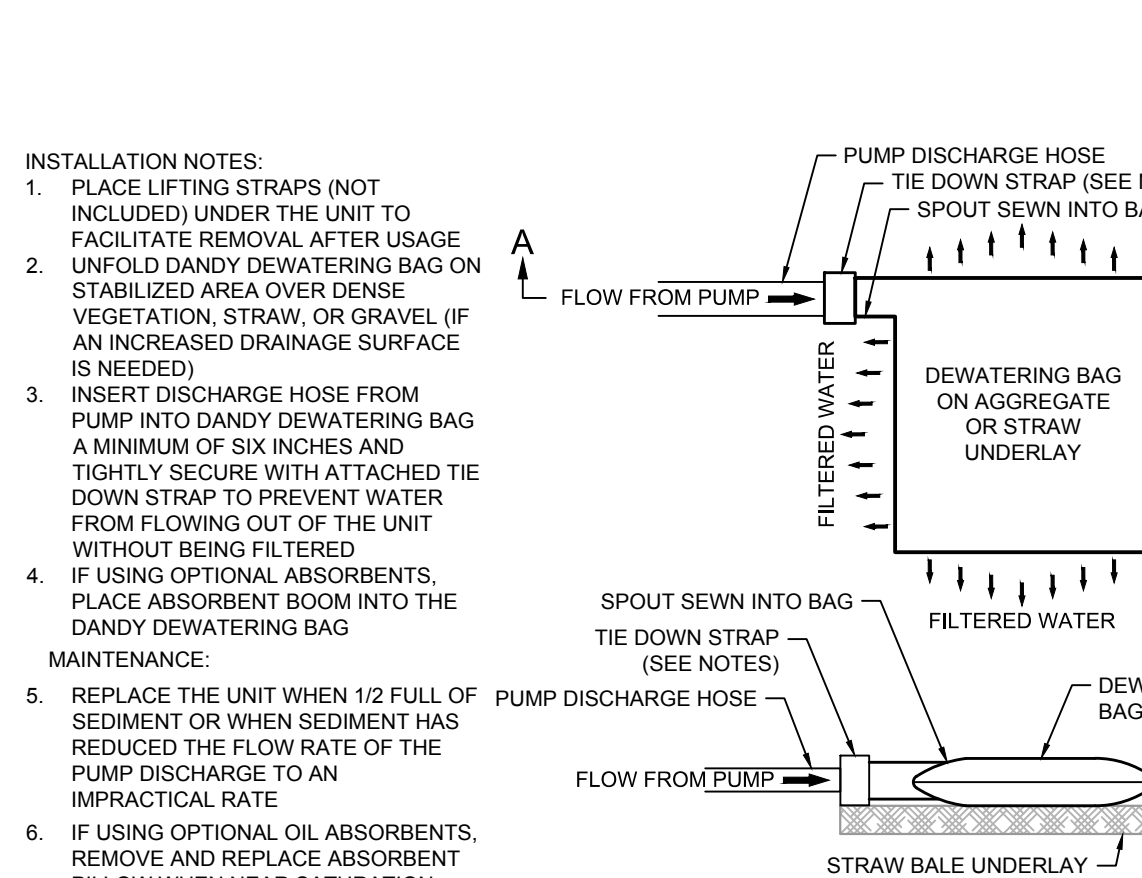
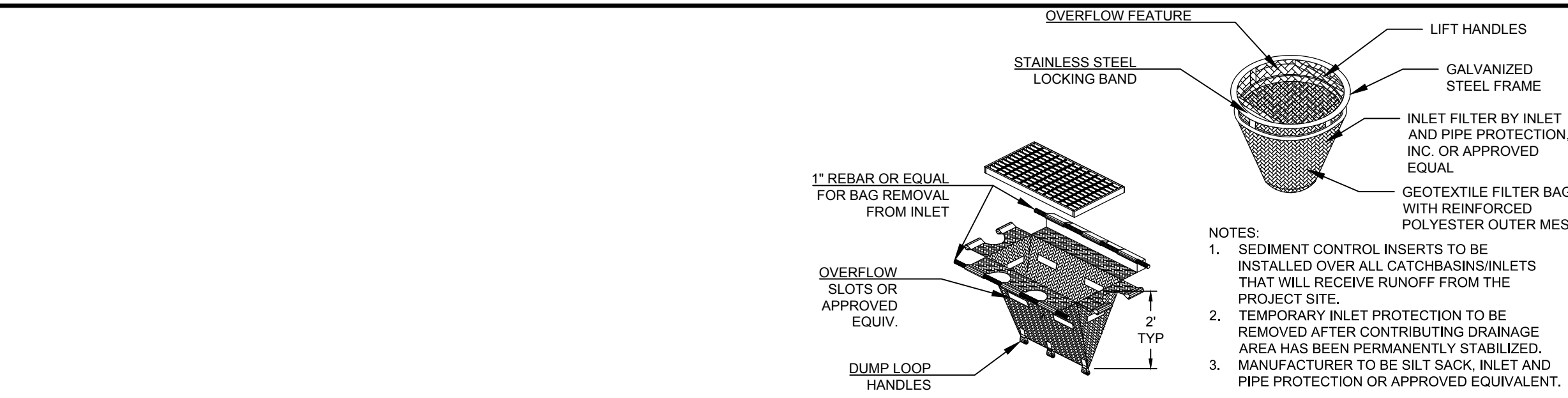

SILT SOCK

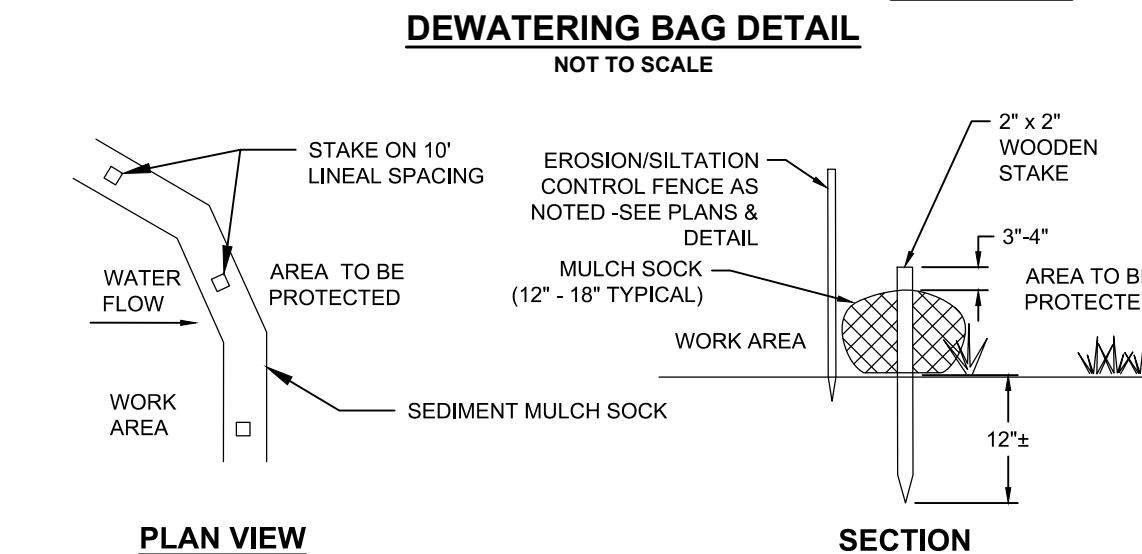

- NOTES:
1. MULCH SOCK MANUFACTURER TO BE SILT SOCK OR ENGINEER APPROVED EQUIVALENT.
 2. ALL MATERIAL TO MEET MANUFACTURER'S SPECIFICATIONS.
 3. SEDIMENT MULCH SOCK TO BE FILLED WITH MULCH COMPOST AND/OR WOODY MULCH PER MANUFACTURER'S REQUIREMENTS.
 4. FOLLOWING CONSTRUCTION AND SITE STABILIZATION, COMPOST MATERIAL TO BE REMOVED OR DISPERSED ON SITE, AS APPROVED BY THE ENGINEER.

TREE PROTECTION

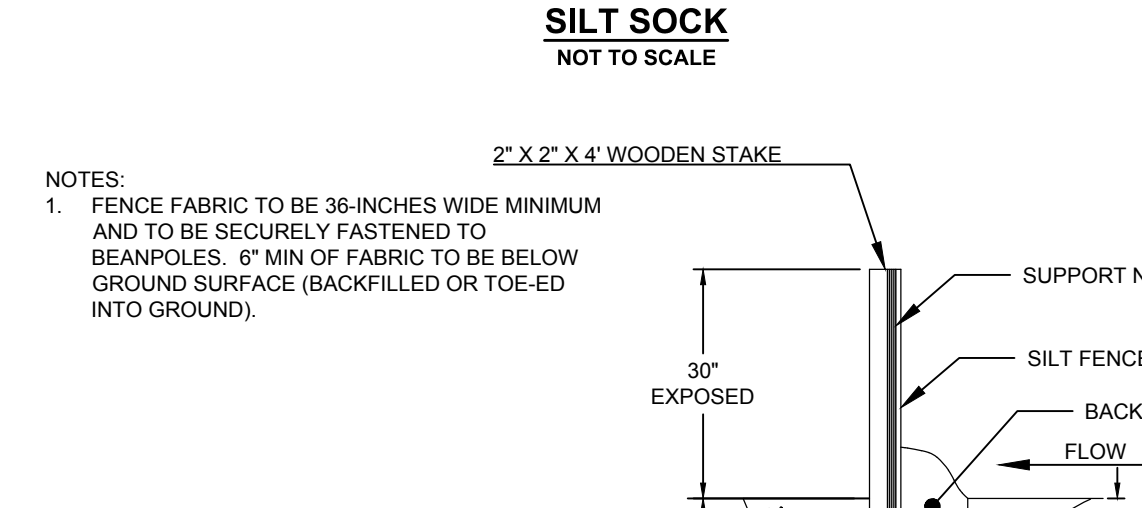

ALTERNATE TOP SLAB

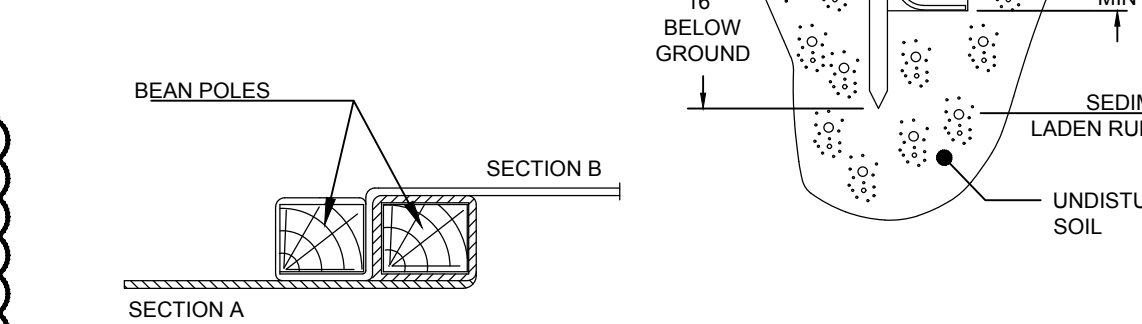

IN GRASS

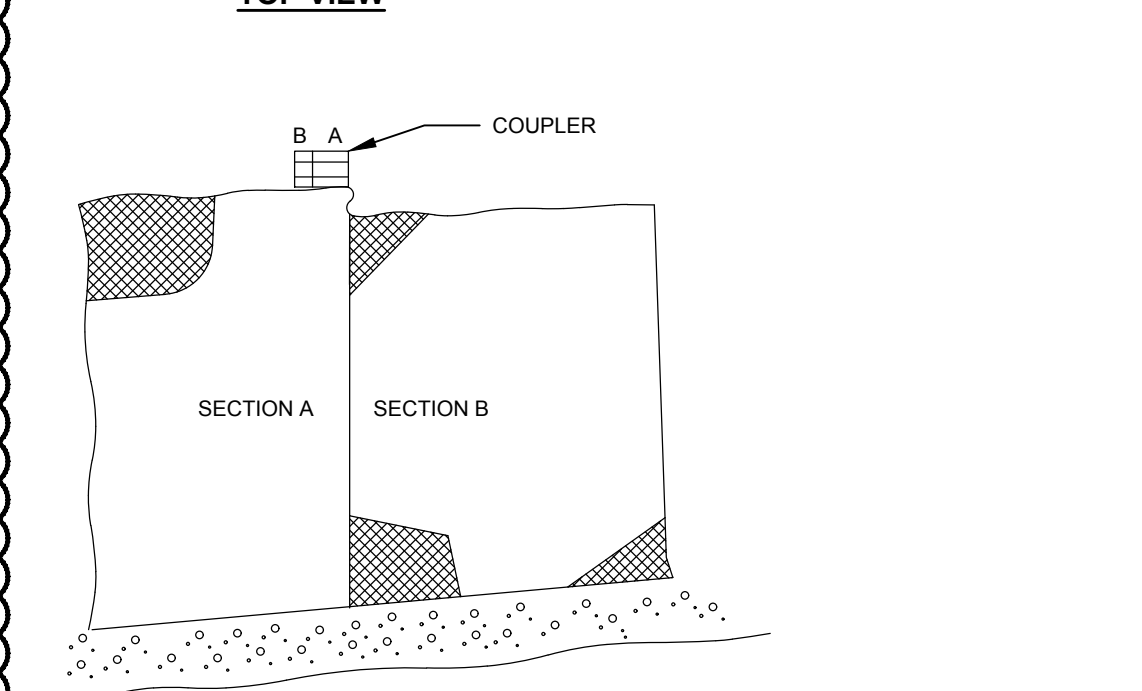

JOINING SECTIONS OF FENCE



SILT FENCE

SILT FENCE
NOT TO SCALE

BARNSTABLE
MARSTONS MILLS VILLAGE CENTER IMPROVEMENTS

SHEET NO.	TOTAL SHEETS
9	108

CONSTRUCTION NOTES & DETAILS
SHEET 5 OF 10

REV #	DATE
1	11/28/18

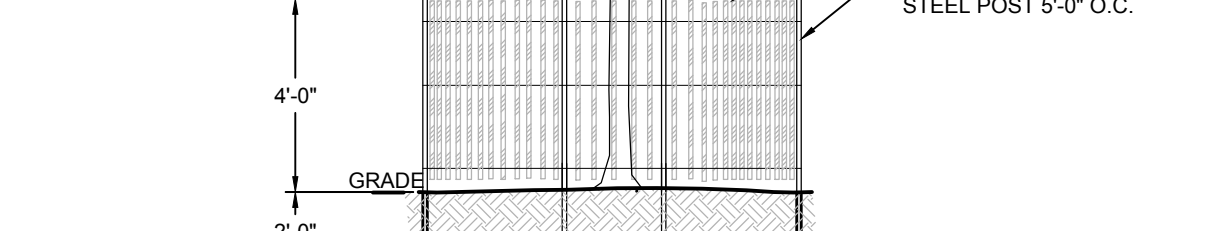
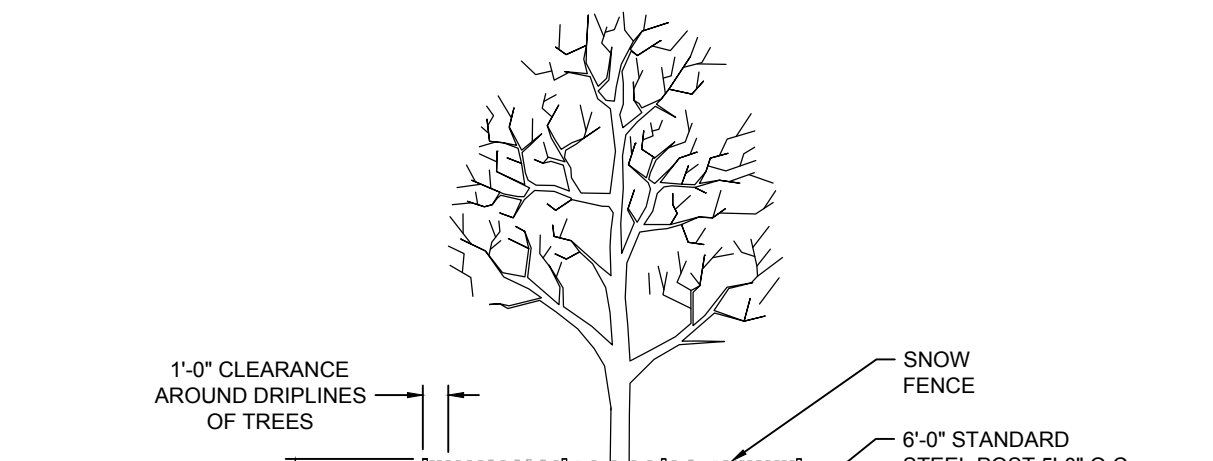
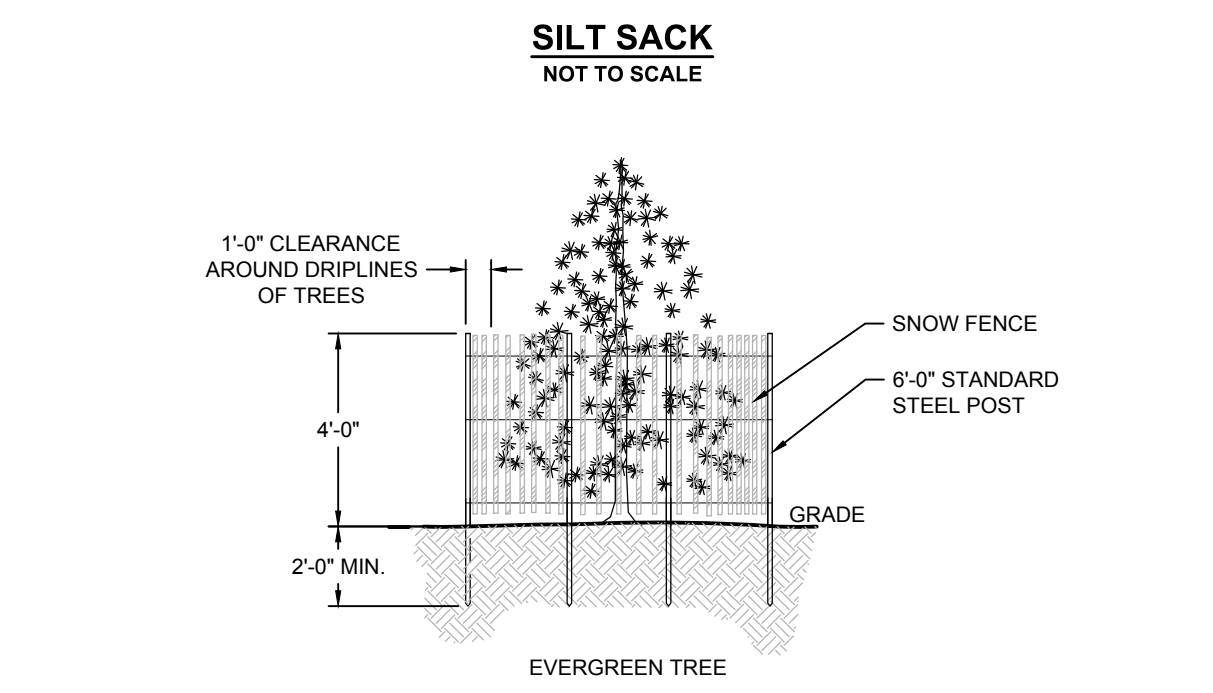

- NOTES:
1. FRAME AND COVER TO CONFORM TO MASSACHUSETTS STANDARDS HEAVY DUTY (EAST JORDAN, NEEHAH, OR APPROVED EQUIVALENT)
 2. ALL H2O LOADING.
 3. MIN. FRAME WEIGHT: 4" FLANGE 295 LBS, 3" FLANGE 265 LBS
 4. MATERIAL - CAST IRON
 5. MIN. GRATE WEIGHT: 200LBS.
 6. SEE CATCHBASIN AND MANHOLE DETAILS FOR INSTALLATION.

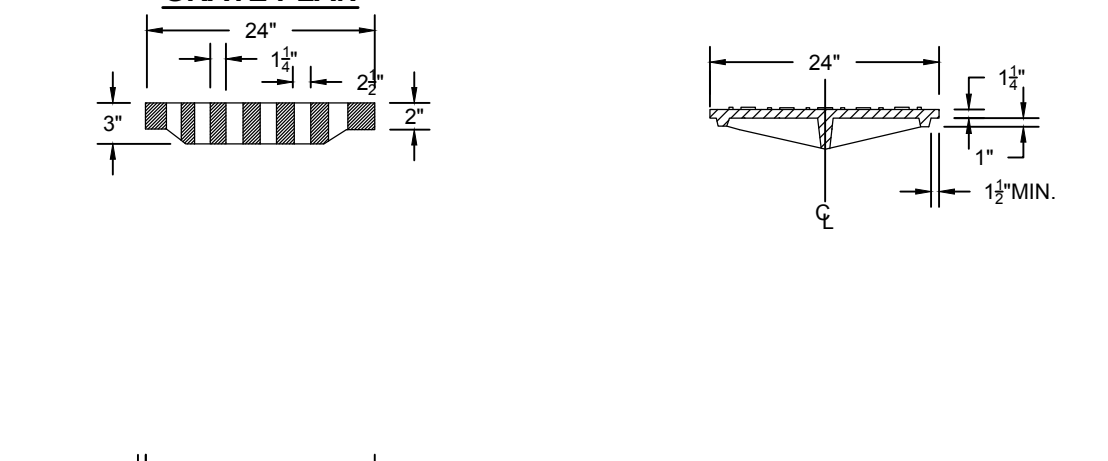
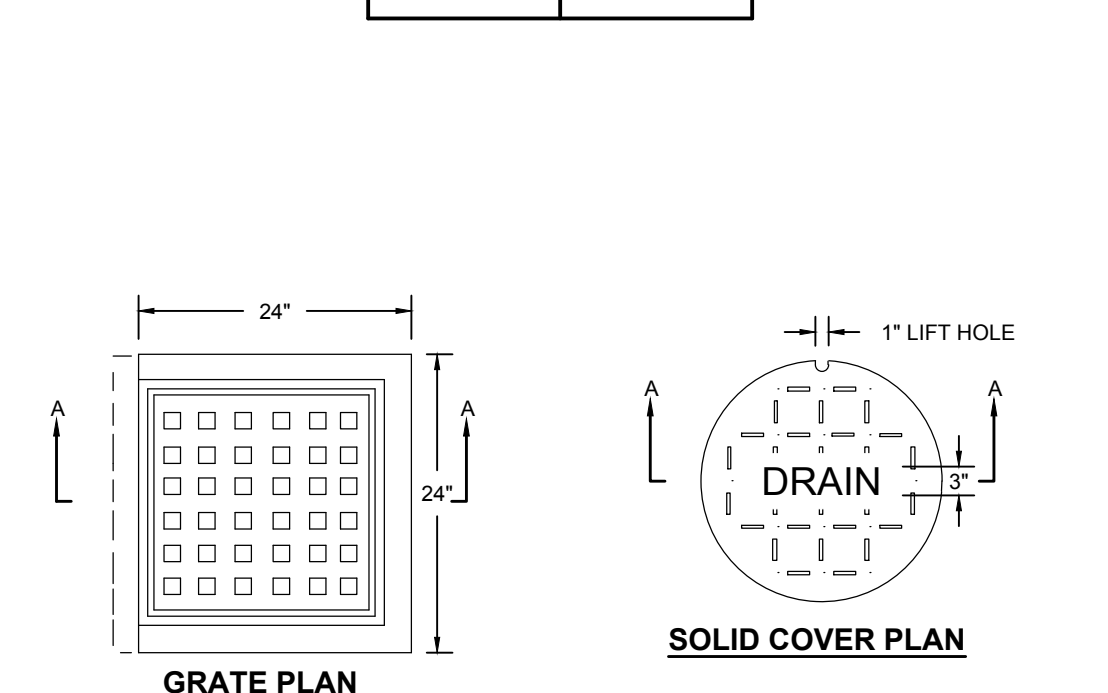

- NOTES:
1. ALL SECTIONS TO BE DESIGNED FOR H-20 LOADING.
 2. COPOLYMER MANHOLE STEPS TO BE INSTALLED AT 12" O.C. FOR THE FULL DEPTH OF THE STRUCTURE.
 3. PROVIDE "K" KNOCKOUTS FOR PIPES WITH 2" MAX. CLEARANCE TO OUTSIDE OF PIPE. MORTAR ALL PIPE CONNECTIONS.
 4. JOINT SEALANT BETWEEN PRECAST SECTIONS TO BE PRE-FORMED BUTYL RUBBER.
 5. CATCH BASIN FRAME AND GRATE TO BE SET IN FULL 12" MORTAR BED. ADJUST TO GRADE WITH PRECAST CONCRETE RISER OR BRICK.
 6. DO NOT PLACE MORTAR BED AROUND STRUCTURE UNTIL IT IS AT THE REQUIRED FINISH ELEVATION AND ALIGNMENT.
 7. FRAME AND COVER TO CONFORM TO MASSACHUSETTS STANDARDS HEAVY DUTY (EAST JORDAN, NEEHAH, OR APPROVED EQUIVALENT)
 8. HDPE PIPE HOOD TO BE 90° BEND. FASTENED TO PIPE WITH SEALANT. BEND TO HAVE 1 INCH PURGE HOLE DRILLED INTO TOP OF ELBOW.

TYPICAL DRAINAGE STRUCTURE FRAME AND COVER/GRATE
NOT TO SCALE

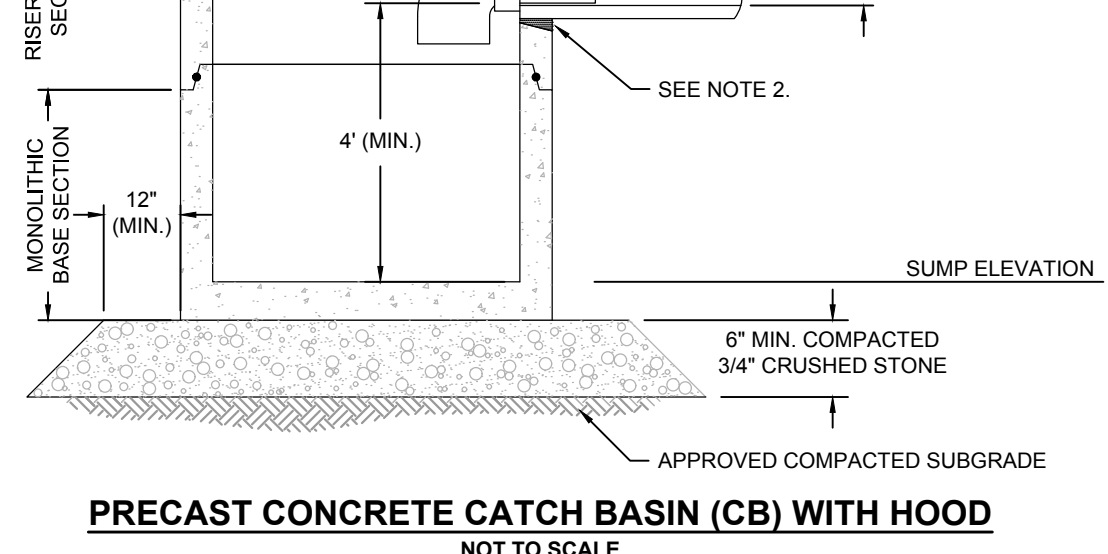
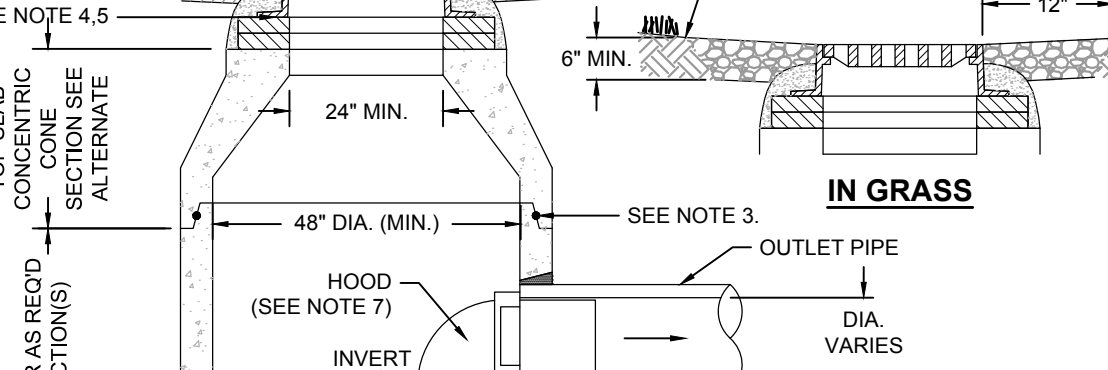
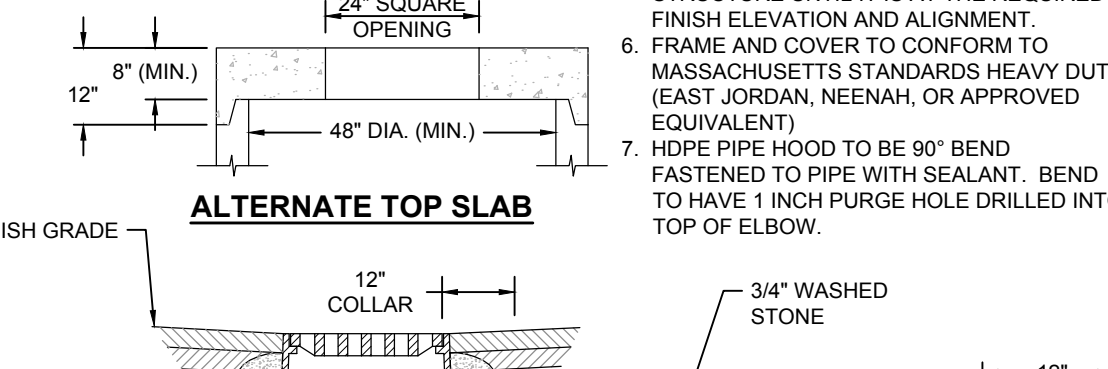
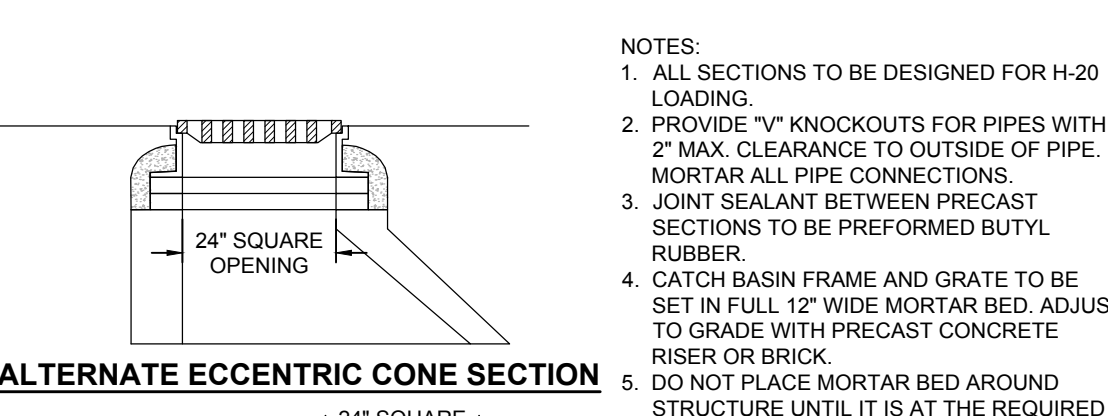

PRECAST CONCRETE CATCH BASIN (CB)
NOT TO SCALE

**BARNSTABLE
MARSTONS MILLS VILLAGE CENTER IMPROVEMENTS**

SHEET NO.	TOTAL SHEETS
10	108

**CONSTRUCTION DETAILS- DRAINAGE & BOARDWALK
SHEET 6 OF 10**

REV #	DATE
1	11/28/18

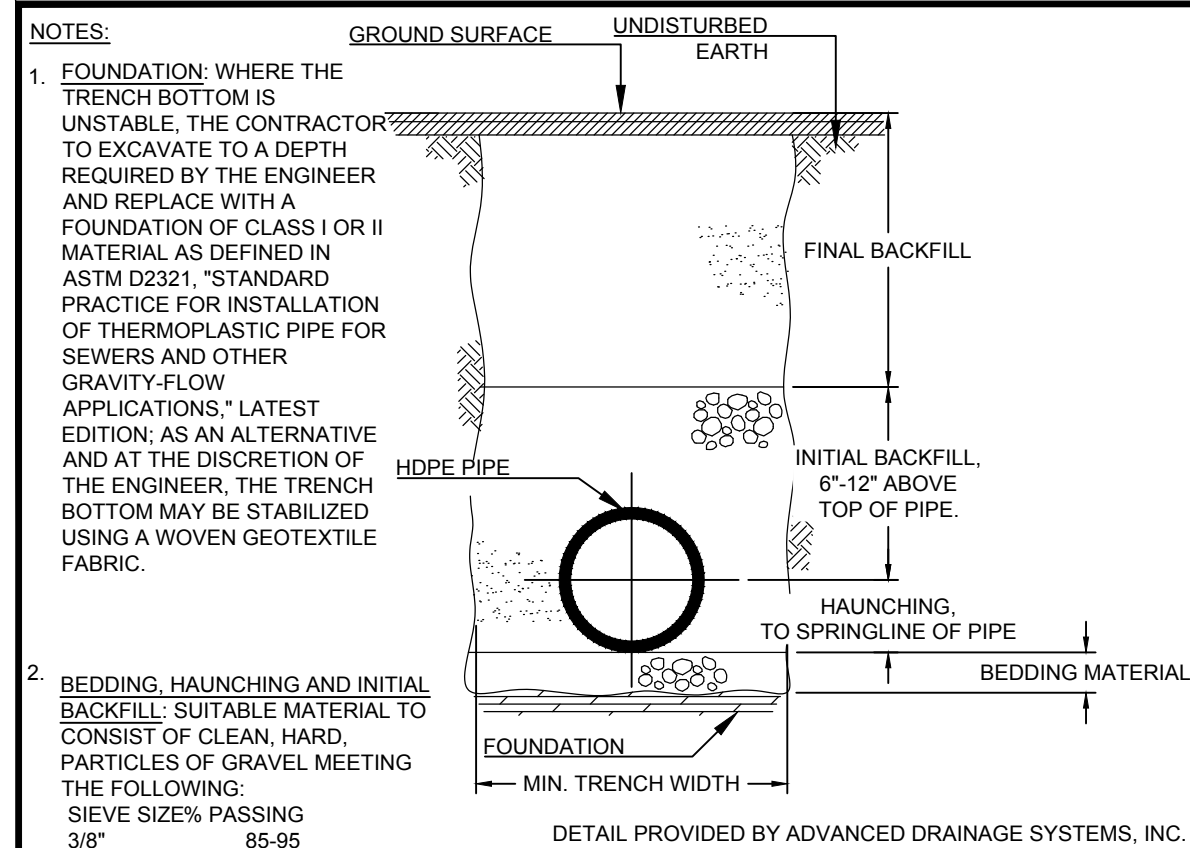

NOTES:

- FOUNDATION: WHERE THE TRENCH BOTTOM IS UNSTABLE, THE CONTRACTOR TO EXCAVATE TO A DEPTH REQUIRED BY THE ENGINEER AND REPLACE WITH A FOUNDATION OF CLASS I OR II MATERIAL AS DEFINED IN ASTM D2321, "STANDARD PRACTICE FOR INSTALLATION OF THERMOPLASTIC PIPE FOR SEWERS AND OTHER GRAVITY-FLOW APPLICATIONS," LATEST EDITION; AS AN ALTERNATIVE AND AT THE DISCRETION OF THE ENGINEER, THE TRENCH BOTTOM MAY BE STABILIZED USING A WOVEN GEOTEXTILE FABRIC.
- BEDDING, HAUNCHING AND INITIAL BACKFILL: SUITABLE MATERIAL TO CONSIST OF CLEAN, HARD, PARTICLES OF GRAVEL MEETING THE FOLLOWINGS:
SIEVE SIZE % PASSING
3/8" 85-95
NO. 4 5-15
NO. 8 0-2
MATERIAL TO BE INSTALLED AS REQUIRED IN ASTM D2321, LATEST EDITION.
- MINIMUM TRENCH WIDTHS TO BE AS FOLLOWS:

NOMINAL Ø in (mm)	MIN. RECOMMENDED TRENCH WIDTH, in (mm)
8 (200)	25 (630)
10 (250)	28 (710)
12 (300)	31 (790)
15 (375)	34 (860)
18 (450)	39 (990)

DETAIL PROVIDED BY ADVANCED DRAINAGE SYSTEMS, INC.

4. MINIMUM COVER: MINIMUM RECOMMENDED DEPTHS OF COVER FOR VARIOUS LIVE LOADING CONDITIONS ARE SUMMARIZED IN THE FOLLOWING TABLE. UNLESS OTHERWISE NOTED, ALL DIMENSIONS ARE TAKEN FROM THE TOP OF PIPE TO THE GROUND SURFACE.

SURFACE LIVE LOADING CONDITION	MINIMUM RECOMMENDED * COVER, in (mm)
H25 (FLEXIBLE PAVEMENT)	12 (300)
H25 (RIGID PAVEMENT) E80	12 (300)
RAILWAY HEAVY	24 (610)
CONSTRUCTION	48 (1220)

* TOP OF PIPE TO BOTTOM OF BITUMINOUS PAVEMENT
THE MINIMUM COVER FOR A HDPE PIPE IS 1'-0" FOR H-20 TRAFFIC LOADS IF INSTALLED IN ACCORDANCE WITH AASHTO SECTION 30. THIS IS BASED ON EMPIRICAL CALCULATION OF LOAD RESPONSE, MANUFACTURER'S TESTING AND FIELD EXPERIENCE WITH THE PIPE. AASHTO SPECIFICATIONS SECTION 18.4.1.5 DEFINES THE MINIMUM COVER AS "1D^{1/8} BUT NOT LESS THAN 12 INCHES". THIS COVER IS MEASURED FROM THE PIPE OD TO THE TOP OF A RIGID (CONCRETE) PAVEMENT OR THE BOTTOM OF A FLEXIBLE (BITUMINOUS) PAVEMENT. BOTH AASHTO AND ASTM, AS WELL AS MOST MANUFACTURERS, REQUIRE ADDITIONAL (TEMPORARY) COVER, MOUNDING OVER THE PIPE AND REMOVED FOR FINAL GRADING AND PAVING, IS SUFFICIENT FOR LARGE CONSTRUCTION VEHICLE LOADS.

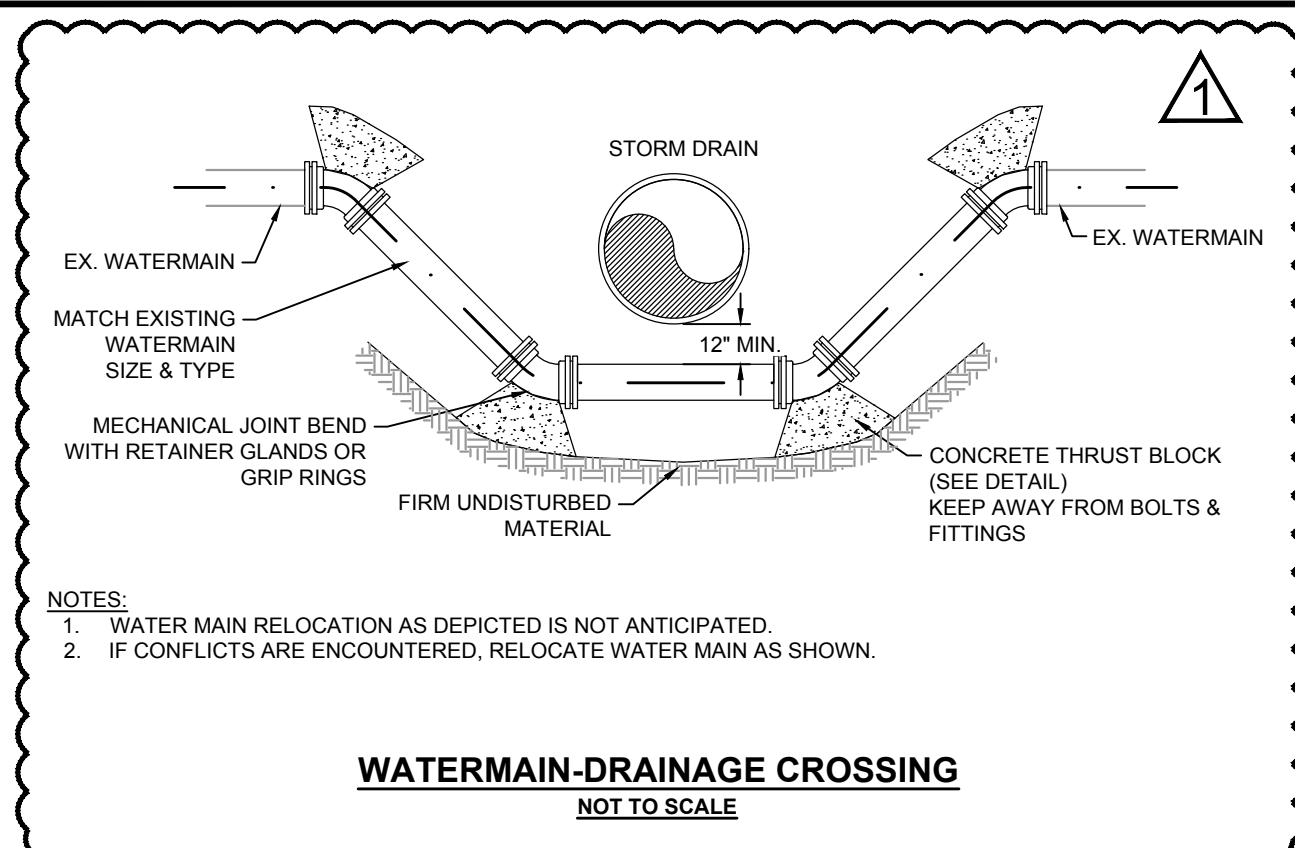

NOTES:

- WATER MAIN RELOCATION AS DEPICTED IS NOT ANTICIPATED.
- IF CONFLICTS ARE ENCOUNTERED, RELOCATE WATER MAIN AS SHOWN.

**WATERMAIN-DRAINAGE CROSSING
NOT TO SCALE**

**DRAINAGE PIPE TRENCH
NOT TO SCALE**

NOTES:

- ALL SECTIONS TO BE DESIGNED FOR H20 LOADING.
- PROVIDE 1/2" KNOCKOUTS FOR PIPES WITH 2" MAX. CLEARANCE TO OUTSIDE OF PIPE. MORTAR ALL PIPE CONNECTIONS.
- RECHARGE BASIN FRAME AND GRATE TO BE SET IN FULL MORTAR BED. ADJUST TO GRADE WITH PRECAST CONCRETE RISER.
- FRAME AND COVER SHALL CONFORM TO MASSACHUSETTS STANDARDS (LEBARON FOUNDRY, MODEL LK 110A, OR APPR. EQUIV.)
- GEOTEXTILE FILTER FABRIC TO BE MIRAFI 140N OR APPROVED EQUIVALENT
- SEE PLANS FOR ELEVATIONS AND INVERTS

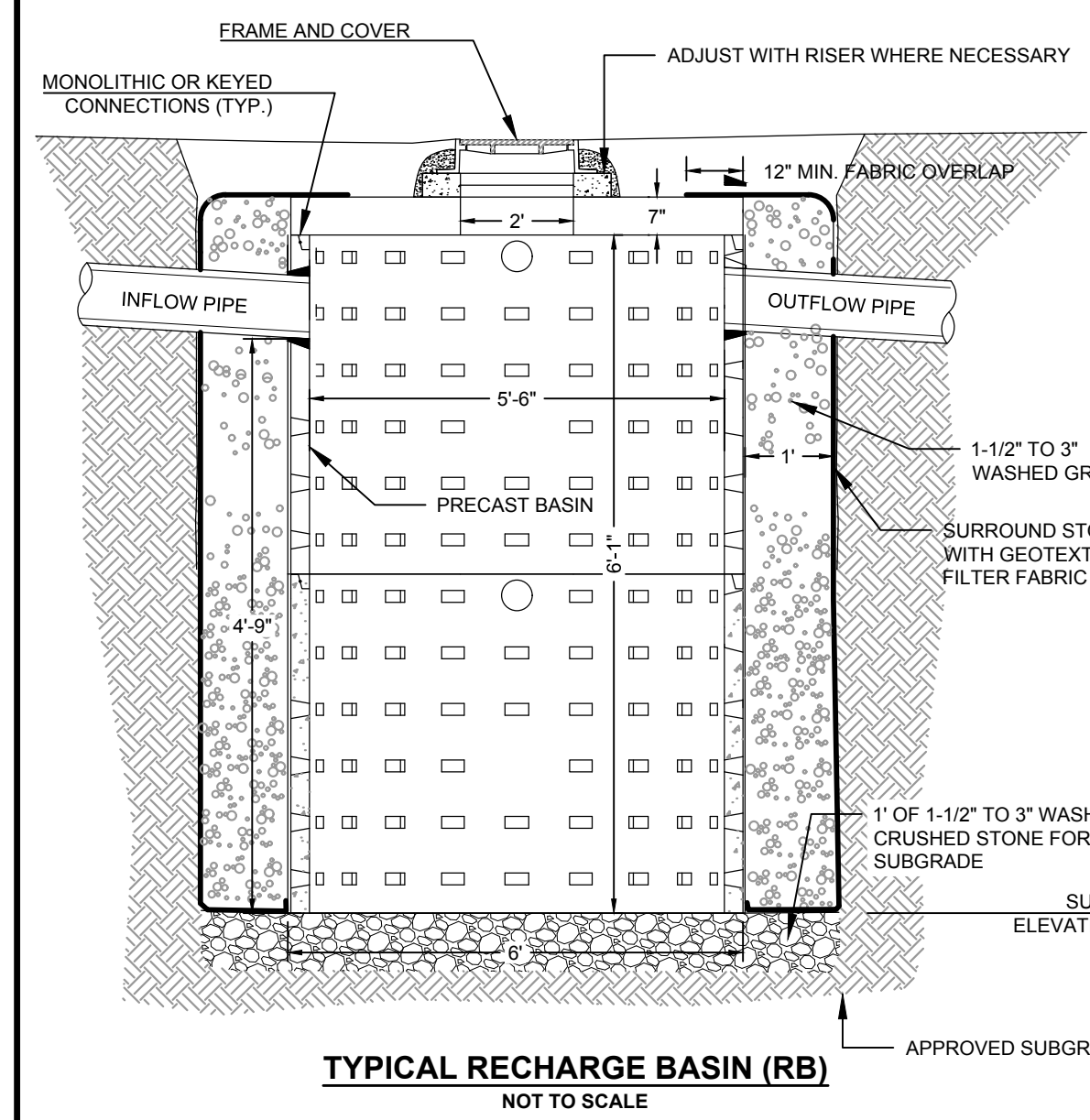

**TYPICAL RECHARGE BASIN (RB)
NOT TO SCALE**

NOTES:

- WORK OPERATIONS AS FOLLOWS UNLESS OTHERWISE APPROVED BY THE CONSERVATION COMMISSION AGENT AND ENGINEER.
- NO MACHINERY PERMITTED WITHIN THE EXISTING RESOURCE.
- FIELD SURVEY AND MARK CENTERLINE OF PATH OR LIMIT OF WORK (PATH EXTENTS). REQUEST REVIEW OF PATH LAYOUT WITH THE ENGINEER.
- CLEAR AND GRUB VEGETATION AND CUT TREES (TRUNKS, LIMBS, BRANCHES) TO FACILITATE CONSTRUCTION OF THE BOARDWALK. SEE INVASIVE PLANT SPECIES MANAGEMENT NOTES.
- REMOVE AND PROPERLY DISPOSE OF THE DEBRIS.
- REMOVE AND DISPOSE OF ROCK/BOULDERS AND ANY OTHER NATURAL OBSTRUCTION AS NECESSARY.
- INSTALL EROSION CONTROL.
- INSTALL HELICAL PILES FOR BOARDWALK.
- SEED AND RE-VEGETATE AREA UNDER BOARDWALK AS NOTED. SEE LANDSCAPE PLANS AND DETAILS.
- FRAME BOARDWALK.

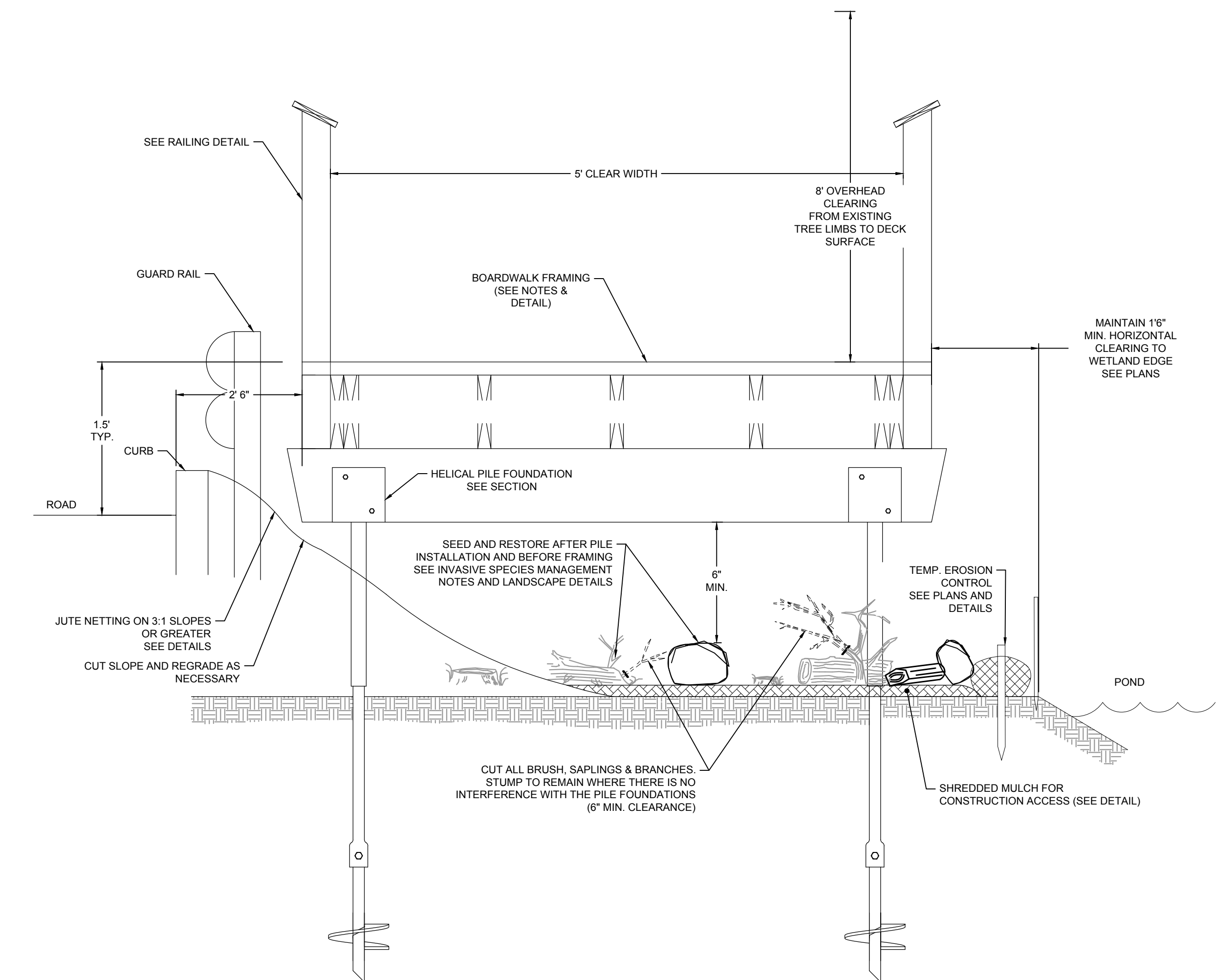

**TYPICAL BOARDWALK AND POND EDGE
RESTORATION SECTION
NOT TO SCALE**

NOTES:

- A FINAL DESIGN OF THE HELICAL PIER SUPPORT SYSTEM, SIGNED AND SEALED BY A MASSACHUSETTS LICENSED STRUCTURAL P.E., IS TO BE PROVIDED BY THE HELICAL PILE MANUFACTURER. SEE THE SPECIFICATIONS.
- THE BOARDWALK AND WOOD FRAMING TO BE CONSTRUCTED PER THE APPLICABLE BOARDWALK DETAILS.
- DETAIL PROVIDED BY HUBBELL POWER SYSTEMS (CHANGE).
- HELICAL PIERS CAN BE EITHER SINGLE OR MULTHELIX. THE NUMBER AND SIZE OF HELIX PLATES VARY DEPENDING ON PIER LOAD AND SOIL CONDITIONS.
- HELICAL PIERS ARE INSTALLED (SCREWED) TO A MINIMUM DEPTH AND TORQUE AS REQUIRED BY THE MANUFACTURER WITH THE SOIL INFORMATION.
- HELICAL PIER SHAFTS FOR WALKWAY SUPPORT ARE TYPICALLY 1-1/2" OR 1-3/4" SQUARE SHAFT OR 2-7/8" O.D. PIPE SHAFT.
- CROSS BRACE PILES FOR LATERAL SUPPORT ARE REQUIRED WHERE DECK ELEVATION EXCEEDS 3-FEET ABOVE SURFACE GRADE. CROSS BRACES MAY ALTERNATE EVERY OTHER SPLIT CAP (BENT) WHERE SOIL CONDITIONS ALLOW.
- PILE DEPTH: WHERE MINIMUM DEPTH OF PILE AS SPECIFIED CANNOT BE MAINTAINED CROSS BRACE BATTERING MUST BE PERFORMED TO PROVIDE THE REQUIRED LOADING.
- ALL HARDWARE HOT DIPPED GALVANIZED PER ASTM A-153. MATERIAL FOR SADDLE HOT ROLLED STEEL.
- FINISHED BOARDWALK STRUCTURE TO MEET OR EXCEED INTERNATIONAL BUILDING CODE REQUIREMENTS FOR THE LOADING CAPACITIES BELOW:

WOOD DECKING AND FRAMING
LIVE LOAD: PER DETAILS PROVIDED WITH MINIMUM 100 POUNDS PER SQUARE FOOT (PSF)

HELICAL PIER FOUNDATION
VEHICULAR LIVE LOAD: AASHTO H5 (10,000 POUND VEHICLE WITH 2,000 POUND FRONT AXLE AND 8,000 POUND REAR AXLE)

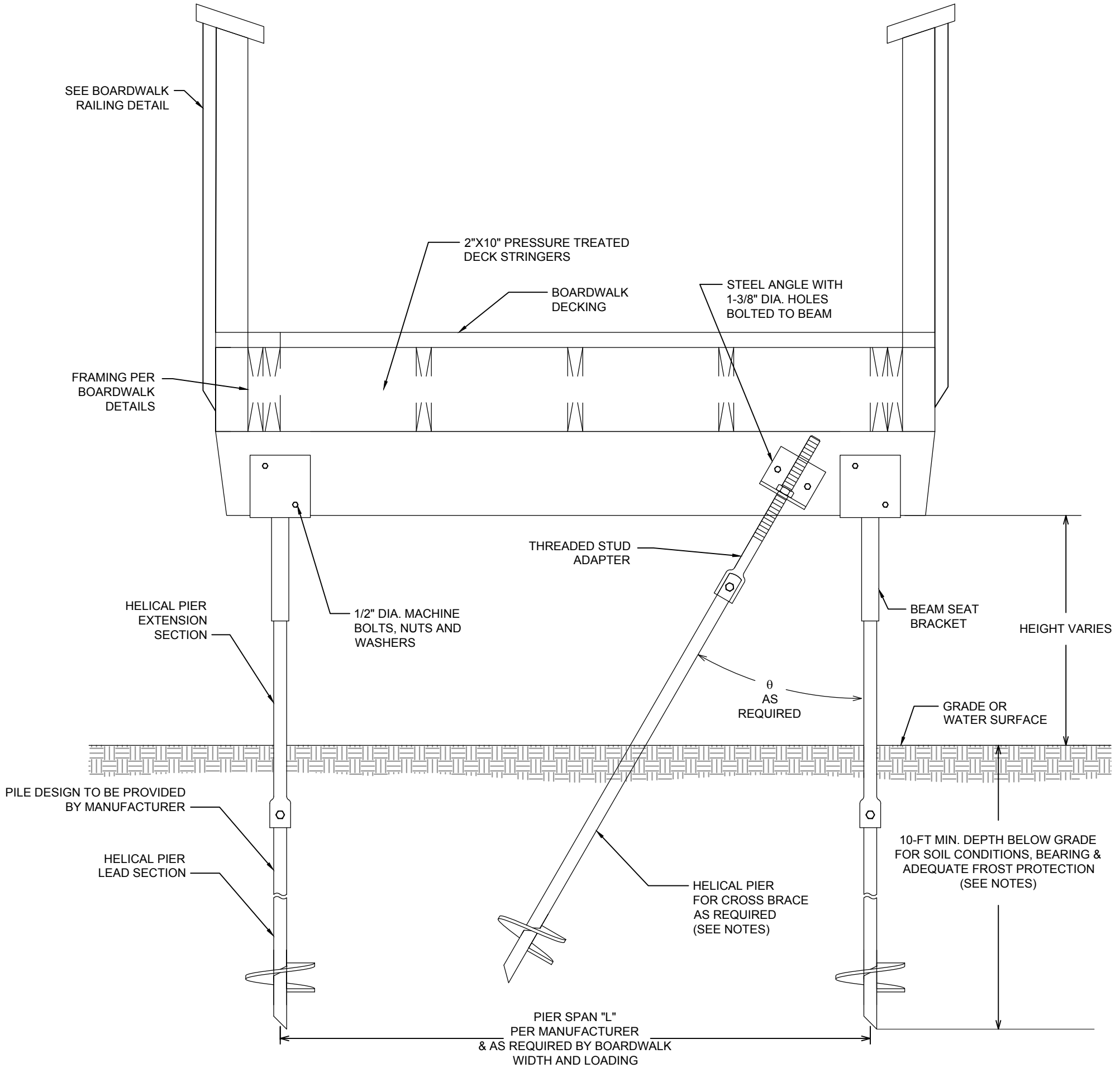

**TYPICAL HELICAL PILE FOUNDATION
SECTION
NOT TO SCALE**

SHEET NO.	TOTAL SHEETS
11	108

CONSTRUCTION DETAILS-BOARDWALK
SHEET 7 OF 10

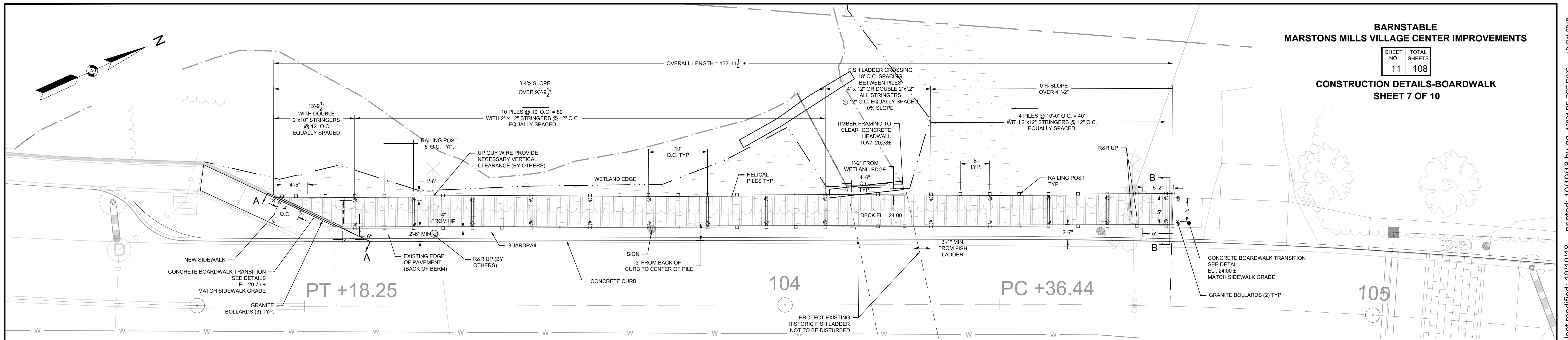

BOARDWALK FRAMING PLAN
SCALE: 1/8" = 1'-0"

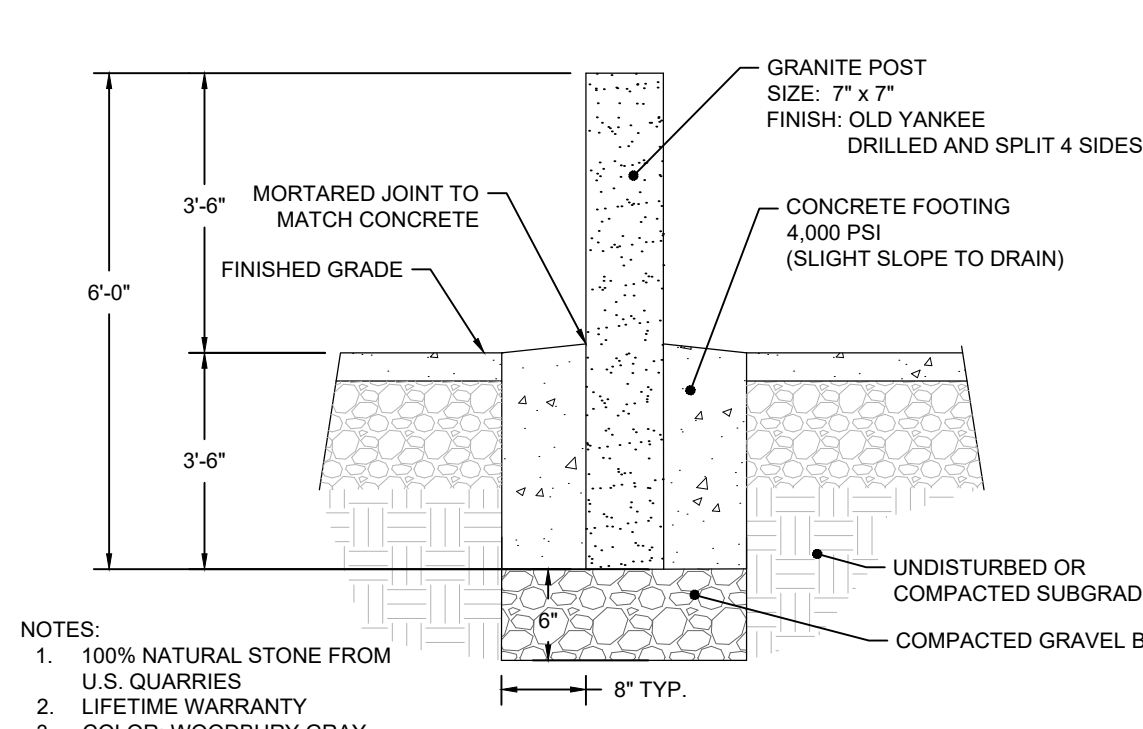
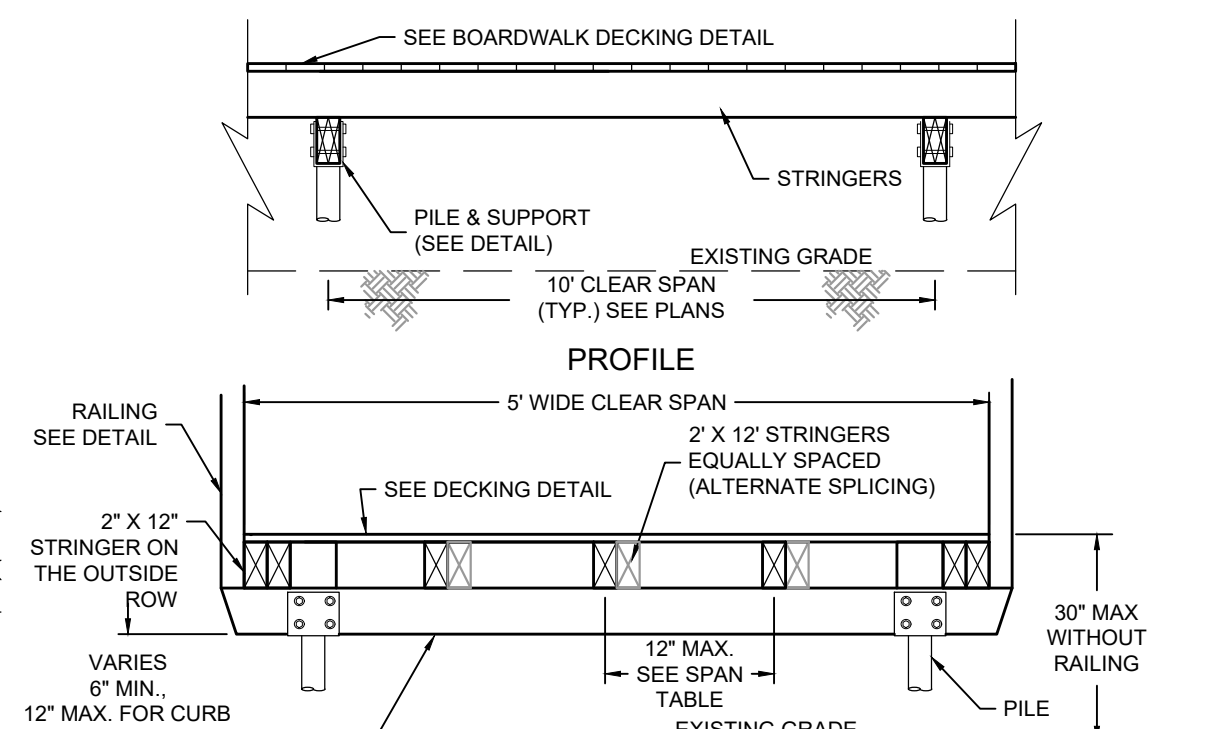
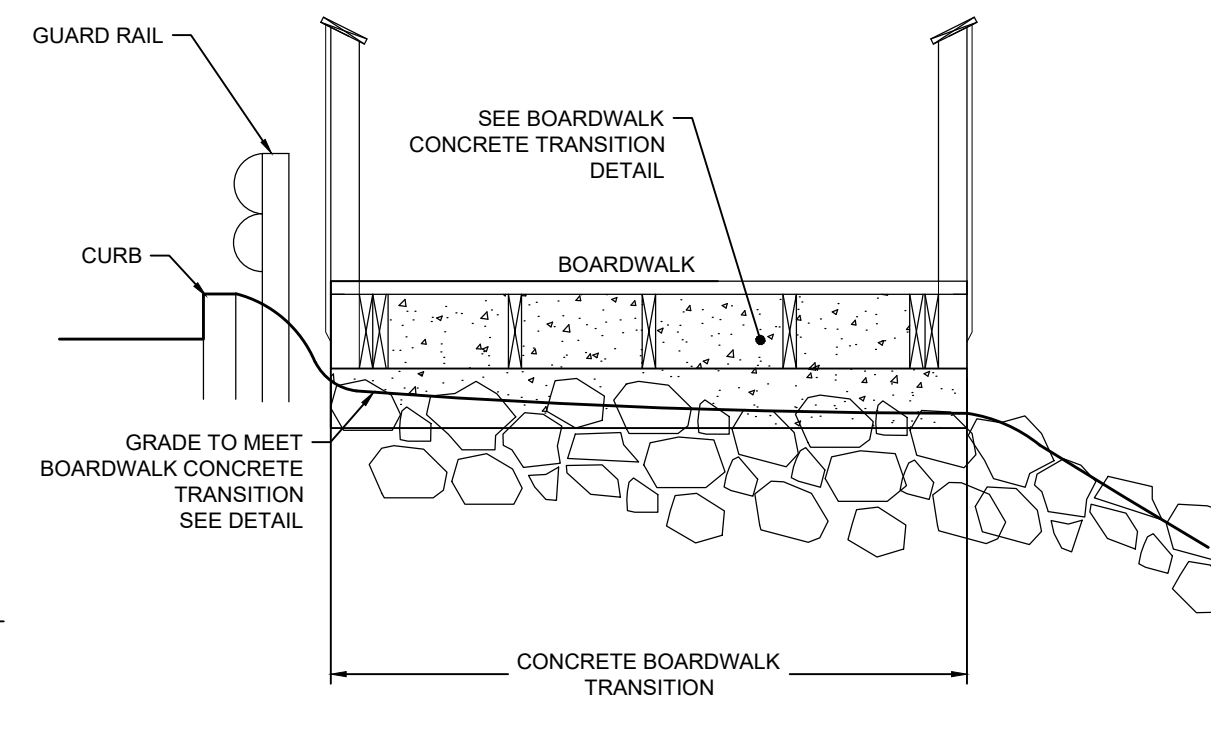
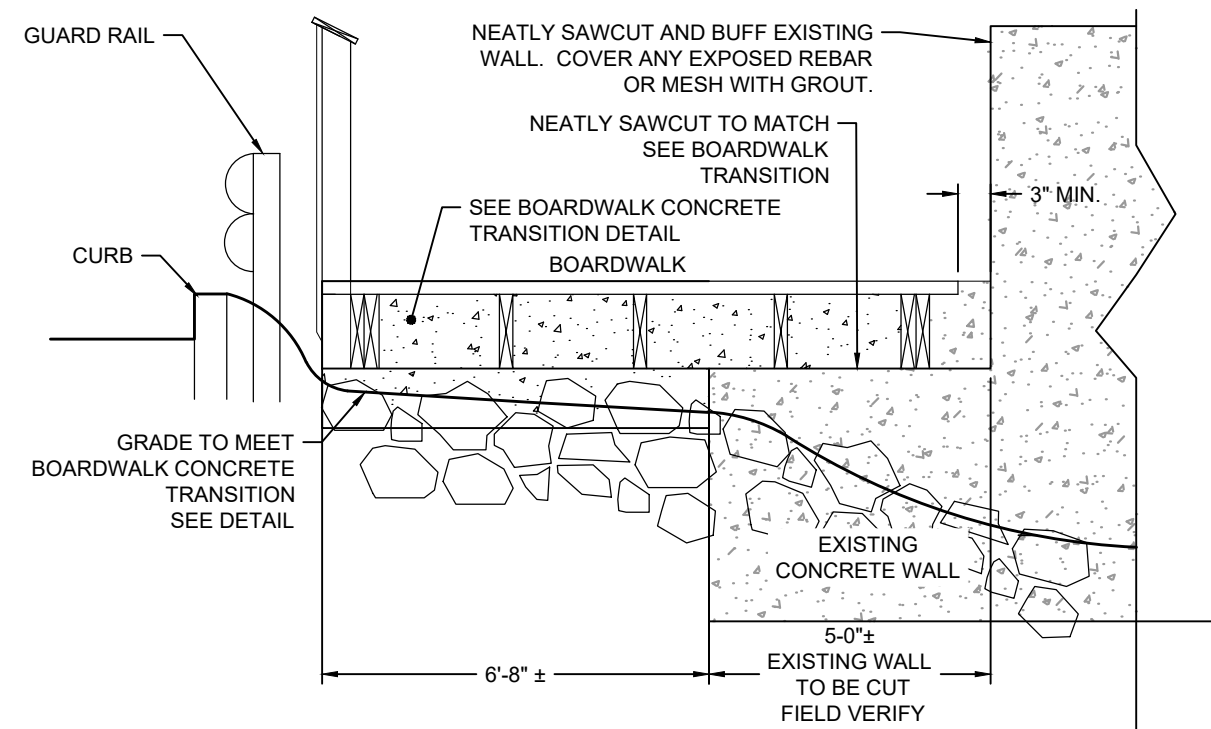

GENERAL FRAMING NOTES:

- FIELD LAYOUT OF THE BOARDWALK AND AND HELICAL PILES TO BE REVIEWED AND APPROVED BY ENGINEER PRIOR TO PILE INSTALLATION.
- THE BOARDWALK FRAMING SHOWN IS PLANK CONSTRUCTION AND SHALL BE CONSTRUCTED PER THE APPLICABLE BUILDING CODES AND DESIGN LOADS.
- ALL FRAMING HARDWARE SHALL BE HOT DIPPED GALVANIZED PER ASTM A-153 MATERIAL FOR SADDLE HOT ROLLED STEEL.
- FINISHED BOARDWALK STRUCTURE SHALL MEET OR EXCEED INTERNATIONAL BUILDING CODE REQUIREMENTS FOR THE LOADING CAPACITIES BELOW:

PEDESTRIAN LIVE LOAD: 100 PSF (MIN.)

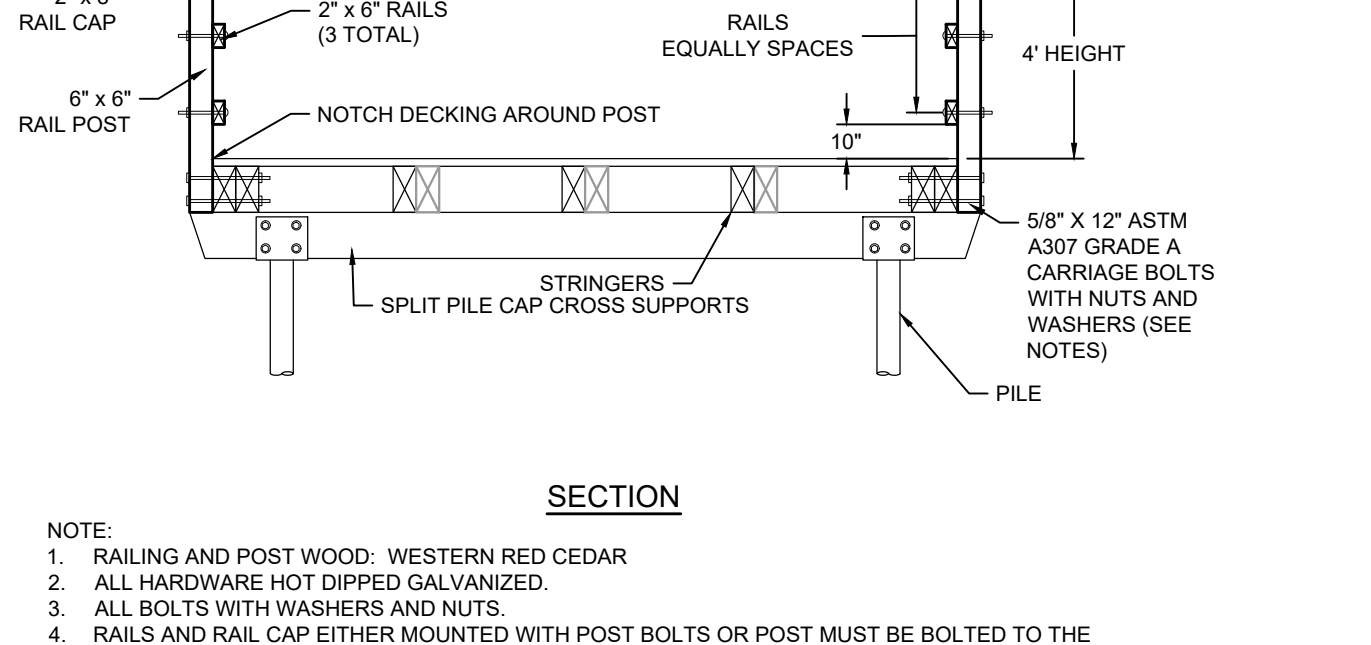
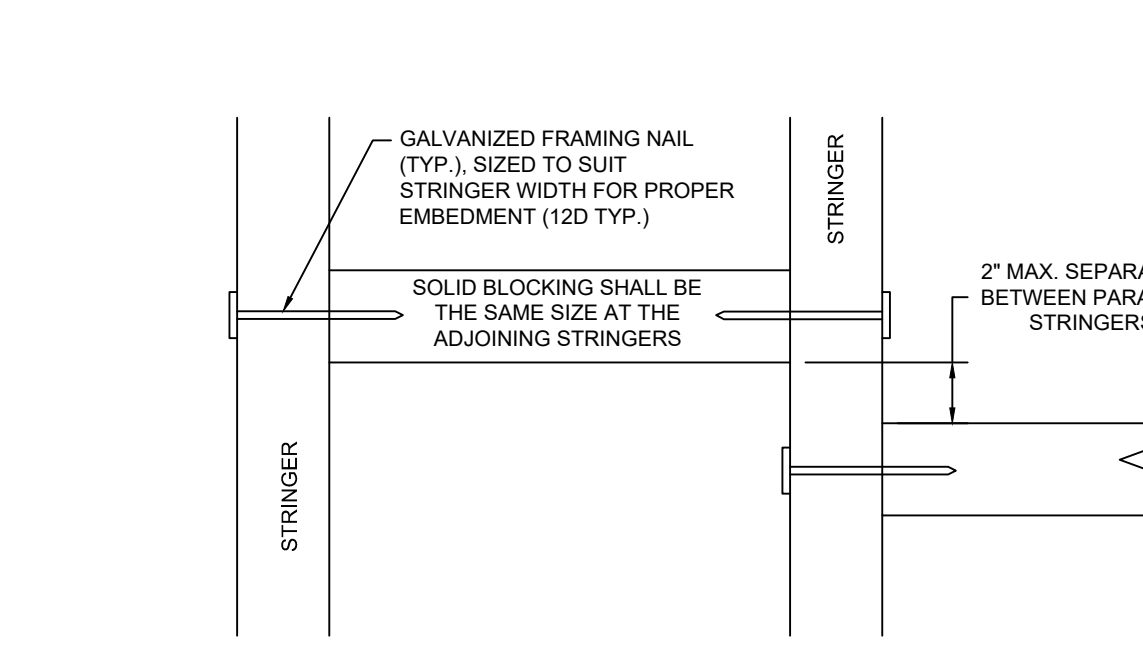
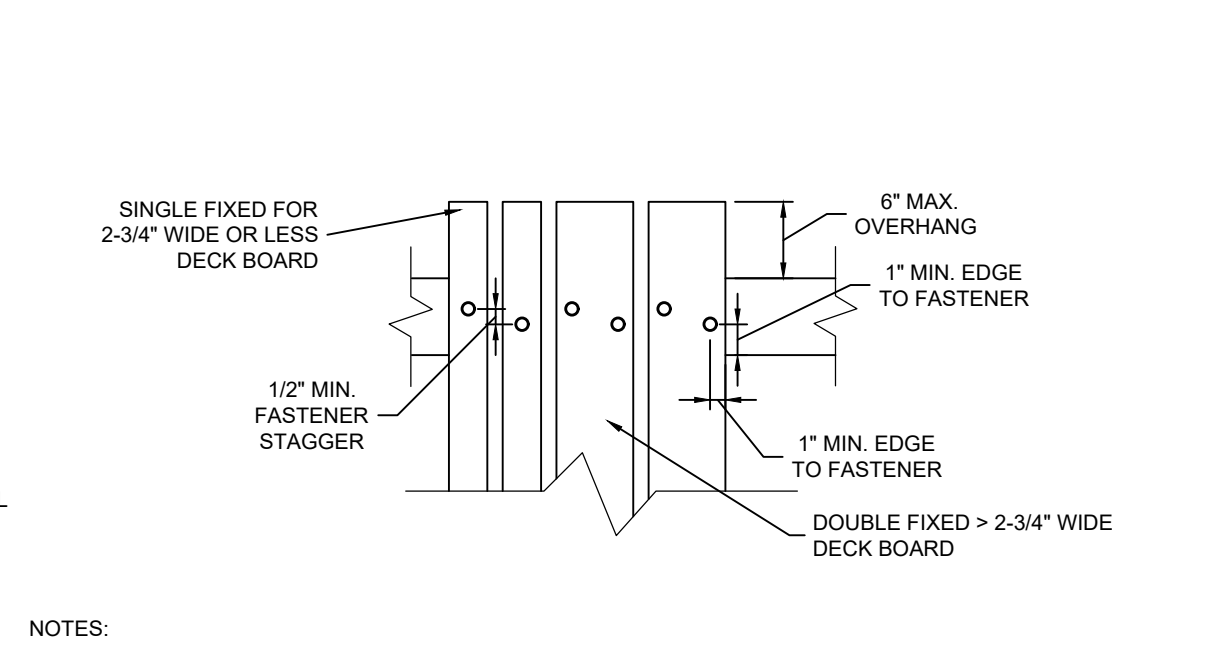
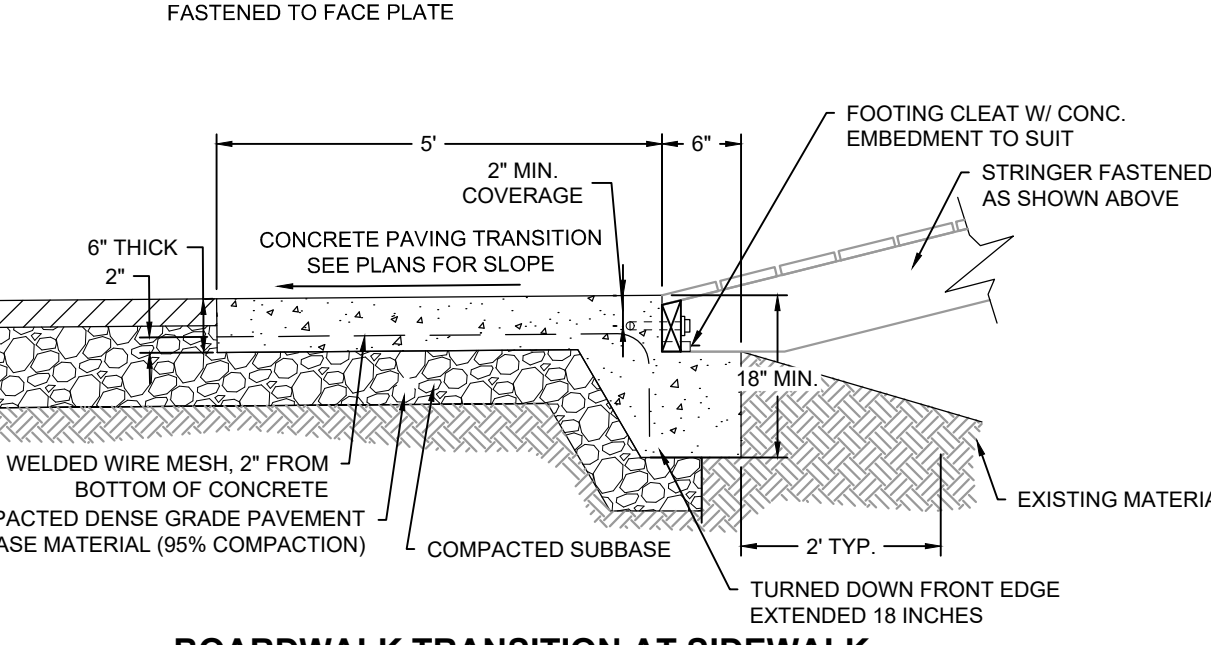
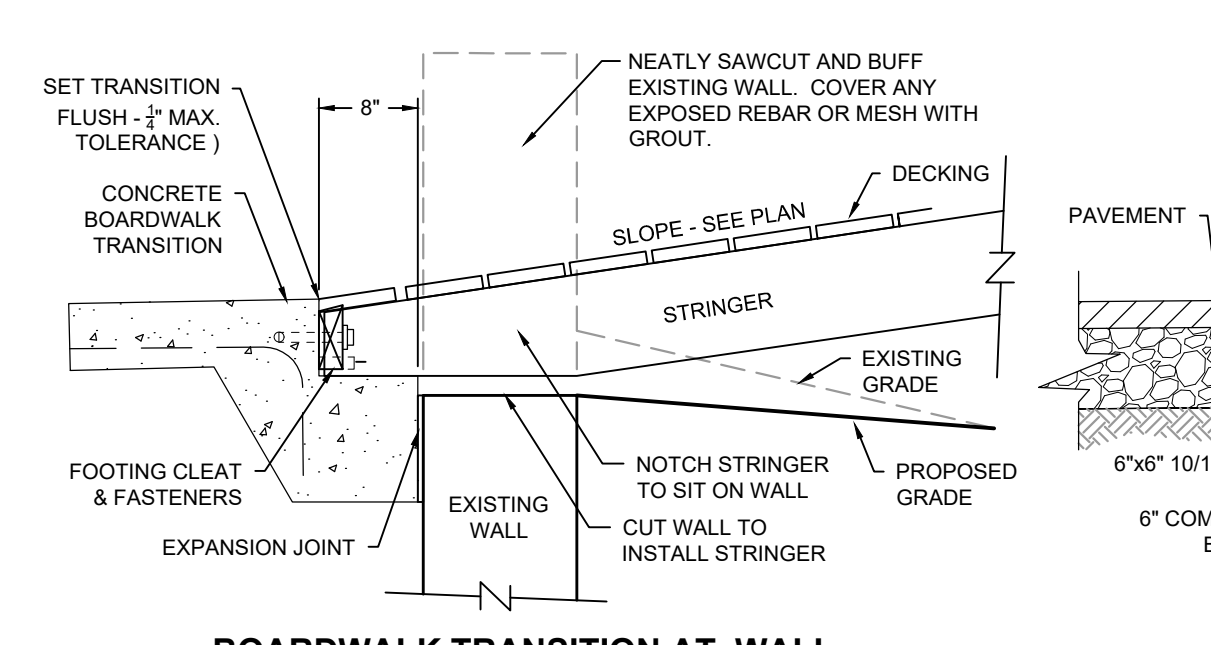
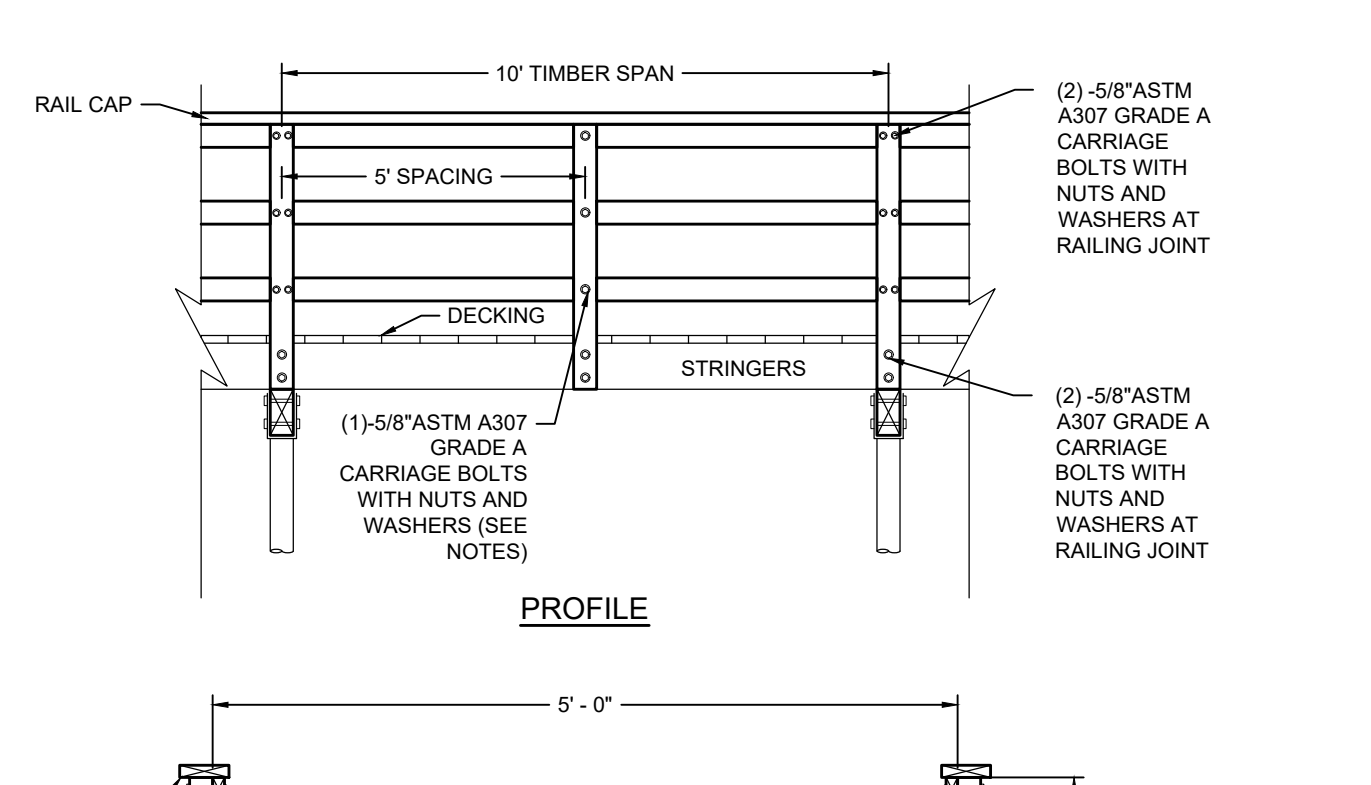
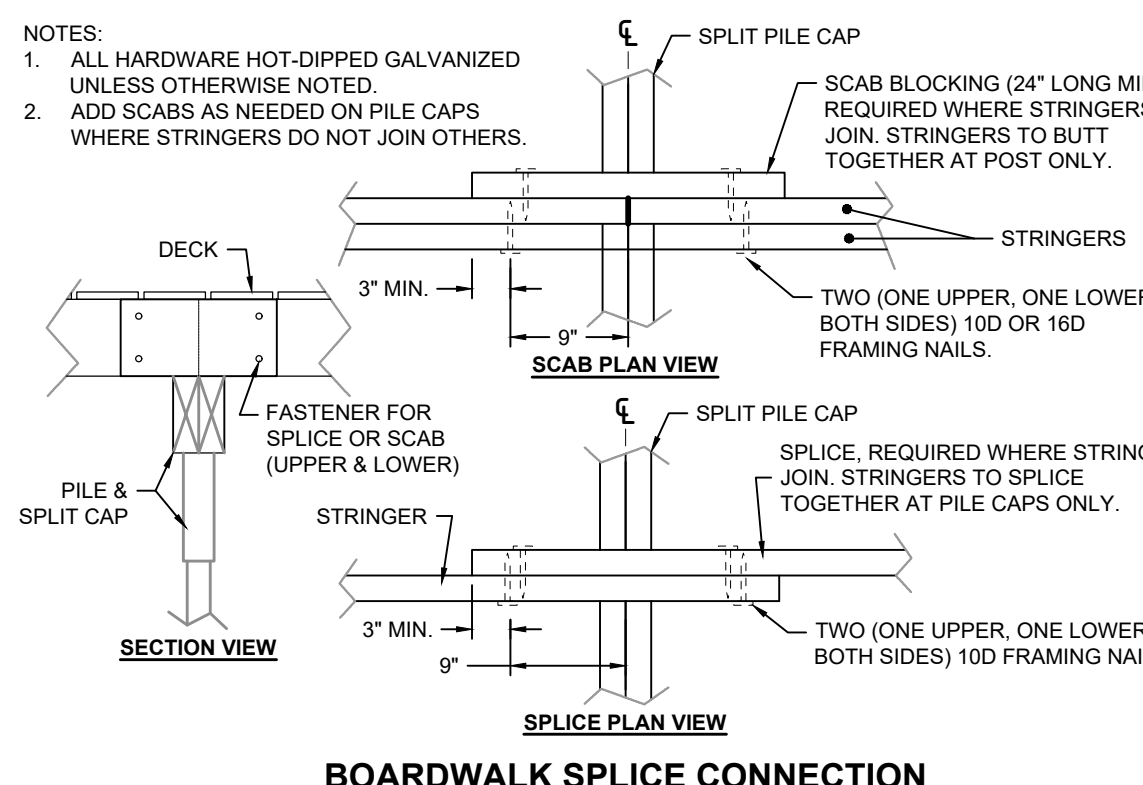
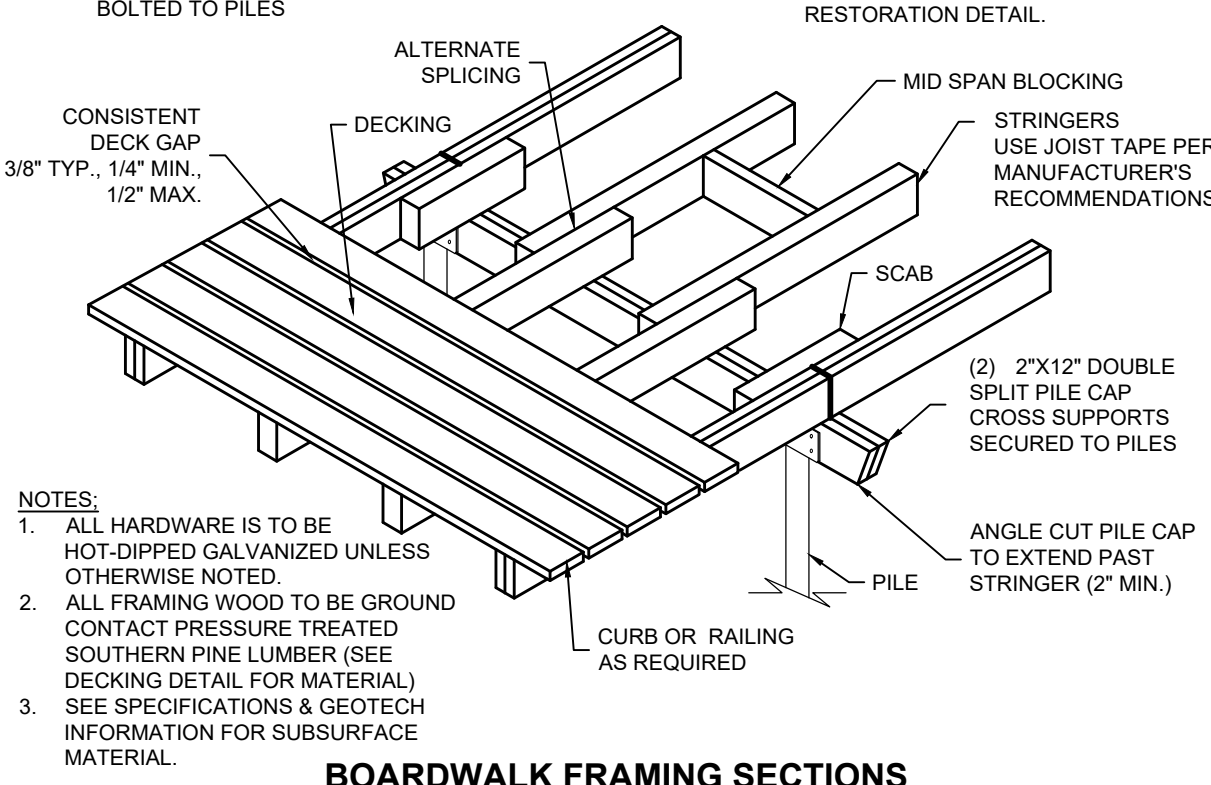
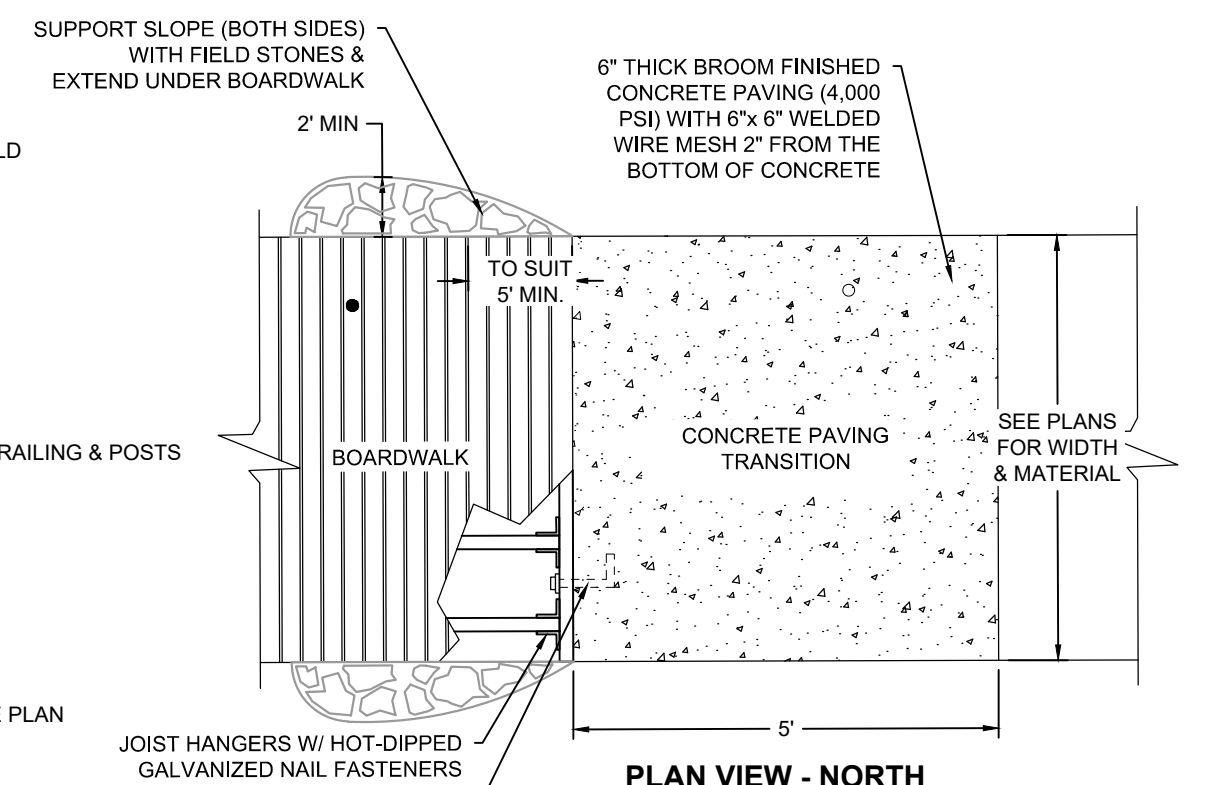
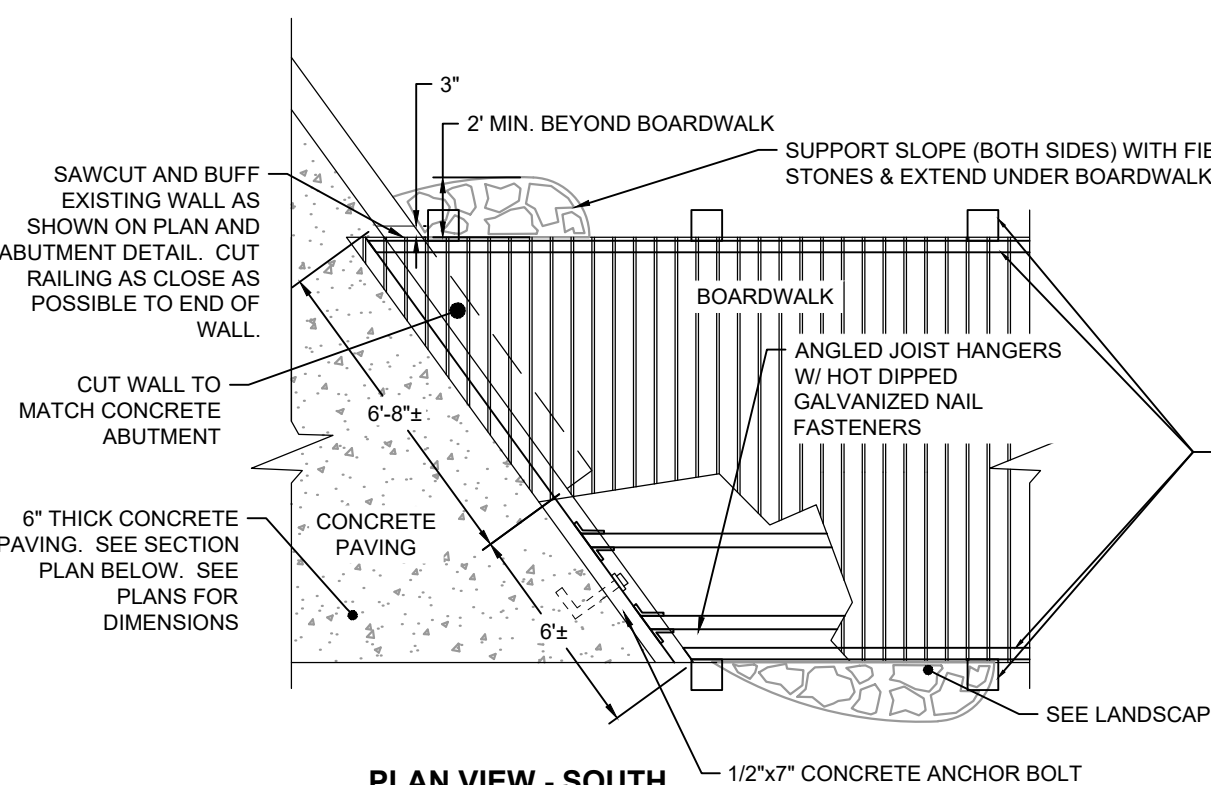

- NOTES:
- SLOPE DIRECTION VARIES. SEE PLANS FOR DIRECTION OF SLOPE.
 - CONCRETE TO BE 4,000 PSI.
 - CONCRETE CONSTRUCTION JOINTS TO BE SPACED AT 5' INTERVALS AS NEEDED.

CONCRETE BOARDWALK TRANSITION
NOT TO SCALE

- NOTES:
- DECKING MATERIAL TO BE 2" x 6" WESTERN RED CEDAR OR APPROVED EQUIVALENT.
 - DECK FASTENERS (SCREWS): #10 3" STAINLESS STEEL DECK SCREWS.
 - PRE-DRILL FASTENER ALL HOLES.
 - FASTENER STAGGERING AND DECK OVERHANG TO BE CONSISTENT FOR LENGTH OF BOARDWALK.
 - DECK GAPS - 3/8" TYP., 1/4" MIN., 1/2" MAX.

BOARDWALK DECKING
NOT TO SCALE

- NOTES:
- ALL HARDWARE HOT-DIPPED GALVANIZED OR STAINLESS STEEL.
 - BLOCKING SHALL BE LOCATED BETWEEN STRINGERS AND PROVIDED MID-SPAN BETWEEN PILE CAPS.
 - SOLID BLOCKING IS REQUIRED FROM STRINGER TO STRINGER ACROSS THE ENTIRE WIDTH OF THE DECK.
 - CONTRACTOR MAY SUBSTITUTE AN ENGINEER APPROVED EQUIVALENT HARDWARE TYPE.

STRINGER BLOCKING
NOT TO SCALE

- NOTE:
- RAILING AND POST WOOD: WESTERN RED CEDAR
 - ALL HARDWARE HOT DIPPED GALVANIZED.
 - ALL BOLTS WITH WASHERS AND NUTS.
 - RAILS AND RAIL CAP EITHER MOUNTED WITH POST BOLTS OR POST MUST BE BOLTED TO THE STRINGERS.
 - RAIL POST TO BE BOLTED THROUGH STRINGER AND SCAB WHERE APPLICABLE.

BOARDWALK RAILING
NOT TO SCALE

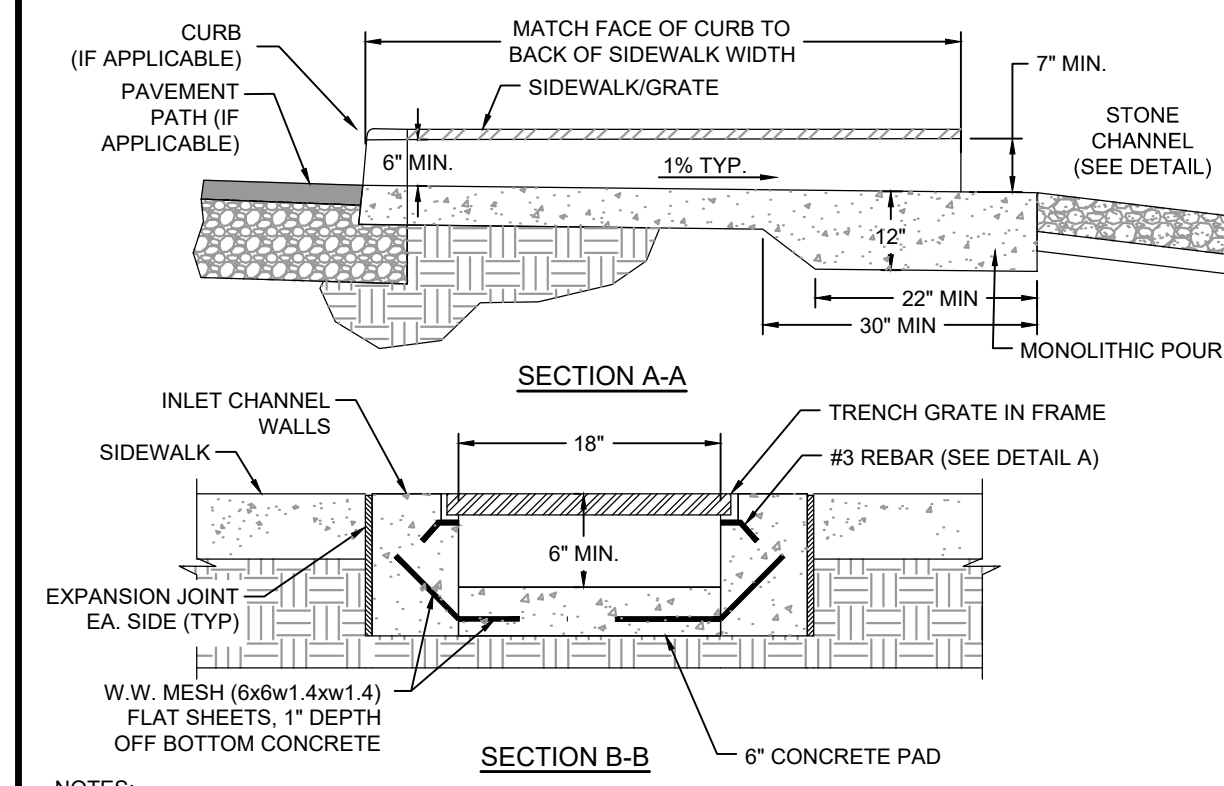
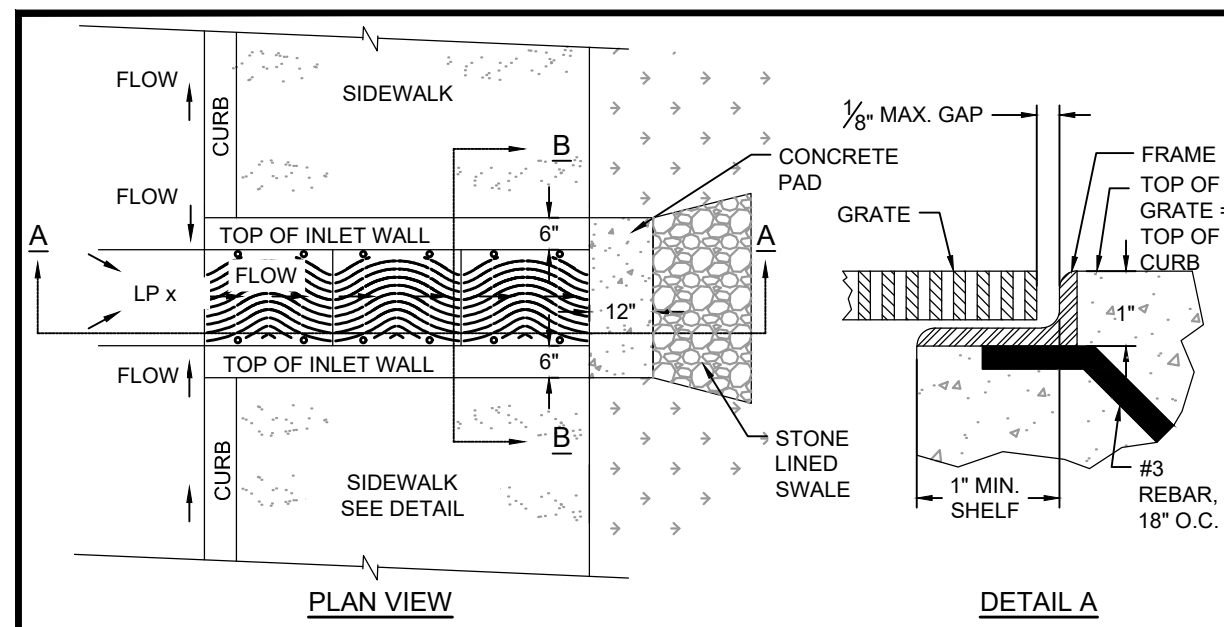

- NOTES:
1. TRENCH GRATE TO BE TITILE WAVE MODEL BY URBAN ACCESSORIES OR APPROVED EQUIVALENT. LOCAL DISTRIBUTOR IS FOX ASSOCIATES OF HOPE, MAINE (207-783-4410).
2. TRENCH GRATE SHALL BE INSTALLED PER MANUFACTURERS SPECIFICATIONS.
3. ALL TRENCH GRATES SHALL BE H-20 LOAD RATED.

SIDEWALK INLET GRATE
NOT TO SCALE

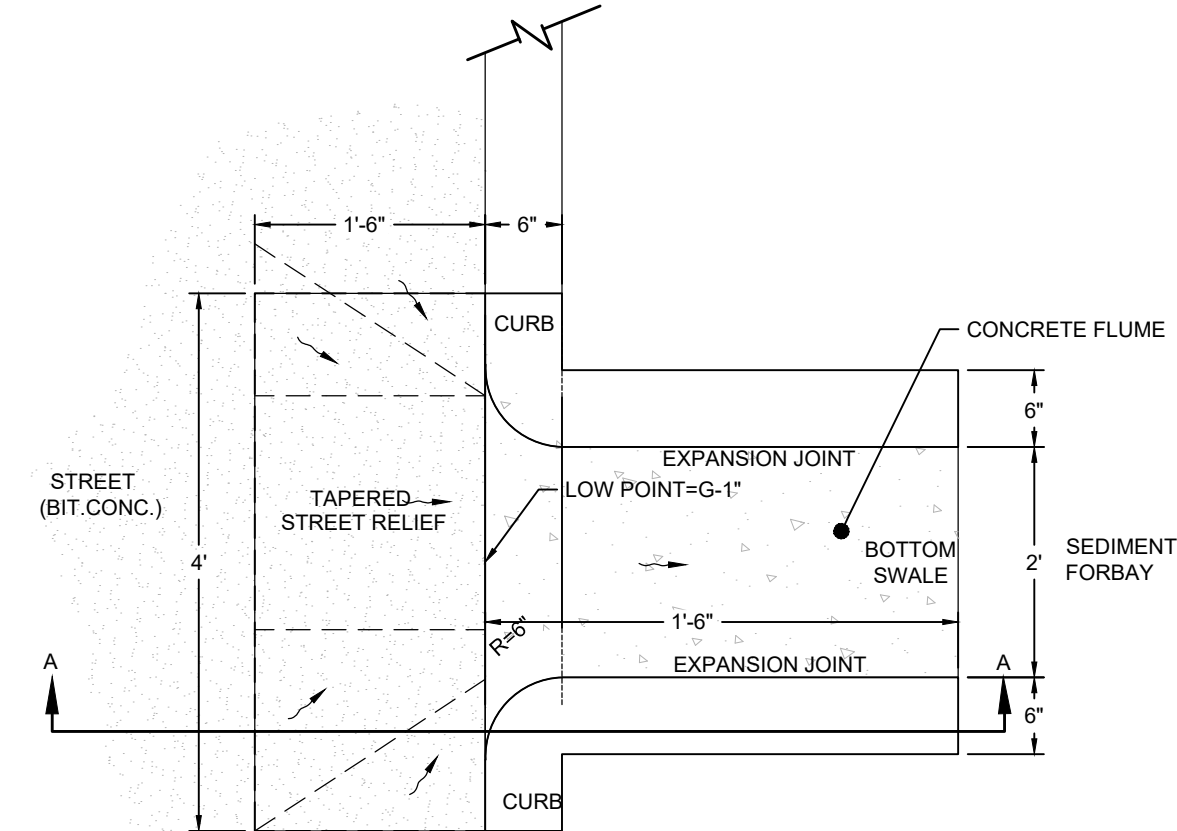
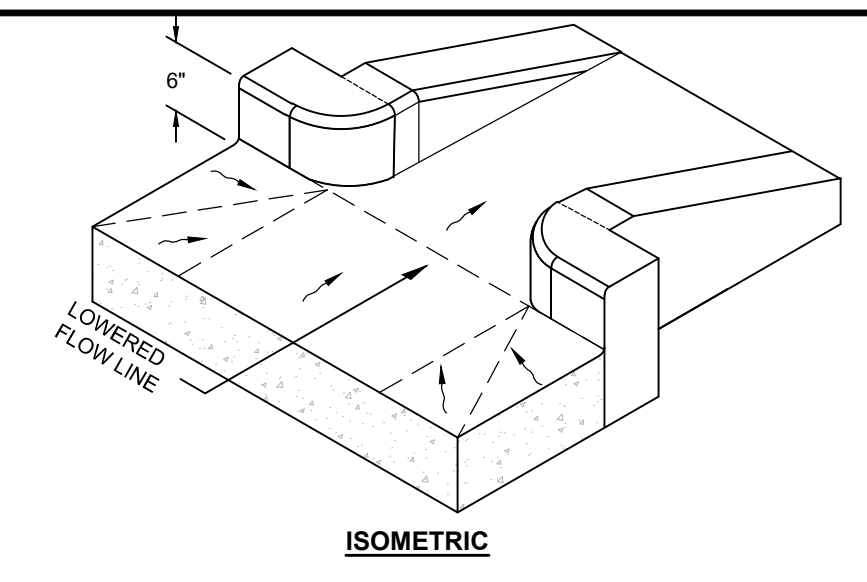

- NOTES:
1. DEPTH VARIES BY STORMWATER PRACTICE - SEE PLANS AND DETAILS.
2. SEE SEDIMENT FOREBAY DETAILS.

CURB INLET/OUTLET
NOT TO SCALE

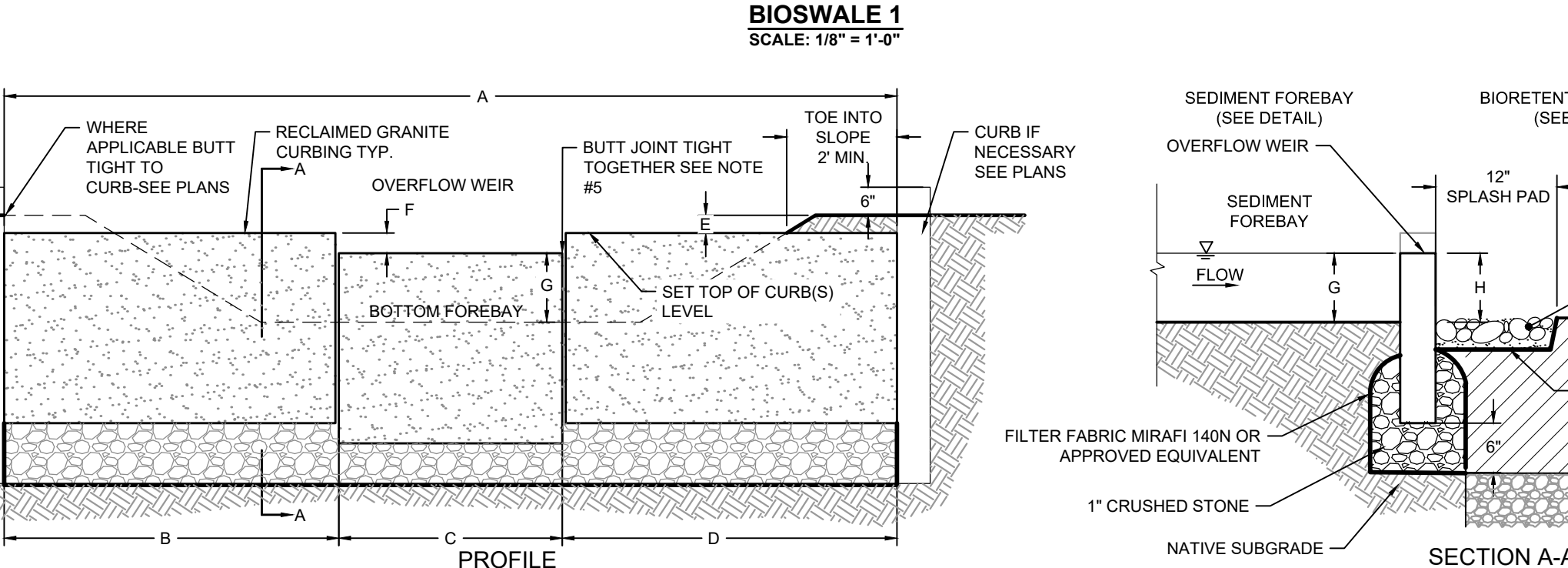
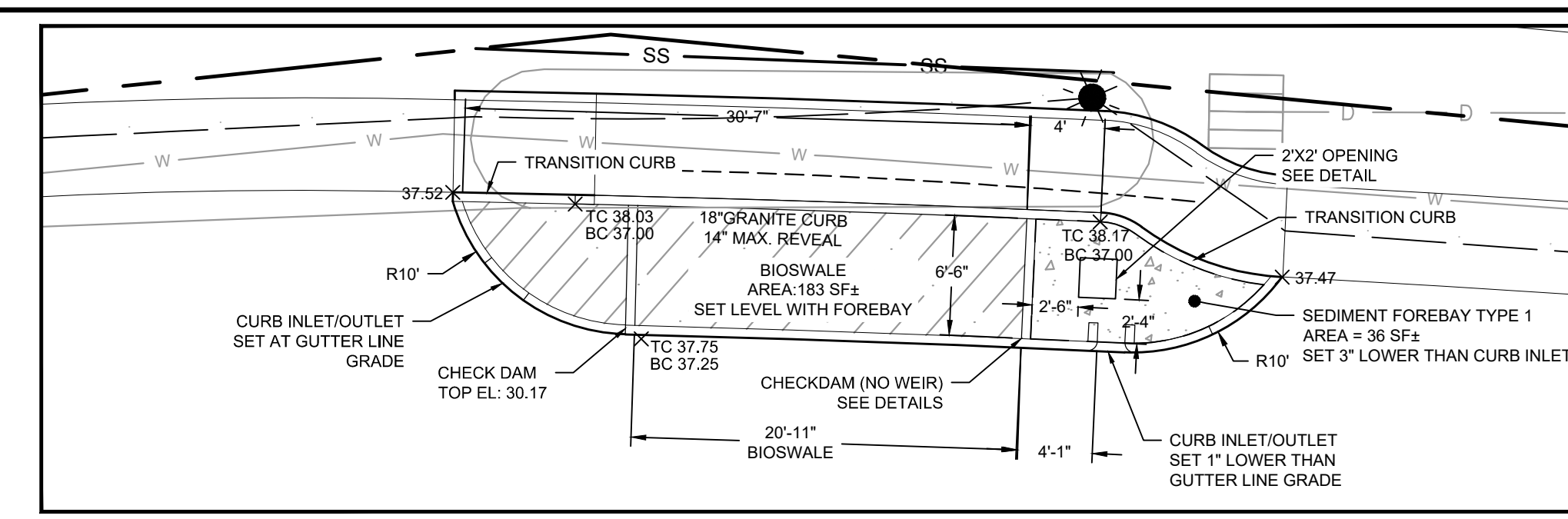

- NOTE:
1. KEY GRANITE CURBING INTO THE FOREBAY SIDE SLOPES OR BUTT TIGHTLY TO FACE OF GRANITE CURB. EXTEND A MINIMUM OF 2' TO PREVENT FLOW FROM DIVERTING THE CHECK DAM.
2. USE RECLAIMED OR RECYCLED GRANITE CURB I WHEN POSSIBLE. PROVIDE LENGTHS AND DIMENSIONS TO MATCH PLANS AND DETAILS.
3. GROUT ABUTTING SECTIONS OF GRANITE CURBING.
4. SEE PLANS AND SCHEDULE FOR CHECKDAM LENGTH, LAYOUT AND CONFIGURATION.
5. BUTT CURB JOINT TIGHT TOGETHER AND DO GROUT TO ALLOW FOR WEEPS.

BIOSWALE 1
SCALE: 1/8" = 1'-0"

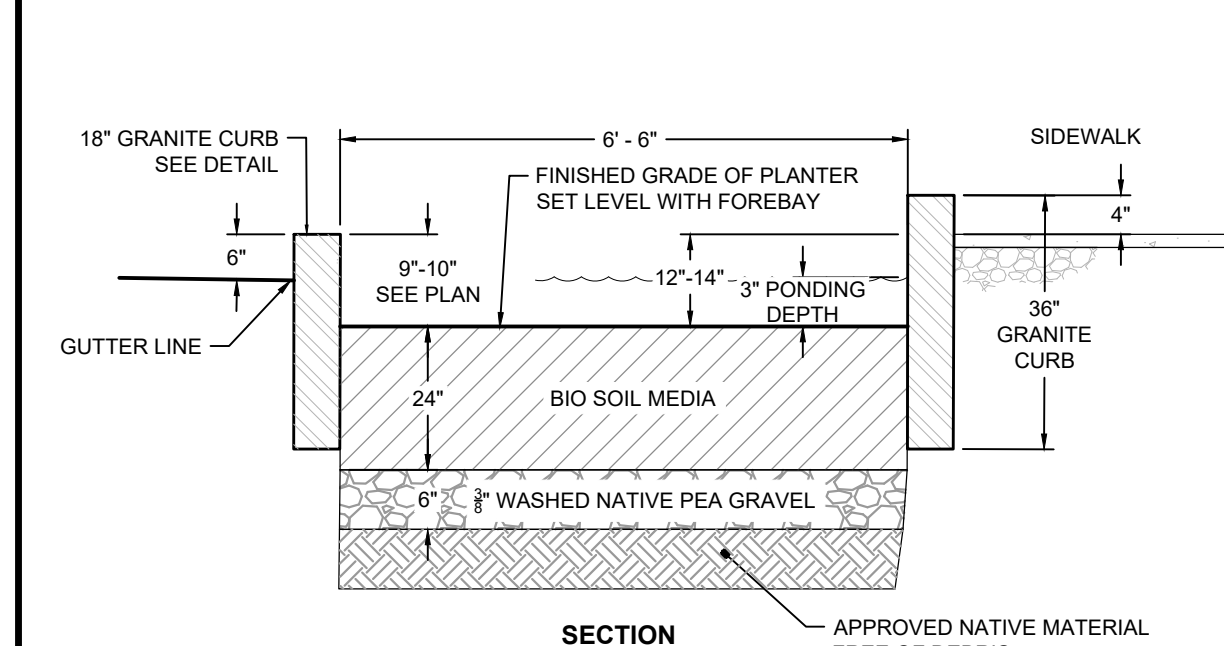

- NOTES:
1. LONGITUDINAL SLOPE: 0 TO 2% MAXIMUM.
2. CROSS SLOPE: 0%
3. SEE BIO SWALE SOIL AND PLANTING REQUIREMENTS.
4. SEE LANDSCAPE PLANS FOR PLANTING DETAILS.

BIOSWALE SECTION
NOT TO SCALE

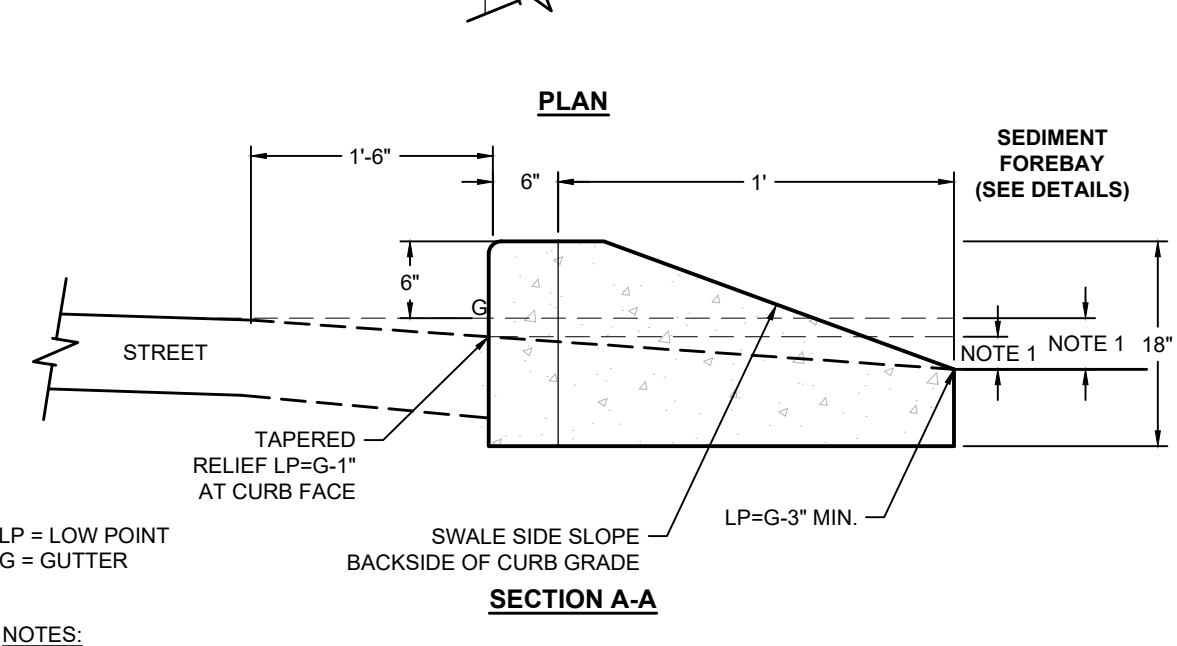

- NOTES:
1. DEPTH VARIES BY STORMWATER PRACTICE - SEE PLANS AND DETAILS.
2. SEE SEDIMENT FOREBAY DETAILS.

CURB INLET/OUTLET
NOT TO SCALE

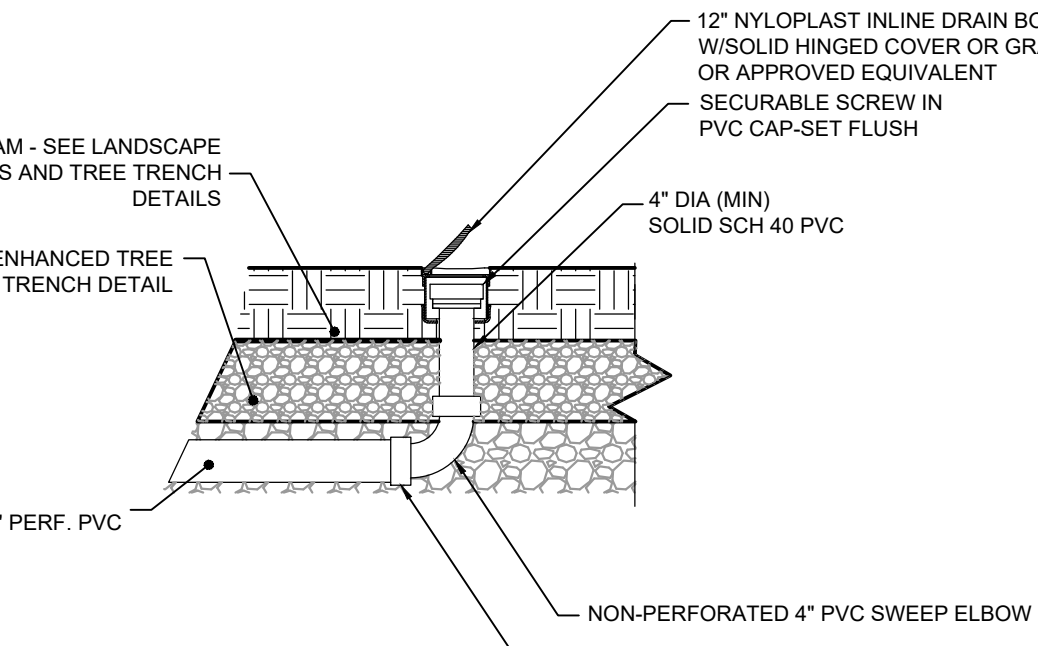

- NOTES:
1. DEPTH VARIES BY STORMWATER PRACTICE - SEE PLANS AND DETAILS.
2. SEE SEDIMENT FOREBAY DETAILS.

TREE TRENCH CLEANOUT
NOT TO SCALE

FOREBAY CHECKDAM SCHEDULE:

	Length A (ft - in)	Length B (ft)	Length C (ft)	Length D (ft)	Height E (inches)	Height F (inches)	Height G (inches)	Height H (inches)
BIO 1	12' - 10"	5'	2' - 10"	5'	0	3"	4"	4"
BIO 2	16'	6'	4'	6'	6"	3"	6"	4 3/4"
BIOSWALE 1	6'-6"				VARIES	0	2"	2"

ENHANCED TREE TRENCH SCHEDULE

Tree Trench #	Length (feet)	Width (feet)	Max. Depth (feet)	Stone Below Pipe (in)	Tree Pit Width (ft)	Tree Pit Length (ft)	Tree Pit Depth (ft)
1	45	7	5.32	12.00	4	4	3
2	50	4.58	5.28	12.00	3	4	3
3	109	7	4.80	6.00	4	4	3
4	54	4	5.10	6.00	3	4	3
5	80.5	7	4.82	6.00	4	4	3

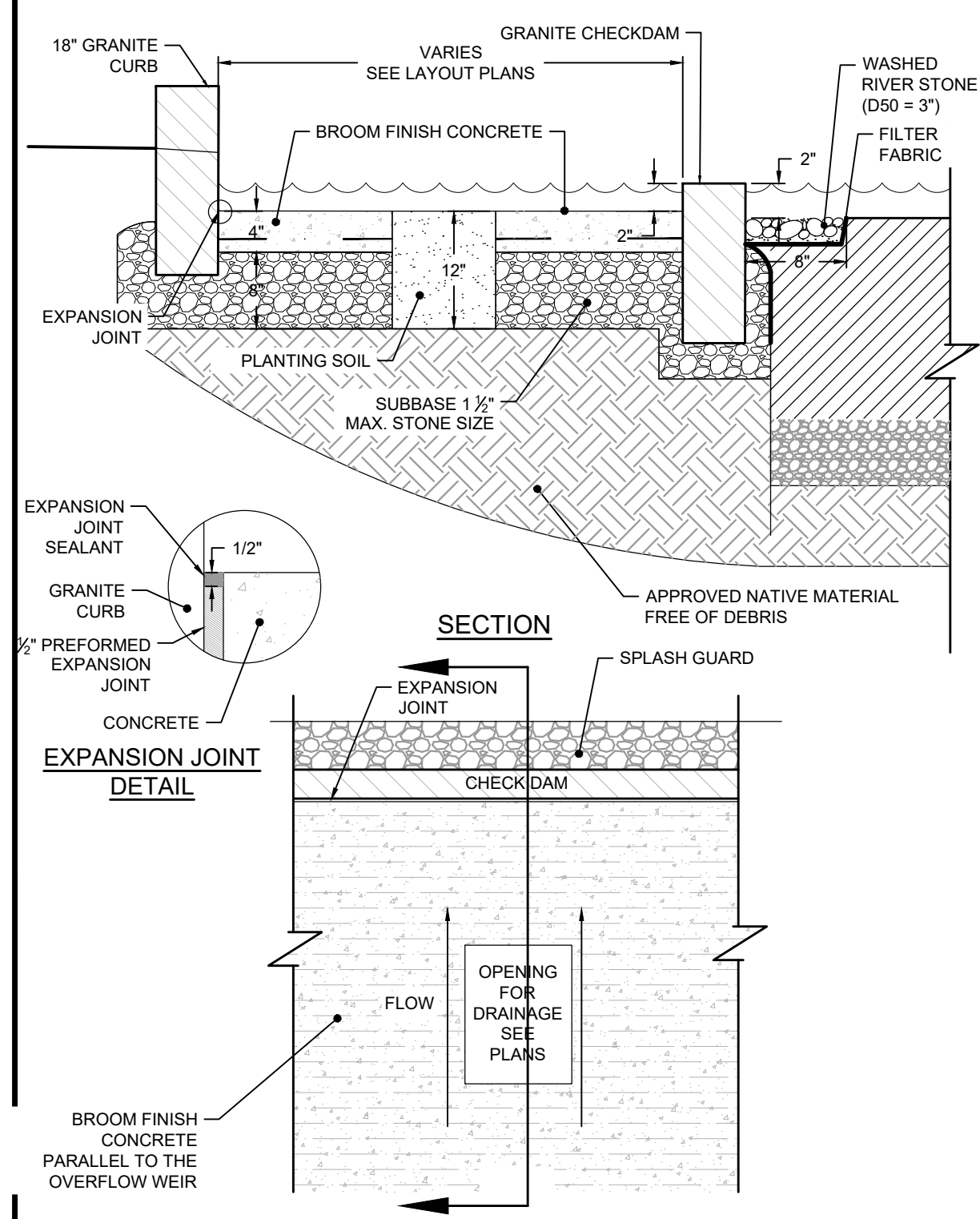

- NOTES:
1. CEMENT CONCRETE STRENGTH: 4,000 PSI-TYPE II
2. GRANITE CURB TO BE USED FOR ANY CHECK DAMS (SEE PLANS)

SEDIMENT FOREBAY TYPE X
NOT TO SCALE

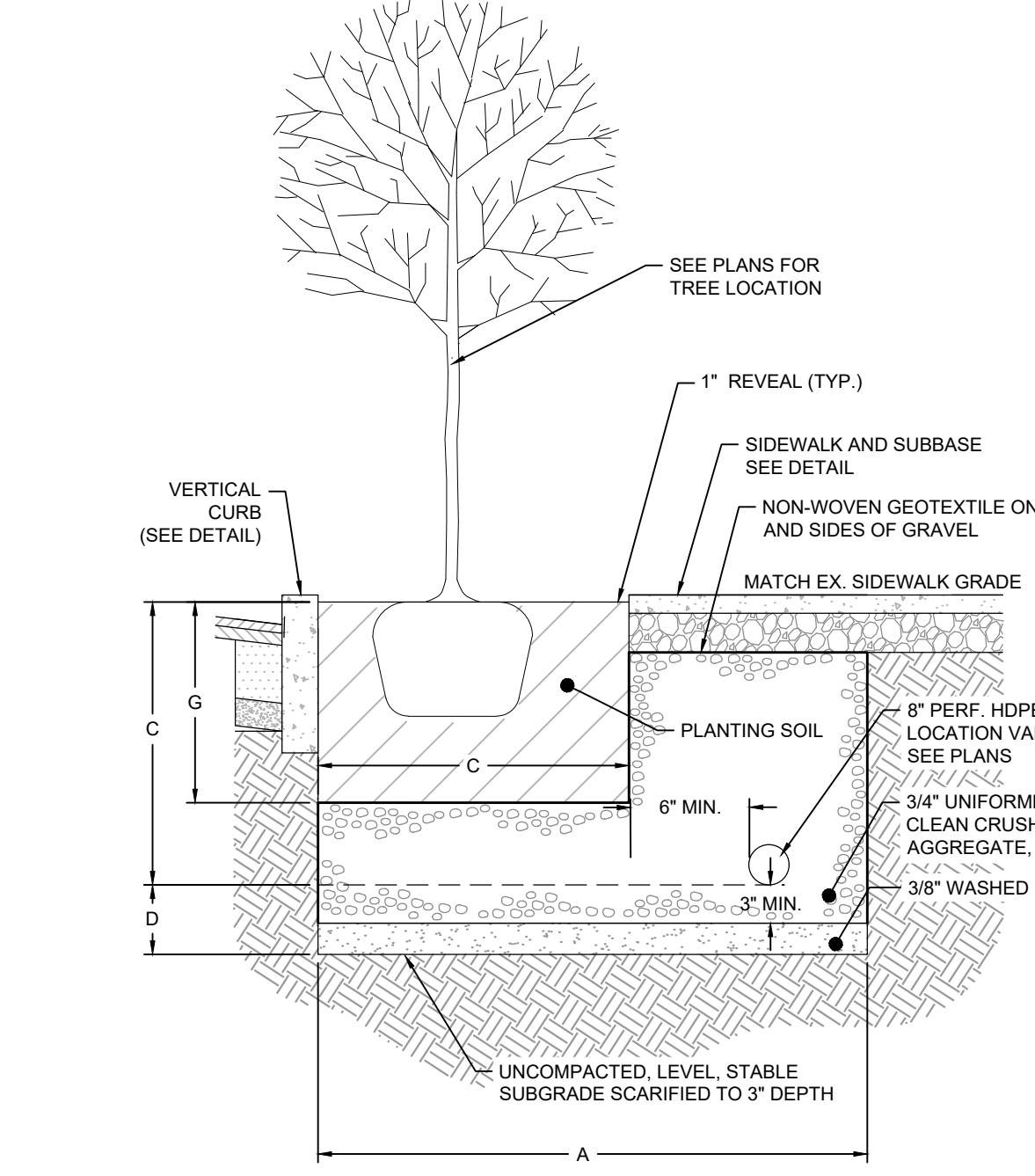

- NOTES:
1. PLANTING SOIL DEPTH VARIES BASED UPON TOP OF 3/4" GRAVEL AND EXISTING SIDEWALK GRADE.
2. 3/4" GRAVEL DEPTH VARIES BASED UPON INLET PIPE INVERT, PIPE SLOPE AND PIPE COVER REQUIREMENTS.

CROSS SECTION B-B'
NOT TO SCALE

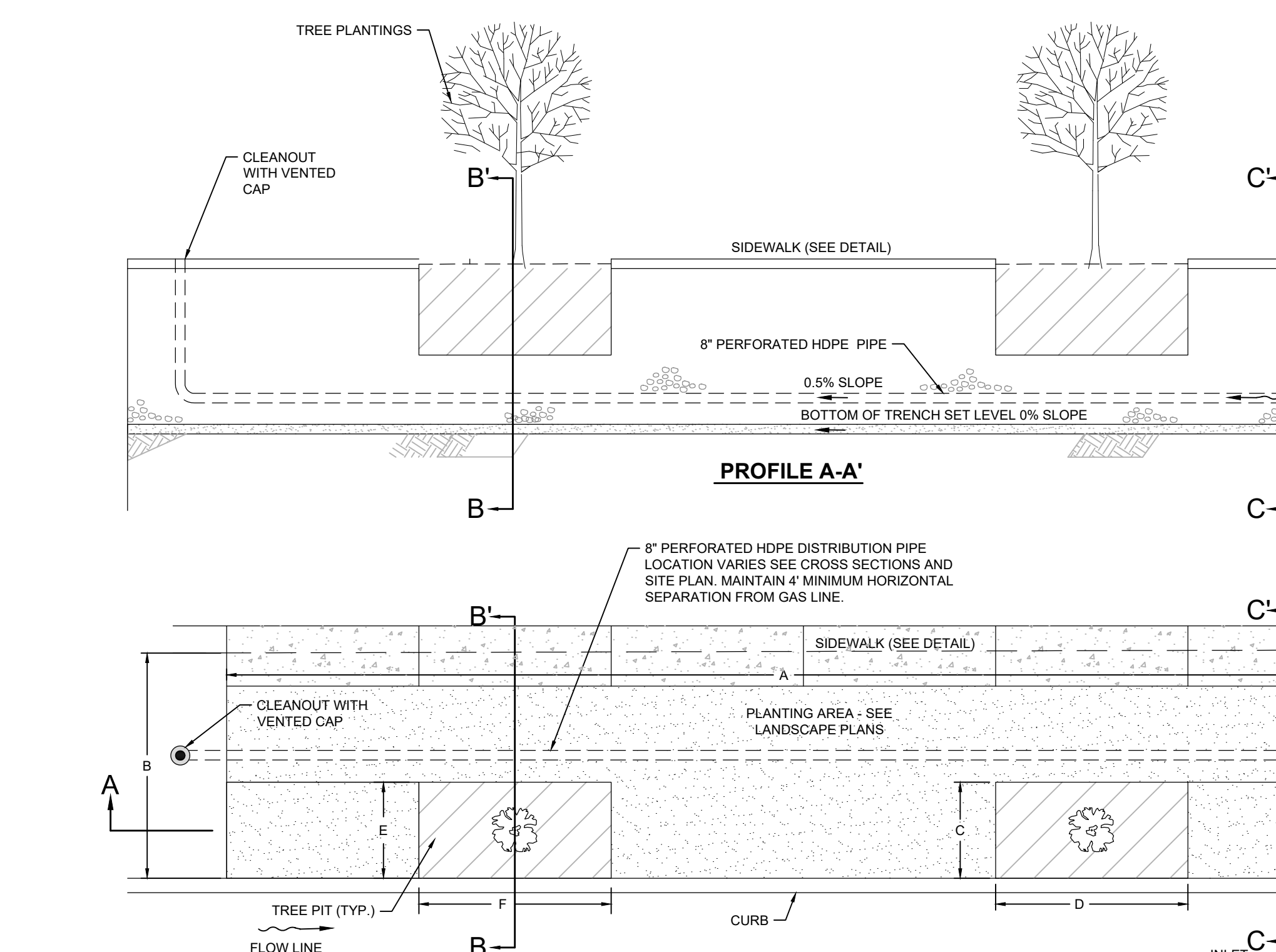

- NOTES:
1. PLANTING SOIL DEPTH VARIES BASED UPON TOP OF 3/4" GRAVEL AND EXISTING SIDEWALK GRADE.
2. 3/4" GRAVEL DEPTH VARIES BASED UPON INLET PIPE INVERT, PIPE SLOPE AND PIPE COVER REQUIREMENTS.

ENHANCED STORMWATER TREE TRENCH PLAN
NOT TO SCALE

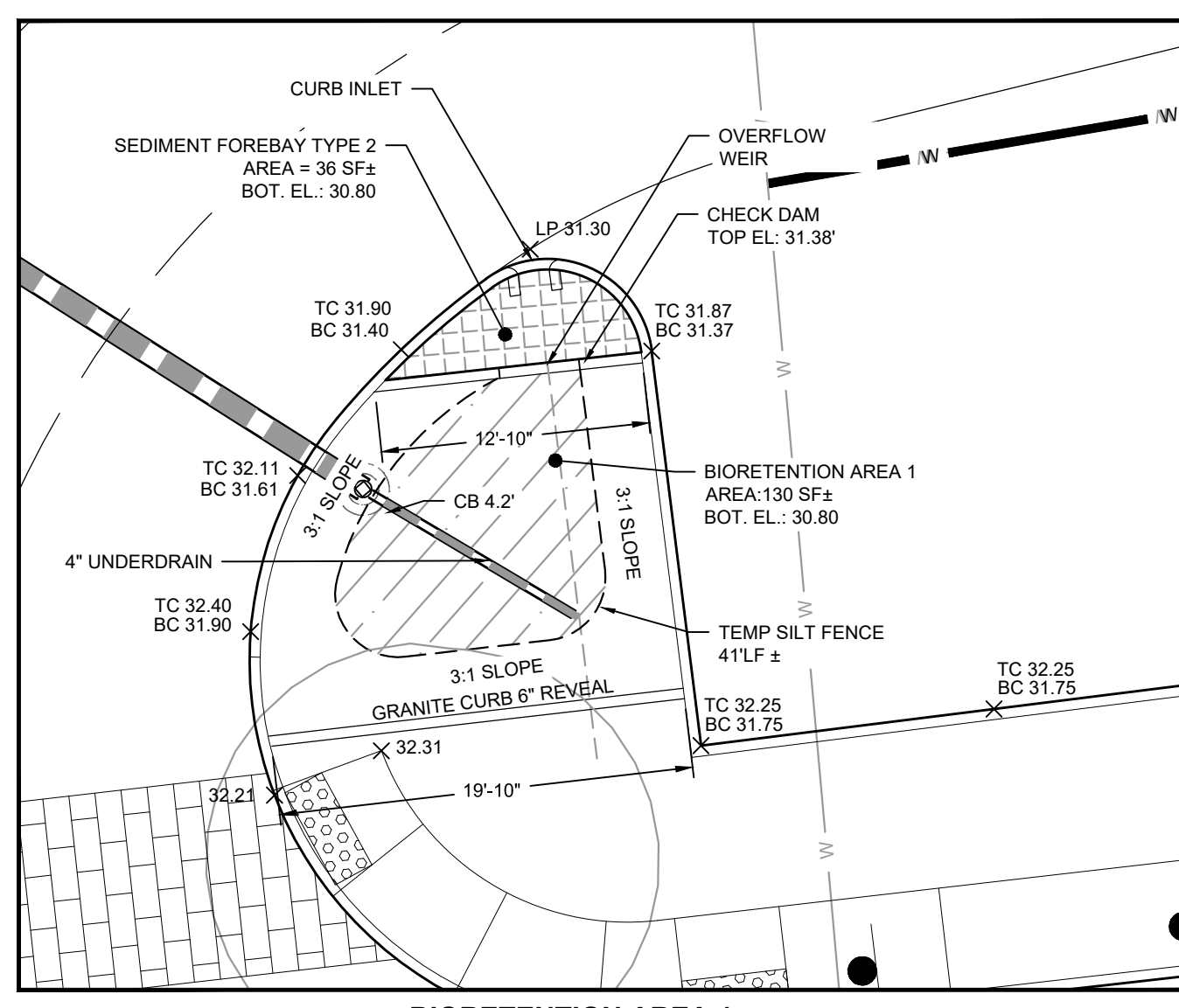

BIORETENTION AREA 1
SCALE: 1/8" = 1'-0"

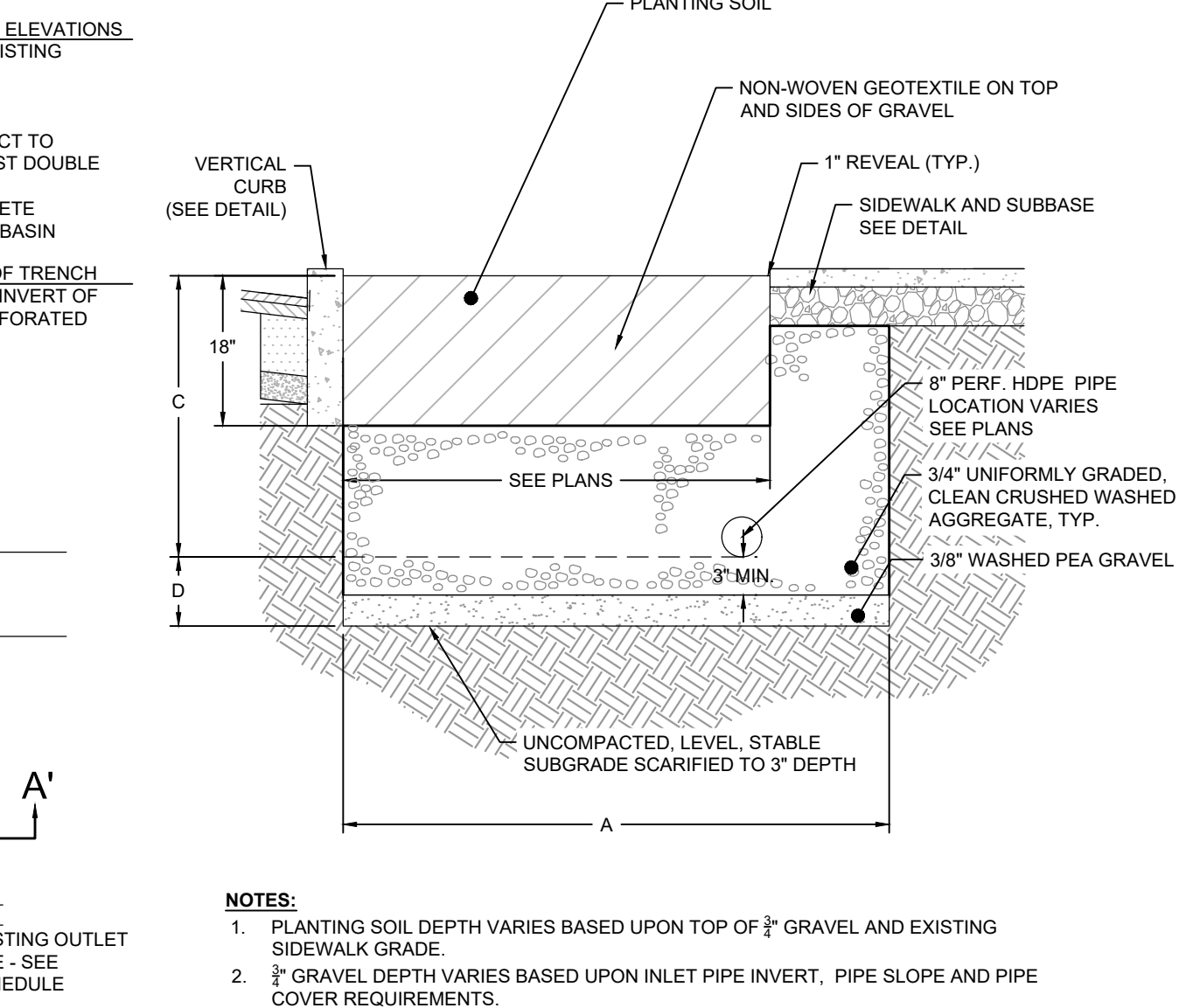

- NOTES:
1. PLANTING SOIL DEPTH VARIES BASED UPON TOP OF 3/4" GRAVEL AND EXISTING SIDEWALK GRADE.
2. 3/4" GRAVEL DEPTH VARIES BASED UPON INLET PIPE INVERT, PIPE SLOPE AND PIPE COVER REQUIREMENTS.

CROSS SECTION C-C'
NOT TO SCALE

**BARNSTABLE
MARSTONS MILLS VILLAGE CENTER IMPROVEMENTS**

SHEET NO.	TOTAL SHEETS
13	108

**CONSTRUCTION DETAILS-DRAINAGE & UTILITIES (2)
SHEET 9 OF 10**

19-Oct-2018
last modified: 10/19/18
printed: 10/19/18 by gg
13024-DE.DOT.DWG

BIORETENTION CONSTRUCTION SEQUENCE
THE FOLLOWING CONSTRUCTION SEQUENCE IS TO BE USED AS A GENERAL GUIDELINE. COORDINATE WITH THE OWNER, ENGINEERS, AND LANDSCAPE ARCHITECTS AND SUBMIT A PROPOSED CONSTRUCTION SEQUENCE FOR REVIEW AND APPROVAL PRIOR TO CONSTRUCTION.

- CONDUCT A PRE-CONSTRUCTION MEETING.
- CHECK FOR EXISTING UTILITIES PRIOR TO ANY EXCAVATION.
- CLEAR AND GRUB THE PROPOSED BIORETENTION AREA.
- ROUGH GRADE THE BIORETENTION AREA DURING GENERAL CONSTRUCTION.
- EXCAVATE PRETREATMENT CELLS AND/OR SEDIMENT FOREBAYS PRIOR TO BIORETENTION CONSTRUCTION.
- DO NOT CONSTRUCT THE BIORETENTION AREA UNTIL ALL DISTURBED AREAS WITHIN THE CONTRIBUTING DRAINAGE AREAS HAVE BEEN GRADED AND STABILIZED.
- INSTALL TEMPORARY EROSION AND SEDIMENT CONTROLS TO DIVERT STORMWATER AWAY FROM THE BIORETENTION AREA.
- EXCAVATE THE BIORETENTION FACILITY TO THE BOTTOM INVERT OF THE SUBDRAIN SYSTEM. IF USED FOR TEMPORARY STORMWATER MANAGEMENT DURING CONSTRUCTION PROVIDE A SURFACE ELEVATION AT A MINIMUM 1-FOOT ABOVE THE BOTTOM OF UNDERDRAIN ELEVATION AS SHOWN IN THE BIORETENTION SCHEDULE. THIS ALLOWS FOR AN OVER-DIG OF THE ACCUMULATED SEDIMENT FROM WITHIN THE BIORETENTION AREA PRIOR TO MEDIA/FABRIC INSTALLATION.
- PRIOR TO THE INSTALLATION OF FILTER FABRIC AND MEDIA WITHIN THE BIORETENTION AREAS, REMOVE AND PROPERLY DISPOSE OF SEDIMENT ACCUMULATED IN ANY PARTIALLY CONSTRUCTED OR TEMPORARY BIORETENTION/DRAINAGE AREA USED FOR SEDIMENT CONTROL DURING CONSTRUCTION.
- MANDATORY NOTIFICATION/APPROVAL OF THE PROJECT ENGINEER IS REQUIRED PRIOR TO PROCEEDING WITH NEXT STAGE. CALL THE ENGINEER (HORSLEY WITTEN GROUP, INC.) AT 508-833-8600 PRIOR TO 12:00 NOON THE PRECEDING DAY TO ARRANGE FOR ANY REQUESTED FIELD VISITS.
- INSTALL THE FILTER FABRIC ALONG THE EXCAVATION SIDE WALLS. ENGINEER FIELD VISIT AND REPORT REQUIRED SEE NOTE 10.
- RIIP THE BOTTOM SOILS TO A DEPTH OF SIX INCHES TO PROMOTE GREATER INFILTRATION.
- INSTALL THE OVERFLOW OUTLET STRUCTURE AS SPECIFIED IN THE DRAWINGS.
- INSTALL UNDERDRAIN AS INDICATED ON DRAWINGS. ENGINEER FIELD VISIT AND REPORT REQUIRED PRIOR TO COVERING THE UNDERDRAIN. SEE NOTE 10.
- INSTALL PEA GRAVEL LAYER AS INDICATED ON DRAWINGS.
- DELIVER APPROVED BIORETENTION SOIL AND STORE ON ADJACENT IMPERVIOUS AREA OR PLASTIC SHEETING.
- BACKFILL WITH APPROVED BIORETENTION SOIL TO THE DESIGN GRADE (UN-COMPACTED) AS INDICATED ON DRAWINGS. THE CONTRACTOR MUST SUBMIT A SOIL SAMPLE (2 LBS) TO THE ENGINEER PRIOR TO SOIL DELIVERY TO THE SITE.
- STABILIZE ALL REMAINING DISTURBED AREAS AND SIDE SLOPES WITH SEEDING, HYDROSEEDING, AND/OR EROSION CONTROL BLANKETS AS INDICATED ON DRAWINGS. ENGINEER FIELD VISIT AND REPORT REQUIRED SEE NOTE 10.
- INSTALL BIORETENTION PLANTINGS AS INDICATED ON DRAWINGS. DO NOT PLANT BEFORE THE REMAINING DISTURBED AREAS SURROUNDING THE FACILITY ARE STABILIZED.
- INSTALL MULCH LAYER AS INDICATED ON DRAWINGS. THE CONTRACTOR MUST SUBMIT A MULCH SAMPLE (1 GALLON) TO THE ENGINEER PRIOR TO DELIVERY TO THE SITE.
- CONDUCT FINAL CONSTRUCTION INSPECTION WITH ENGINEER. ENGINEER FIELD VISIT AND REPORT REQUIRED SEE NOTE 10 BELOW.
- REMOVE REMAINING EROSION AND SEDIMENT CONTROLS ONLY AFTER SURROUNDING DISTURBED AREAS HAVE BEEN PROPERLY STABILIZED.

CONSTRUCTION NOTES

- EXAMINATION**
 - VERIFY LAYOUT AND ORIENTATION OF BIORETENTION AREA AND CONNECTIONS.
 - VERIFY EXCAVATION BASE IS READY TO RECEIVE WORK AND EXCAVATIONS, DIMENSIONS, AND ELEVATIONS ARE AS INDICATED ON DRAWINGS.
- PREPARATION**
 - CALL DIGSAFE AT 1-888-DIG-SAFE (1-888-344-7233) NOT LESS THAN THREE BUSINESS DAYS BEFORE PERFORMING WORK.
 - REQUEST UNDERGROUND UTILITIES TO BE LOCATED AND MARKED WITHIN AND SURROUNDING CONSTRUCTION AREAS.
 - IDENTIFY REQUIRED LINES, LEVELS, CONTOURS, AND DATUM.
 - CLEAR AND GRUB THE PROPOSED BIORETENTION AREA.
- EXCAVATION**
 - EXCAVATE BIORETENTION AREA IN ACCORDANCE WITH GENERAL NOTES AND SPECIFICATIONS.
 - TO MINIMIZE COMPACTION, WORK EXCAVATORS OR BACKHOES FROM THE SIDES TO EXCAVATE THE BIORETENTION AREA TO ITS APPROPRIATE DESIGN DEPTH AND DIMENSIONS. USE EXCAVATING EQUIPMENT WITH ADEQUATE REACH SO THEY DO NOT WORK IN THE FOOTPRINT OF THE BIORETENTION AREA. IF APPLICABLE AND PER THE ENGINEER'S DIRECTION USE A CELL CONSTRUCTION APPROACH IN LARGER BIORETENTION BASINS, WHEREBY THE BASIN IS SPLIT INTO 500 TO 1000 SQUARE FOOT TEMPORARY CELLS WITH A 10 TO 15 FOOT EARTH BRIDGE IN BETWEEN, SO THAT CELLS CAN BE EXCAVATED FROM THE SIDE.
 - EXCAVATE AND SEAL ANY PRETREATMENT CELLS AND/OR SEDIMENT FOREBAYS FIRST AND SEALED TO TRAP SEDIMENTS PER THE DRAWINGS.
 - ROUGH GRADE THE BIORETENTION AREA DURING GENERAL CONSTRUCTION. EXCAVATE THE BIORETENTION FACILITIES TO WITHIN 1 FOOT OF UNDERDRAIN BOTTOM.
 - IF THE BIORETENTION AREA IS TO BE USED AS A TEMPORARY DRAINAGE STORAGE BASIN DURING THE EARLY STAGES OF PROJECT CONSTRUCTION, THE SIDE SLOPES SHOULD BE TEMPORARILY STABILIZED AND SILT FENCE INSTALLED ALONG THE TOE OF THE ROUGH GRADED BIORETENTION SLOPES TO MINIMIZE EXCESSIVE SEDIMENTATION OF THE BIORETENTION FLOOR.
- COMPACTION**
 - MINIMIZE COMPACTION OF BOTH THE BASE OF THE BIORETENTION AREA AND THE REQUIRED BACKFILL. COMPACTION WILL SIGNIFICANTLY CONTRIBUTE TO DESIGN FAILURE.
 - USE EXCAVATOR OR BACKHOES TO EXCAVATE THE BIORETENTION AREA.
 - IF THE BIORETENTION AREA IS EXCAVATED USING A LOADER, USE ONLY WIDE TRACK OR MARSH TRACK EQUIPMENT, OR LIGHT EQUIPMENT WITH TURF TIRE TIRES. USE OF EQUIPMENT WITH NARROW TRACKS OR NARROW TIRES, RUBBER TIRES WITH LARGE LUGS, OR HIGH PRESSURE TIRES CAUSE EXCESSIVE COMPACTION RESULTING IN REDUCED INFILTRATION RATES AND STORAGE VOLUMES AND IS NOT ACCEPTABLE.
 - COMPACTION CAN BE ALLEVIATED AT THE BASE OF THE BIORETENTION FACILITY BY USING A PRIMARY TILLING OPERATION SUCH AS A CHISEL PLOW, RIPPER, OR SUBSOILER. THESE TILLING OPERATIONS ARE PERFORMED TO REFRACTURE THE SOIL PROFILE THROUGH THE 12-IN COMPACTION ZONE. SUBSTITUTE METHODS MUST BE APPROVED BY THE ENGINEER. ROTOILLERS TYPICALLY DO NOT TILL DEEP ENOUGH TO REDUCE THE EFFECTS OF COMPACTION FROM HEAVY EQUIPMENT.
 - DO NOT COMPACT BIORETENTION SOIL WITH MECHANICAL EQUIPMENT.
- EMBANKMENT/BERM FILL**
 - CONSTRUCT EMBANKMENT/BERM IN ACCORDANCE WITH SPECIFICATIONS AND AS INDICATED ON DRAWINGS.
- INSTALLATION**
 - DO NOT CONSTRUCT THE BIORETENTION AREA UNTIL ALL DISTURBED AREAS WITHIN THE CONTRIBUTING DRAINAGE AREAS HAVE BEEN GRADED AND STABILIZED.
 - REMOVE SEDIMENT ACCUMULATED ALONG THE EXCAVATION FLOOR DURING SITE CONSTRUCTION PRIOR TO CONTINUING WITH THE BIORETENTION FACILITY CONSTRUCTION.
 - FORM BOTTOM OF EXCAVATION TO CORRECT ELEVATION.
 - IF INFILTRATION IS PROMOTED, THEN RIP THE BOTTOM SOILS TO A DEPTH OF SIX INCHES TO PROMOTE GREATER INFILTRATION.
 - INSTALL THE FILTER FABRIC ALONG THE EXCAVATION SIDE WALLS AS SPECIFIED IN THE DRAWINGS. IF FILTER FABRIC IS TO BE INSTALLED PLACE THE FILTER FABRIC ON THE SIDES OF THE BIORETENTION AREA WITH A MINIMUM SIX INCH OVERLAP AT ALL JOINTS.
 - INSTALL ANY TEMPORARY EROSION AND SEDIMENT CONTROLS TO DIVERT STORMWATER AWAY FROM THE BIORETENTION AREA DURING FINAL CONSTRUCTION AND UNTIL IT IS COMPLETED. SPECIAL PROTECTION MEASURES SUCH AS EROSION CONTROL FABRICS MAY BE NEEDED TO PROTECT VULNERABLE SIDE SLOPES FROM EROSION DURING THE CONSTRUCTION PROCESS.
 - ESTABLISH ELEVATIONS AND PIPE INVERTS FOR INLETS AND OUTLETS AS INDICATED ON DRAWINGS.
 - INSTALL THE OVERFLOW OUTLET STRUCTURE AS INDICATED ON DRAWINGS.
 - INSTALL UNDERDRAIN, INCLUDING 4 INCH PERFORATED PIPE, GRAVEL AND FILTER FABRIC ON TOP OF THE UNDERDRAIN GRAVEL AS INDICATED ON DRAWINGS. PLACE GRAVEL AROUND THE UNDERDRAIN PIPE AS INDICATED IN THE DETAILS. OBSERVATION WELLS AND/OR CLEAN-OUT PIPES MUST BE PROVIDED (SEE PLANS FOR LOCATION).
 - INSTALL PEA GRAVEL LAYER AS INDICATED ON DRAWINGS.
 - DELIVER APPROVED BIORETENTION SOIL AND STORE ON ADJACENT IMPERVIOUS AREA OR PLASTIC SHEETING.
- BACKFILLING**
 - BACKFILL WITH APPROVED BIORETENTION SOIL TO THE DESIGN GRADE AS SPECIFIED IN THE DRAWINGS.
 - PLACE SOIL IN 12 INCH LIFTS UNTIL DESIRED TOP ELEVATION OF BIORETENTION SOIL IS ACHIEVED. DO

- DO NOT COMPACT BIORETENTION SOIL WITH MECHANICAL EQUIPMENT.
 - GRADE BIORETENTION MATERIALS WITH LIGHT EQUIPMENT SUCH AS A COMPACT LOADER OR A DOZER/LOADER WITH MARSH TRACKS.
 - STABILIZE ALL REMAINING DISTURBED AREAS AND SIDE SLOPES WITH SEEDING, HYDROSEEDING, AND/OR EROSION CONTROL BLANKETS AS INDICATED ON DRAWINGS.
- PLANTING**
 - PLANT BIORETENTION AREA IN ACCORDANCE WITH PLANTING PLANS AND SPECIFICATIONS.
 - THE PRIMARY FUNCTION OF THE BIORETENTION STRUCTURE IS TO IMPROVE WATER QUALITY. DO NOT ADD FERTILIZERS OR OTHER SOIL AMENDMENTS TO THE BIORETENTION SOILS UNLESS INSTRUCTED BY THE ENGINEER. THE PLANTING SOIL SPECIFICATIONS PROVIDE ENOUGH ORGANIC MATERIAL TO ADEQUATELY SUPPLY NUTRIENTS FROM NATURAL CYCLING.
 - INSTALL BIORETENTION PLANTINGS AS INDICATED ON DRAWINGS. WATER DURING WEEKS OF NO RAIN FOR THE FIRST TWO MONTHS.
 - DO NOT PLANT BEFORE THE REMAINING DISTURBED AREAS SURROUNDING THE FACILITY ARE STABILIZED.
 - REMOVE SEDIMENT ACCUMULATED IN THE BIORETENTION AREA DURING THE PLANTING PHASE.
 - IF SUITABLE VEGETATIVE COVER HAS NOT BEEN ESTABLISHED ALONG THE BIORETENTION SIDE SLOPES PRIOR TO PLANTING, INSTALL A SILT FENCE PERIMETER AT THE TOE OF THE BIORETENTION SLOPES AND LEAVE IN PLACE UNTIL AN APPROVED VEGETATIVE COVER HAS BEEN ESTABLISHED.
 - INSTALL MULCH LAYER AS INDICATED ON DRAWINGS. MIX APPROXIMATELY HALF OF THE SPECIFIED MULCH LAYER INTO THE BIORETENTION SOIL TO A DEPTH OF APPROXIMATELY 4 INCHES TO HELP FOSTER A HIGHLY ORGANIC SURFACE LAYER.
 - REMOVE REMAINING EROSION AND SEDIMENT CONTROLS ONLY AFTER SURROUNDING DISTURBED AREAS HAVE BEEN PROPERLY STABILIZED.
 - CONDUCT FINAL CONSTRUCTION INSPECTION WITH ENGINEER.
 - CLEAN UP**
 - AFTER COMPLETION OF THE WORK, REMOVE AND PROPERLY DISPOSE ALL DEBRIS, CONSTRUCTION MATERIALS, RUBBISH, EXCESS SOIL, ETC., FROM THE PROJECT SITE. REPAIR PROMPTLY ANY IDENTIFIED DEFICIENCIES AND LEAVE THE PROJECT SITE IN A CLEAN AND SATISFACTORY CONDITION.

MATERIAL SPECIFICATIONS

- BIORETENTION SOIL**
SUBMIT SOIL SAMPLE (2LBS) AND TESTING ANALYSIS RESULTS BY A QUALIFIED SOIL TESTING LABORATORY INDICATING AND INTERPRETING TEST RESULTS FOR COMPLIANCE WITH THE FOLLOWING PARAMETERS:
 - UNIFORM SOIL MIX, FREE OF NOXIOUS WEEDS AND STONES, STUMPS, ROOTS OR OTHER SIMILAR OBJECTS LARGER THAN 1 INCH.
 - PROVIDE USDA UNIFIED SOIL CLASSIFICATION: LOAMY SAND
 - PROVIDE A TEXTURAL ANALYSIS INCLUDING THE GRADATION AND PERCENTAGES OF SAND, SILT, AND CLAY CONTENT

85-88% SAND (< 10% COARSE SAND)	5.2-7.0
8-12% SILT AND CLAY (< 2% CLAY)	
 - ORGANIC MATTER: 3%
WELL AGED (6-12 MONTHS), WELL AERATED, LEAF COMPOST OR APPROVED EQUIVALENT
 - PROVIDE A SOIL TEST OF THE BIORETENTION SOIL FOR CONFORMANCE TO THE FOLLOWING CRITERIA:

PH RANGE:	5.2-7.0
MAGNESIUM:	MINIMUM 32 PPM
PHOSPHOROUS (P2O5):	NOT TO EXCEED 69 PPM
POTASSIUM (K2O):	MINIMUM 78 PPM
SOLUBLE SALTS:	NOT TO EXCEED 500 PPM
- IF THE SOIL PH IS NOT WITHIN THE ACCEPTABLE RANGE, AMEND WITH LIME TO RAISE THE PH OR WITH IRON SULFATE TO LOWER THE PH, AS NECESSARY. ALL TESTING SHOULD BE PERFORMED BY THE SAME TESTING FACILITY TO MAINTAIN CONSISTENT RESULTS. SUBMIT THE SOIL SAMPLE RESULTS TO THE ENGINEER REVIEW AND APPROVAL PRIOR TO DELIVERY TO THE PROJECT SITE.
- VOLUME OF FILTER MEDIA BASED ON 110% OF PLAN VOLUME TO ACCOUNT FOR SETTLING OR COMPACTION.
 - DO NOT MIX, DUMP OR STORE ANY OTHER MATERIALS OR SUBSTANCES THAT MAY BE HARMFUL TO PLANT GROWTH OR PROVE A HINDRANCE TO THE PLANTING MAINTENANCE OR OPERATIONS WITHIN THE BIORETENTION AREA.

- MULCH**
 - FINE SHREDDED WELL AGED (6 MONTH MINIMUM) HARDWOOD MULCH. HARDWOOD MULCH IS PREFERRED TO PREVENT FLOATING. IF HARDWOOD MULCH IS NOT AVAILABLE A FINELY DOUBLE SHREDDED, WELL AGED, ORGANIC DARK PINE MULCH MAY BE ACCEPTABLE ON A CASE BY CASE BASIS PER SAMPLE SUBMITTAL AND ENGINEER REVIEW.
 - A MULCH SAMPLE MUST BE SUBMITTED AND APPROVED BY THE ENGINEER PRIOR TO DELIVERY TO THE PROJECT SITE.
- FILTER FABRIC**
 - NON-WOVEN GEOTEXTILE FABRIC WITH FLOW RATE OF > 110 GALLON/MINUTES/SQUARE FOOT.
 - CLASS "C" APPARENT OPENING SIZE (ASTM-D-4751).
 - GRAB TENSILE STRENGTH (ATSM-D-4832) BURST STRENGTH (ASTM-D-4833).
- PEA GRAVEL**
 - 3/8" WASHED STONE
- UNDERDRAIN GRAVEL**
 - 3/4" CRUSHED WASHED STONE, CLEAN AND FREE OF ALL FINES AND MEETING AASHTO M-43.
- PIPE**
 - UNDERDRAIN
4" RIGID SCHEDULE 40 PVC PIPE, WITH 3/8" PERFORATIONS @ 6" O.C. MEETING ASTM 1785 OR AASHTO M-278.
TS AND YS FITTINGS AS REQUIRED FOR THE UNDERDRAIN CONFIGURATION INDICATED ON DRAWING.
 - CONNECTIONS TO STORM DRAIN SYSTEM.
 - UNDERDRAIN CLEANOUTS
NON PERFORATED SCHEDULE 40 PVC PIPE, PVC ELBOW, CAP, AND ALL ASSOCIATED FITTINGS.
 - EROSION CONTROL BLANKET (3:1 SIDE SLOPES ONLY)**
 - WOVEN, 100% BIODEGRADABLE JUTE FIBER 7.70 LBS/1000 SQFT. BIONET S1508N OR APPROVED EQUIVALENT.
 - PLANTS**
 - AS INDICATED ON DRAWINGS.
 - SEED (SIDE SLOPES ONLY)**
 - NEW ENGLAND CONSERVATION WILDLIFE MIX OR APPROVED EQUIVALENT.
 - APPLICATION RATE 25 LBS/ ACRES OR PER SEED MANUFACTURER'S REQUIREMENTS.
 - OUTLET STRUCTURE**
 - SIZE AS INDICATED ON DRAWINGS.
 - FIBERGLASS REINFORCED PLASTIC MANHOLES OF SIZE INDICATED ON DRAWINGS.

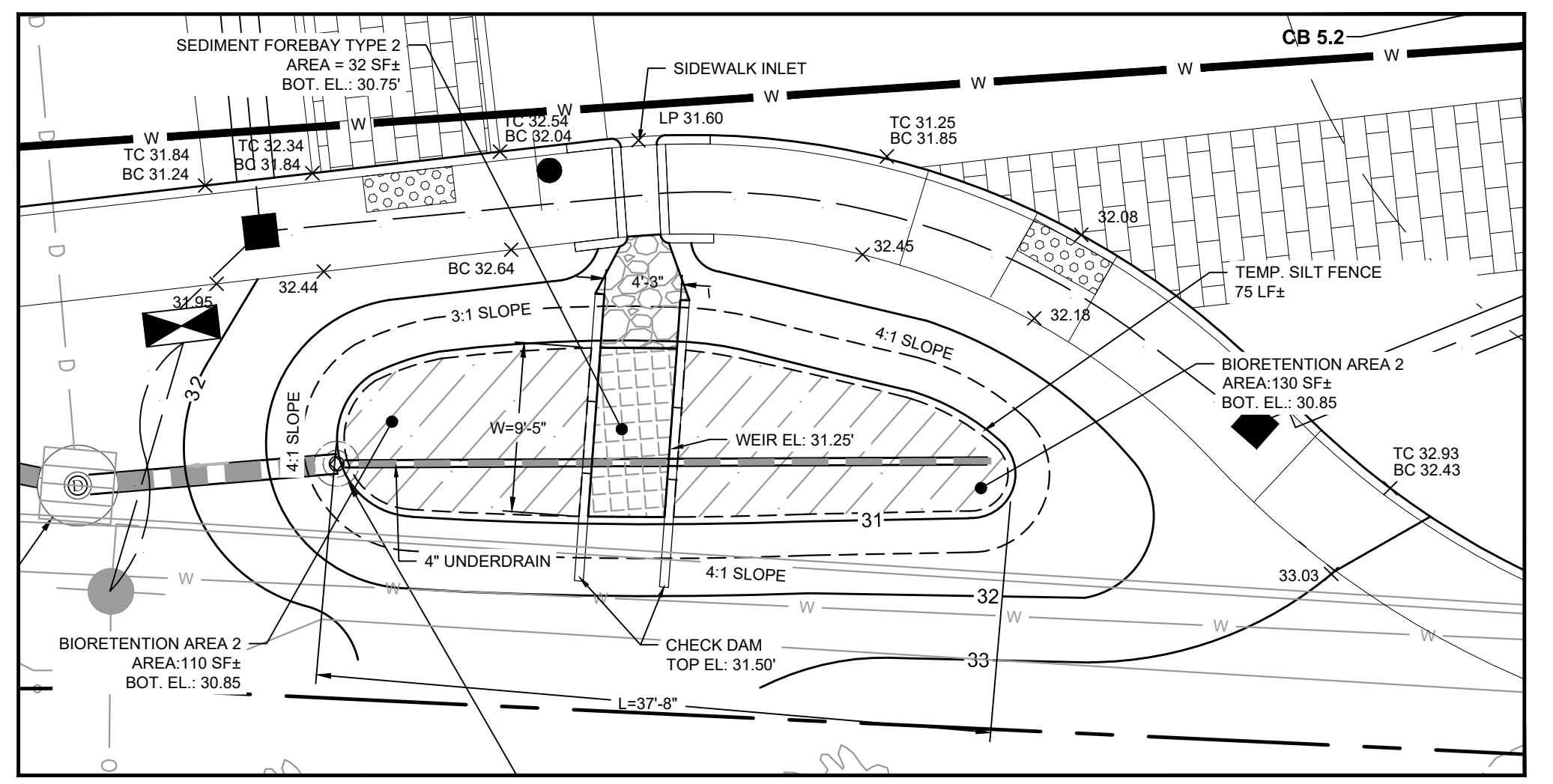

BIORETENTION AREA 2
SCALE: 1/8" = 1'-0"

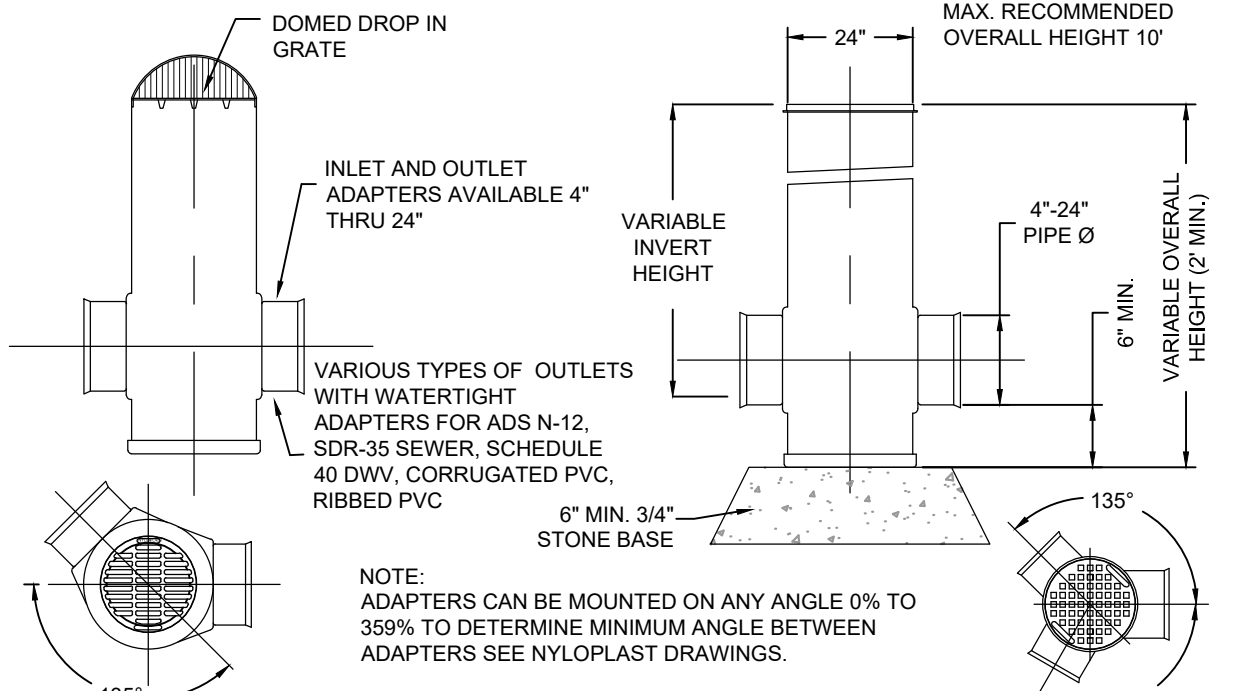

BIO OVERFLOW OUTLET
NOT TO SCALE
BY "NYLOPLAST" OR APPROVED EQUIVALENT

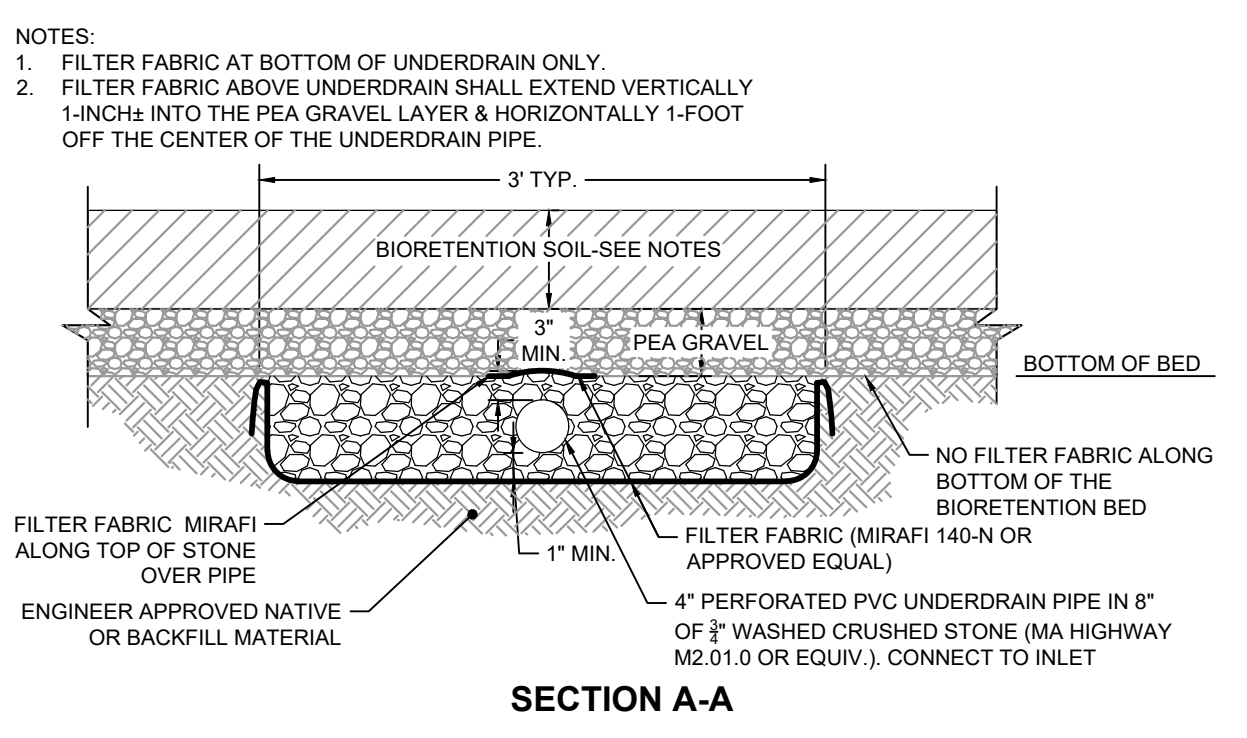

SECTION A-A

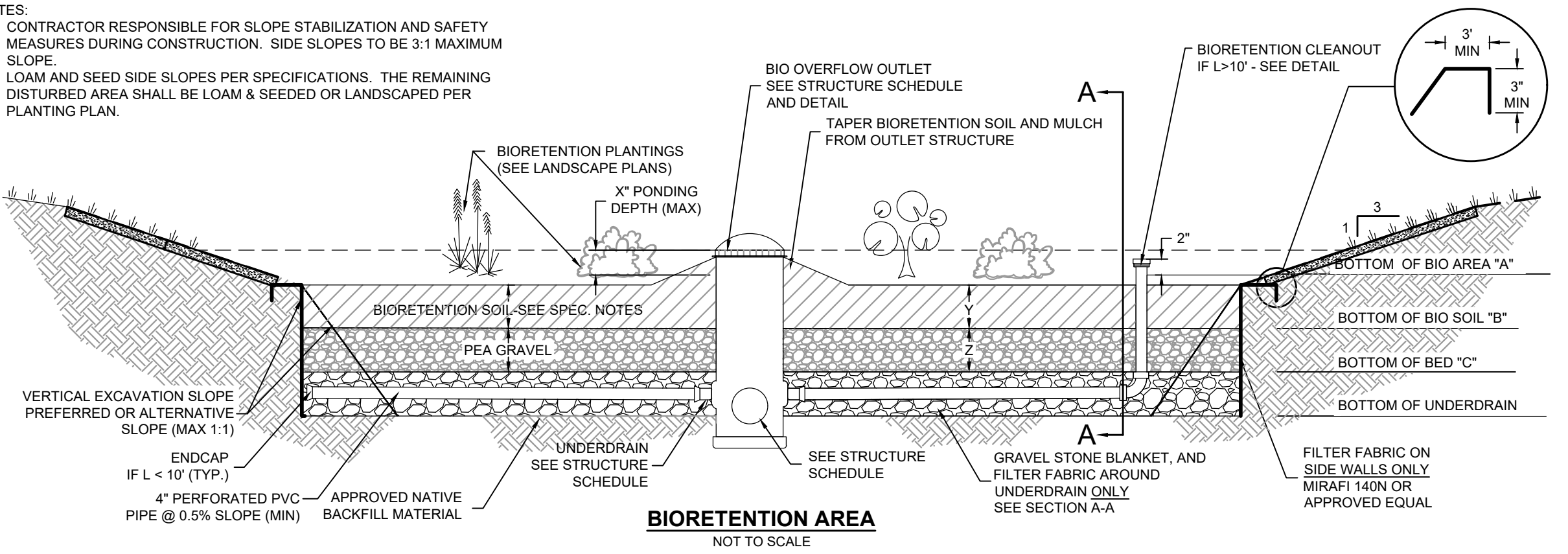

BIORETENTION AREA
NOT TO SCALE

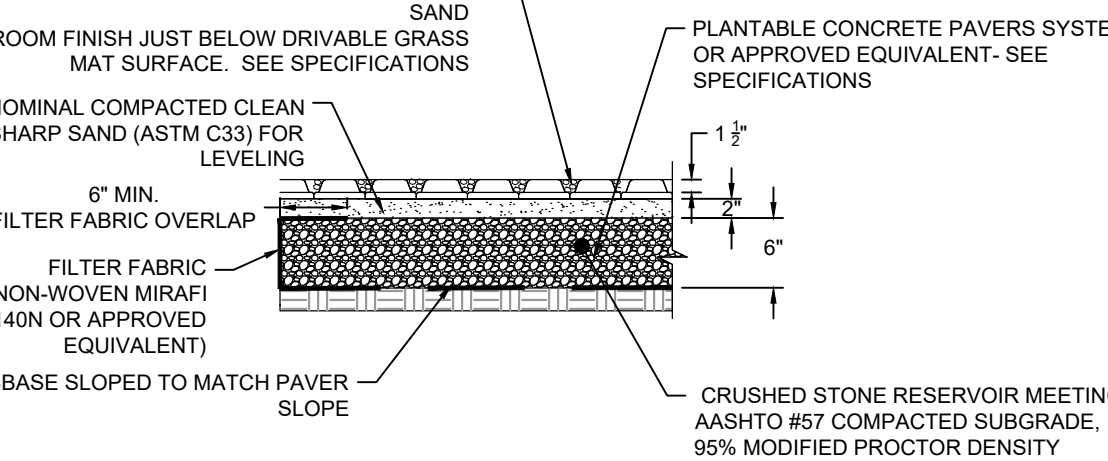
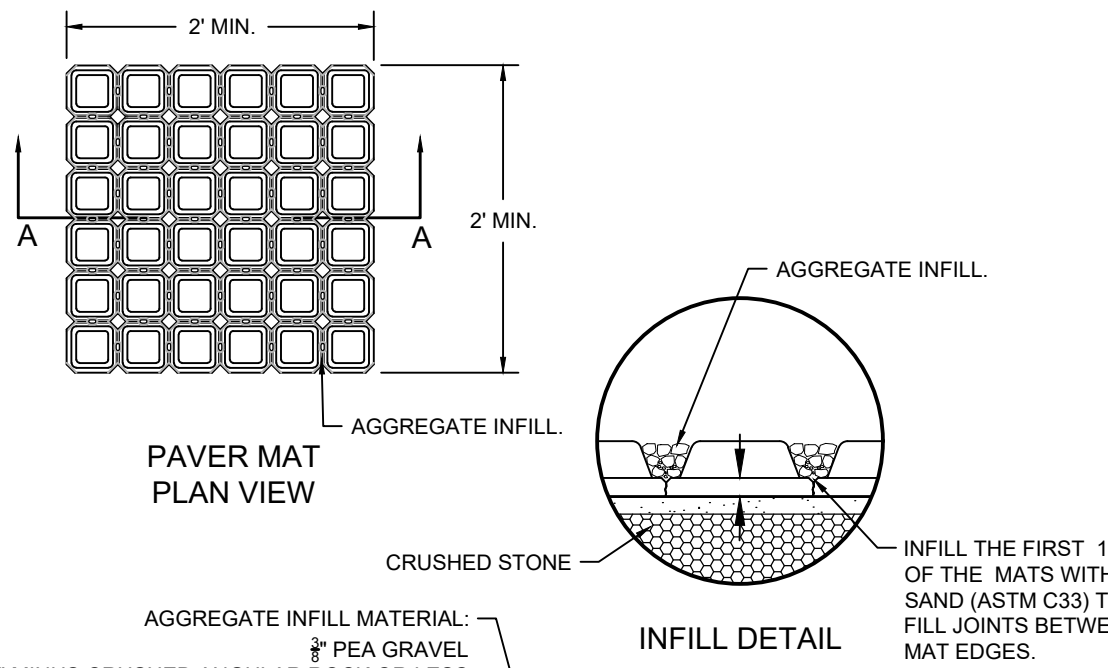

PLANTABLE CONCRETE PAVER
NOT TO SCALE

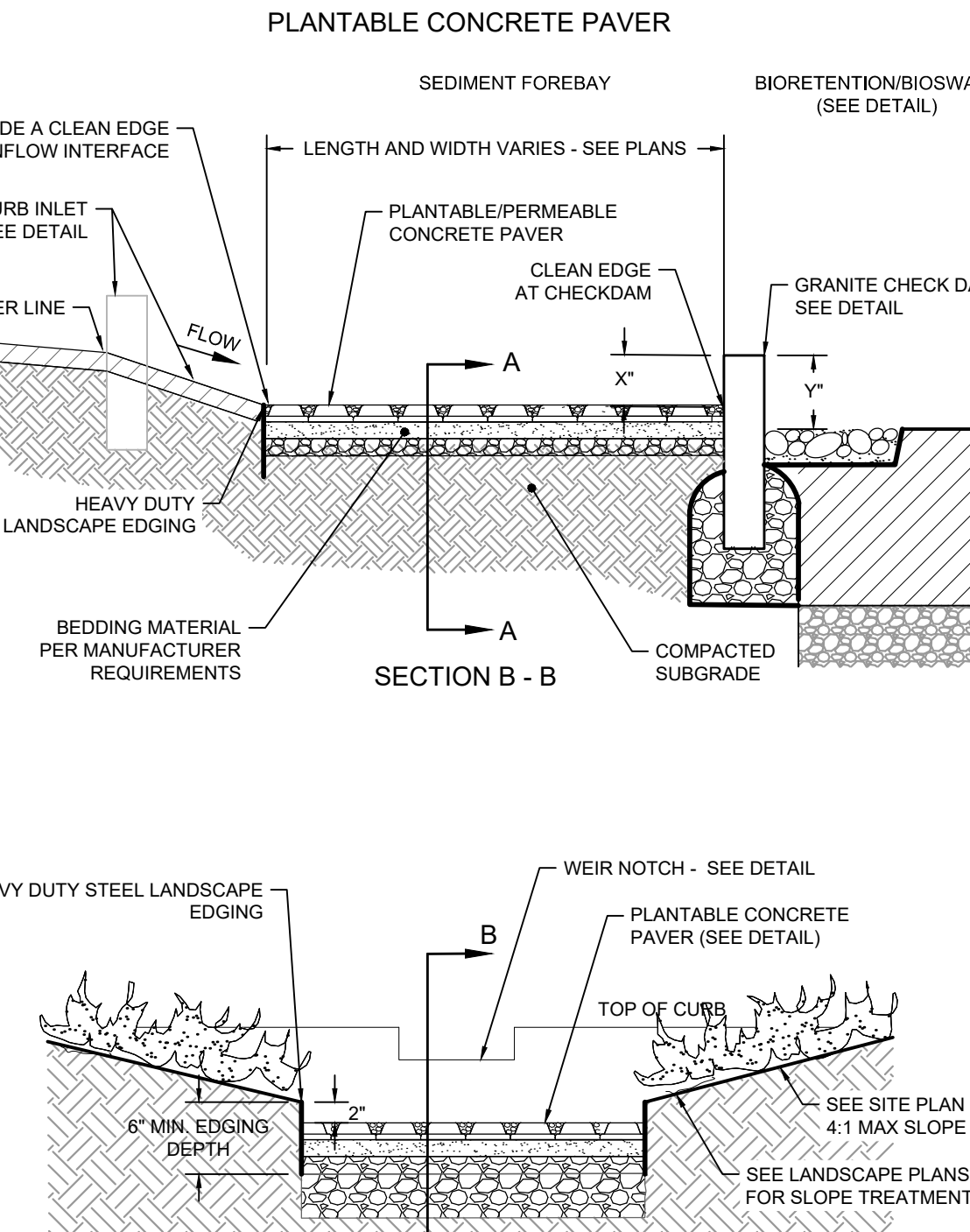

SEDIMENT FOREBAY
NOT TO SCALE

BIORETENTION SCHEDULE:

No.	X		Y		Bottom of Bed (ft)
	Ponding Depth (ft)	Bottom of Bio Area (ft)	Bio Soil Depth (in)	Bottom Bio Soil (ft)	
1	0.33	30.80	18.00	29.30	28.80
2	0.50	30.85	15.00	29.60	29.10

- NOTES:
- CONTRACTOR RESPONSIBLE FOR SLOPE STABILIZATION AND SAFETY MEASURES DURING CONSTRUCTION. SIDE SLOPES TO BE 3:1 MAXIMUM SLOPE.
 - LOAM AND SEED SIDE SLOPES PER SPECIFICATIONS. THE REMAINING DISTURBED AREA SHALL BE LOAM & SEED OR LANDSCAPED PER PLANTING PLAN.

- NOTES:
- SEE SPECIFICATIONS FOR PLANTABLE/PERMEABLE PAVER REQUIREMENTS.
 - INSTALL PLANTABLE/PERMEABLE PAVER SYSTEM PER MANUFACTURERS REQUIREMENTS.
 - SHAPE FOREBAY AS REQUIRED WITH MIN. 6" SIDE SLOPE DEPTH.
 - LANDSCAPE EDGING: HEAVY DUTY STEEL LANDSCAPE EDGING (2" THICKNESS) WITH NATURAL FINISH
 - SEE PLANS FOR DIMENSIONS GRADING AND ELEVATIONS FOR SEDIMENT FOREBAY

SHEET NO.	TOTAL SHEETS
14	108

GENERAL PLANTING NOTES:

- THE FOLLOWING NOTES ARE PROVIDED AS GENERAL PLANTING GUIDELINES ONLY. THOROUGHLY REVIEW THE PROJECT SPECIFICATIONS FOR ALL LANDSCAPE REQUIREMENTS PRIOR TO THE COMMENCEMENT OF ANY LANDSCAPE WORK. SUBMIT IN WRITING TO THE LANDSCAPE ARCHITECT ANY QUESTIONS OR CLARIFICATIONS REQUIRED AT A MINIMUM OF 30 DAYS PRIOR TO ORDERING ANY MATERIALS OR BEGINNING ANY LANDSCAPE CONSTRUCTION.
- SUBMIT TO THE LANDSCAPE ARCHITECT FOR REVIEW AND APPROVAL ALL REQUIRED LANDSCAPE SUBMITTALS AS DESCRIBED IN THE SPECIFICATIONS INCLUDING A PLANT LIST WITH PLANT SIZE AND QUANTITIES TO BE ORDERED PRIOR TO DELIVERY TO THE PROJECT SITE.
- FURNISH AND INSTALL ALL PLANTS AS SHOWN ON THE DRAWINGS AND IN THE SIZE AND QUANTITIES SPECIFIED ON THE PLANTING SCHEDULE. PLANT SUBSTITUTION SELECTION MUST BE APPROVED BY BIOLOGIST OR LANDSCAPE ARCHITECT PRIOR TO INSTALLATION.
- ALL PLANTS TO COMPLY WITH APPLICABLE REQUIREMENTS OF ANSI Z60.1 "AMERICAN STANDARD FOR NURSERY STOCK" LATEST EDITION, PUBLISHED BY THE AMERICAN NURSERY AND LANDSCAPE ASSOCIATION INC.
- PLANTS TO BE GROWN UNDER CLIMATIC CONDITIONS SIMILAR TO THOSE IN THE LOCALITY OF THE PROJECT FOR AT LEAST TWO (2) YEARS. USE HEALTHY NURSERY GROWN PLANTS, FREE OF DISEASE, INSECTS, AND PESTS. EGGS OR LARVAE, AND HAVE A WELL DEVELOPED ROOT SYSTEM.
- INSTALL PLANTS WITHIN ONE (1) WEEK OF PURCHASE. IF PLANTS ARE TO BE STORED AT THE SITE PRIOR TO PLANTING, IT IS THE CONTRACTOR'S RESPONSIBILITY TO ENSURE THEY ARE PROPERLY MAINTAINED, WATERED, AND REMAIN HEALTHY.
- PROCEED WITH PLANTING ONLY WHEN EXISTING AND FORECASTED WEATHER CONDITIONS PERMIT. SUBMIT TO THE LANDSCAPE ARCHITECT IN WRITING THE PROPOSED PLANTING SCHEDULE. OBTAIN APPROVAL OF PLANTING SCHEDULE FROM THE LANDSCAPE ARCHITECT PRIOR TO PERFORMING ANY WORK.
- SEASONS FOR PLANTING:

SPRING:	DECIDUOUS:	APRIL 1 TO JUNE 15
	EVERGREEN:	APRIL 1 TO JUNE 15
	PERENNIALS:	APRIL 15 TO JUNE 1
	GROUNDCOVERS:	APRIL 15 TO JUNE 1
FALL:	DECIDUOUS:	SEPTEMBER 15 TO NOVEMBER 15
	EVERGREEN:	SEPTEMBER 15 TO NOVEMBER 15
	PERENNIALS:	SEPTEMBER 15 TO NOVEMBER 15
	GROUNDCOVERS:	SEPTEMBER 15 TO NOVEMBER 15

LIVE STAKES: PLANTS WHILE DORMANT FROM DECEMBER 1ST THROUGH MARCH 31ST
- PLANTING UNDER FROZEN CONDITIONS IN EITHER THE SPRING OR FALL WILL NOT BE PERMITTED. PLANTING BEFORE OR AFTER THE ABOVE REFERENCED PLANTING DATES WILL INCREASE THE LIKELIHOOD OF PLANT OR GRASS SEED ESTABLISHMENT FAILURE. ANY DEVIATION FROM THE ABOVE REFERENCED PLANTING DATES IS UNDERTAKEN AT SOLE RISK OF THE CONTRACTOR AND IT IS THE RESPONSIBILITY OF THE CONTRACTOR TO PROVIDE ANY ADDITIONAL MAINTENANCE AND WATERING WHICH MAY BE REQUIRED TO ENSURE SATISFACTORY PLANT AND SEED ESTABLISHMENT.
- FURNISH ONE YEAR MANUFACTURER WARRANTY FOR TREES, PLANTS, AND GROUND COVER AGAINST DEFECTS INCLUDING DEATH AND UNSATISFACTORY GROWTH, EXCEPT FOR DEFECTS RESULTING FROM LACK OF ADEQUATE MAINTENANCE, NEGLIGENCE, OR ABUSE BY OWNER, OR ABNORMAL WEATHER CONDITIONS UNUSUAL FOR WARRANTY PERIOD. THE DATE OF FINAL ACCEPTANCE OF ALL COMPLETED PLANTING WORK ESTABLISHES THE END OF INSTALLATION AND INITIAL MAINTENANCE PERIOD AND THE COMMENCEMENT OF THE GUARANTEE PERIOD.
- ALL TREES WITHIN 5'-0" OF WALKWAYS AND SIDEWALKS TO HAVE A 6'-8" STANDARD BRANCHING HEIGHT.
- INSPECT ALL AREAS TO BE PLANTED OR SEEDED PRIOR TO STARTING ANY LANDSCAPE WORK. REPORT ANY DEFECTS SUCH AS INCORRECT GRADING, INCORRECT SUBGRADE ELEVATIONS OR DRAINAGE PROBLEMS, ETC. TO THE LANDSCAPE ARCHITECT AND ENGINEER PRIOR TO BEGINNING WORK. COMMENCEMENT OF WORK INDICATES ACCEPTANCE OF SUBGRADE AREAS TO BE PLANTED, AND THE LANDSCAPE CONTRACTOR ASSUMES RESPONSIBILITY FOR ALL LANDSCAPE WORK.
- PROVIDE PROPER PREPARATION OF ALL PROPOSED PLANTED AND SEEDED AREAS PER THE NOTES AND SPECIFICATIONS.
- ALL PLANT LAYOUT AND ACTUAL PLANTING LOCATIONS ARE TO BE FIELD VERIFIED BY LANDSCAPE ARCHITECT PRIOR TO PLANTING. NOTIFY THE LANDSCAPE ARCHITECT AT A MINIMUM OF 48 HOURS IN ADVANCE PRIOR TO SCHEDULING ANY FIELD INSPECTIONS.
- BALL AND BURLAP: REMOVE BURLAP AND WIRE BASKETS FROM TOPS OF BALLS AND FROM TOP HALF OF ROOTBALL AS INDICATED ON DRAWINGS. REMOVE PALLETS, IF ANY, BEFORE SETTING.
- POTTED PLANTS: REMOVE THE PLANT FROM THE POT AND LOOSEN OR SCORE THE ROOTS BEFORE PLANTING TO PROMOTE OUTWARDS ROOT GROWTH INTO THE SOIL.
- PLUGS: PLANT UPRIGHT AND NOT AT AN ANGLE. DIG PLANTING HOLES LARGE ENOUGH AND DEEP ENOUGH TO ACCOMMODATE THE ENTIRE ROOT MASS. PLANT PLUGS WITH NO TWISTED OR BALLED ROOTS AND WITH NO ROOTS EXPOSED ABOVE THE GRADE LINE. HAND PACK THE SOIL AROUND THE ENTIRE PLUG ROOT MASS.
- DIG THE PLANTING HOLE TO THE SAME DEPTH AS THE ROOT BALL AND TWO TO THREE TIMES WIDER. SCORE ALL SIDES OF THE HOLE, PLACE THE PLANT IN THE HOLE SO THE TOP OF ROOT BALL IS EVEN WITH SOIL SURFACE. FILL THE HOLE HALFWAY AND THEN ADD WATER ALLOWING IT TO SEEP INTO BACK FILLED MATERIAL. BE SURE TO REMOVE ALL AIR POCKETS FROM BACK FILLED SOIL. DO NOT SPREAD SOIL ON TOP OF THE ROOTBALL. IF SOIL IS EXTREMELY POOR, REPLACE BACK FILL WITH GOOD QUALITY TOP SOIL. AMEND THE SOIL, AS NECESSARY.
- CREATE A 2" TO 4" BERM AROUND THE EDGE OF PLANTING HOLE WITH REMAINING SOIL TO RETAIN WATER.
- REMOVE ALL PLANT TAGS AND FLAGS FROM THE PLANTS.
- MULCH ALL PLANTING BEDS AS INDICATED ON DRAWINGS. UNLESS NOTED OTHERWISE, ALL PLANTS TO RECEIVE 2-3 INCHES OF MULCH. DO NOT ADD MULCH TO BIORETENTION AND STORMWATER MANAGEMENT AREAS DO NOT PILE OR MOUND MULCH AROUND THE PLANT STEMS OR TRUNK.
- TRIM BROKEN AND DEAD BRANCHES FROM TREES AND SHRUBS AFTER PLANTING. NEVER CUT A LEADER.

GENERAL SEEDING NOTES:

- SEND A REPRESENTATIVE SAMPLE OF THE TOPSOIL TO A TESTING LABORATORY FOR STANDARD SOIL ANALYSIS AS DESCRIBED IN THE SPECIFICATIONS. SUBMIT TO THE LANDSCAPE ARCHITECT AND ENGINEER TEST RESULTS WITH RECOMMENDED SOIL TREATMENTS TO PROMOTE PLANT AND GRASS GROWTH. CORRECT DEFICIENCIES IN THE LOAM AND STOCKPILED TOPSOIL AS DIRECTED BY THE TESTING AGENCY.
- ALL AREAS THAT ARE DISTURBED AND/OR GRADED DURING CONSTRUCTION ARE TO BE BROUGHT TO FINISHED GRADE WITH AT LEAST 4" MINIMUM DEPTH OF GOOD QUALITY LOAM AND SEEDED WITH A QUICK GERMINATING GRASS SEED SUCH AS NEW ENGLAND EROSION CONTROL RESTORATION MIX OR AS SPECIFIED ON THE PLANS.
- PRIOR TO THE PLACEMENT OF TOP SOIL, LOOSEN THE SUBGRADE OF ALL PROPOSED SEEDED AREAS TO A DEPTH OF 6" AND RAKE TO REMOVE STONES LARGER THAN 1 INCH, STICKS, ROOTS, RUBBISH AND OTHER EXTRANEOUS MATTER AND LEGALLY DISPOSE TO AN OFF SITE LOCATION.
- DO NOT SPREAD TOPSOIL IF THE SUBGRADE IS FROZEN, EXCESSIVELY WET, COMPACTED OR NOT PROPERLY PREPARED PER THE NOTES AND SPECIFICATIONS.

WATERING NOTES:

- PROVIDE PROPER PLANT CARE, MAINTENANCE AND WATERING ON SITE UNTIL SUCH TIME AS THE LANDSCAPING IS ACCEPTED BY THE PROPERTY OWNER AS SATISFACTORY PER THE SPECIFICATIONS OR AS DETERMINED BY ANY WRITTEN AGREEMENTS BETWEEN THE CONTRACTOR AND PROPERTY OWNER.
- ESTABLISH AN APPROPRIATE WATERING SCHEDULE FOR ALL PLANT MATERIAL BASED UPON PLANT SPECIES REQUIREMENTS AND PROVIDE IN WRITING TO THE LANDSCAPE ARCHITECT AND OWNER FOR REVIEW AND APPROVAL. ADHERE TO THE APPROVED SCHEDULE UNTIL PLANTS ARE FULLY ESTABLISHED.
- AT A MINIMUM, THE NEWLY SEEDED AND/OR HYDROSEEDED LAWNS SHOULD BE WATERED 2-3 TIMES A DAY. SPECIAL CARE SHOULD BE TAKEN TO ENSURE THAT THE LAWN IS NOT SATURATED DURING WATERING. IF AN IRRIGATION SYSTEM IS NOT PROVIDED, A TEMPORARY IRRIGATION SYSTEM OR HANDHELD GARDEN HOSE SHALL BE USED FOR WATERING SEEDED AREAS. THE AREA MUST BE MAINTAINED CONSISTENTLY MOIST FOR THE BEST GERMINATION RESULTS. ADDITIONAL WATERING WILL BE REQUIRED IF PLANTING AND SEEDING OCCUR OUTSIDE OF THE RECOMMENDED PLANTING SEASONS.

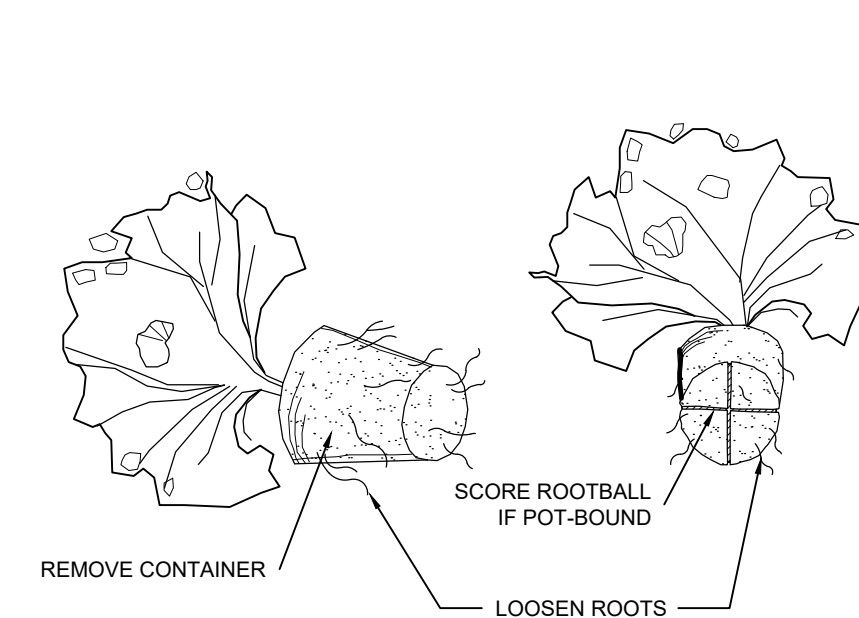

CONTAINER PLANT ROOTBALL TREATMENT
NOT TO SCALE

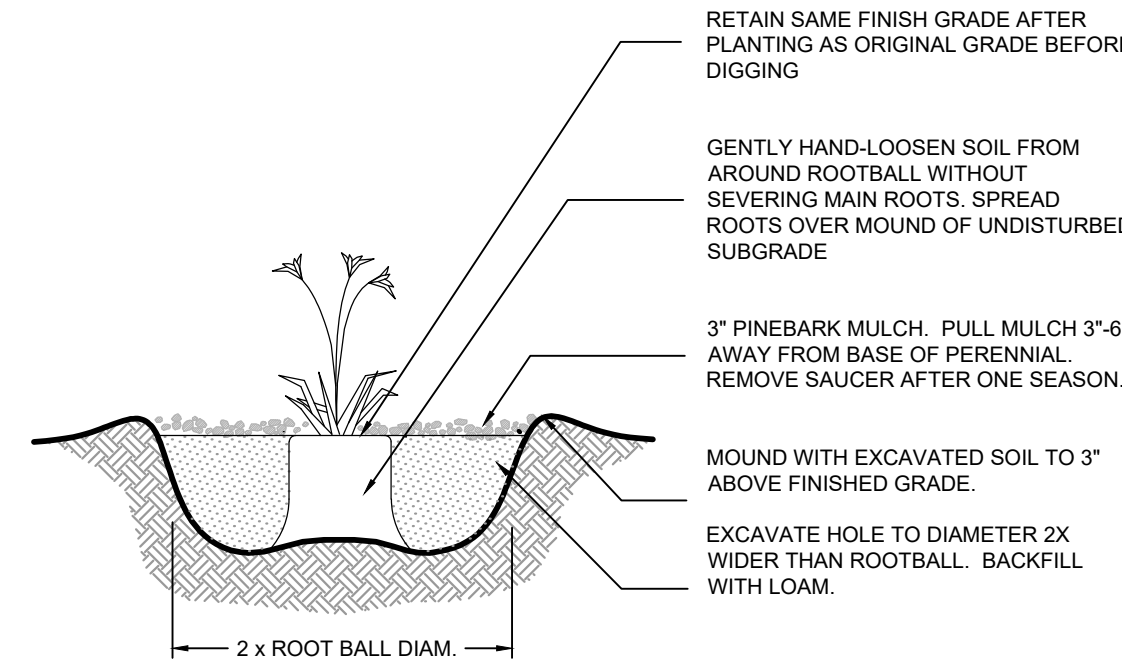

PERENNIAL PLANTING
NOT TO SCALE

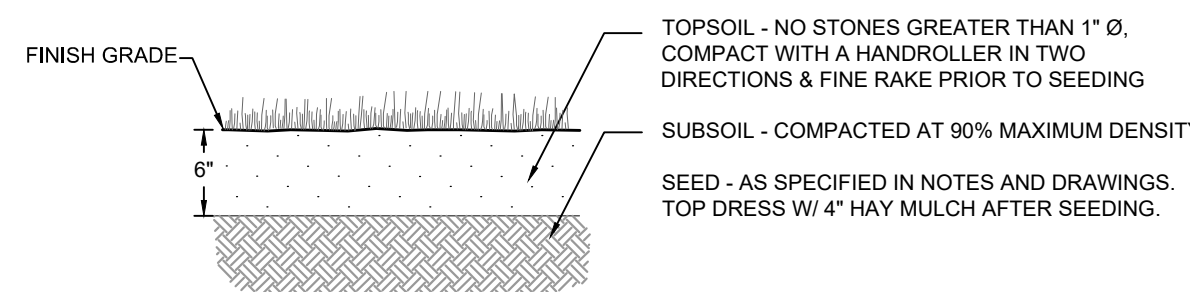

LOAM AND SEED
NOT TO SCALE

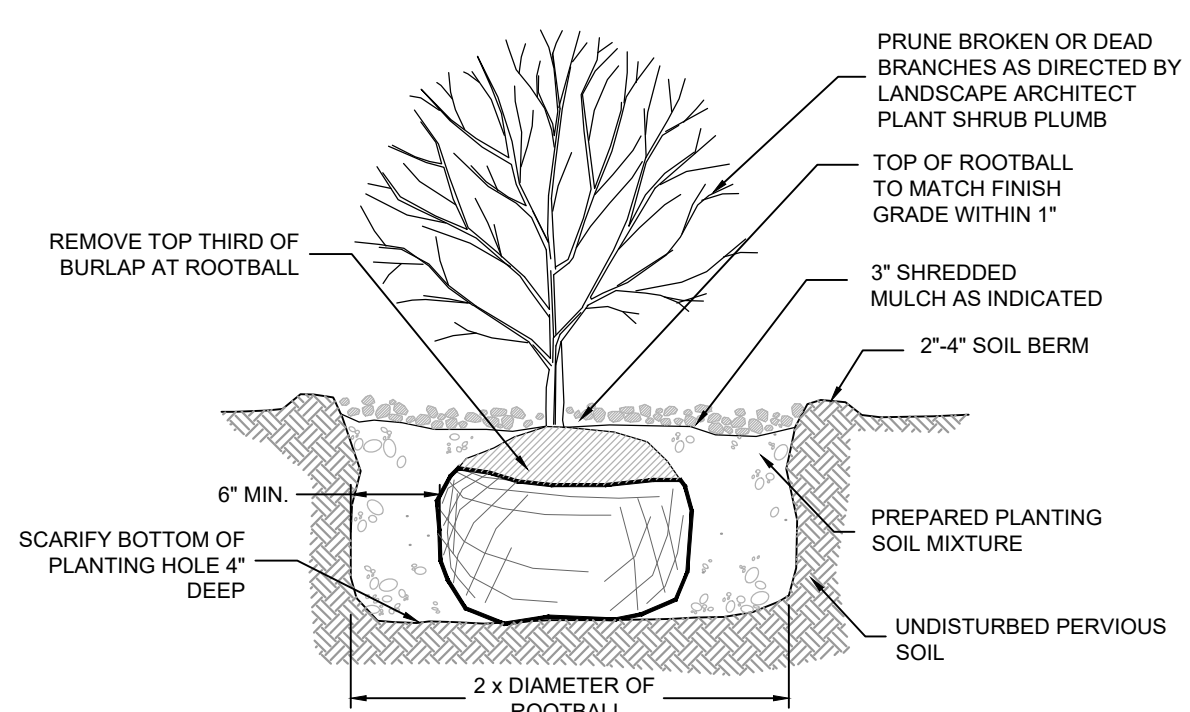

SHRUB PLANTING
NOT TO SCALE

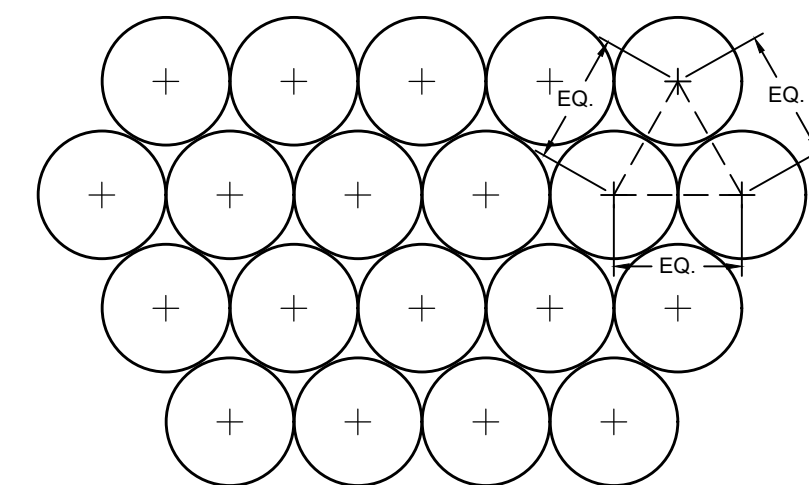

PLANTING SPACING
NOT TO SCALE

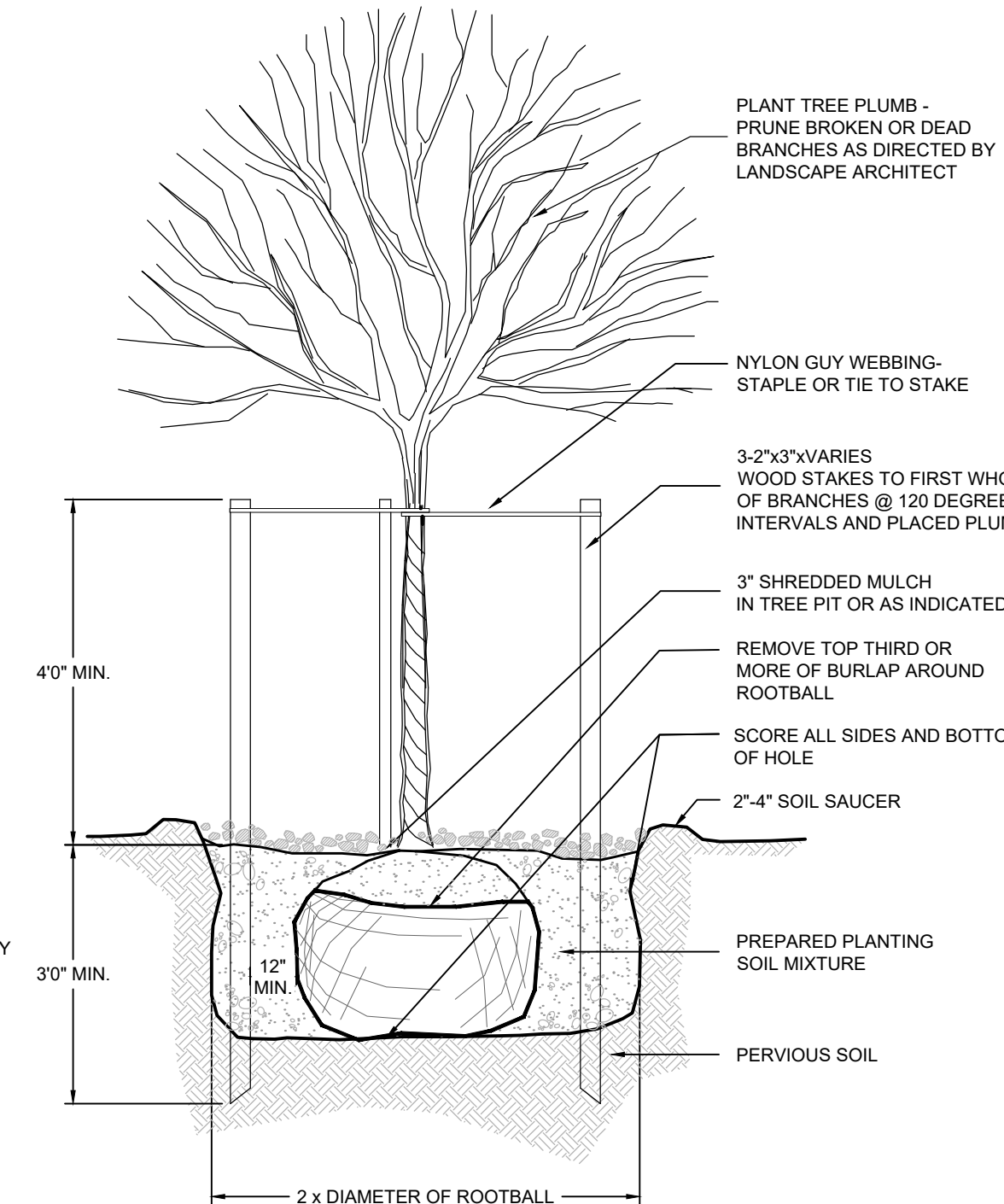

TREE PLANTING
NOT TO SCALE

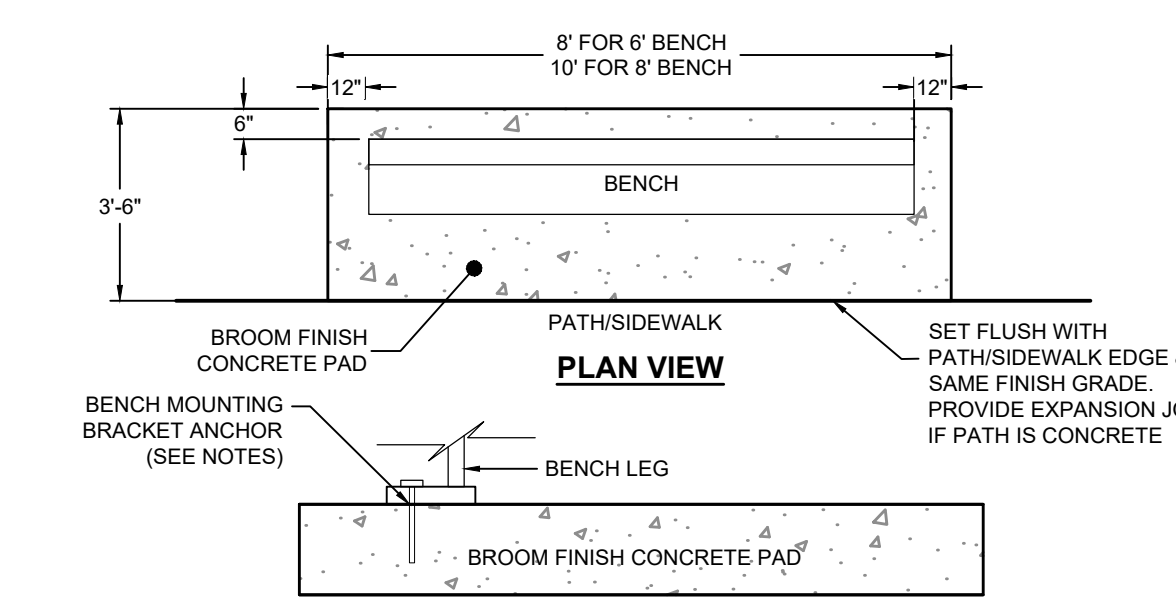

BENCH CONCRETE PAD
NOT TO SCALE

- NOTES:
- ANCHOR BENCH TO CONCRETE PAD PER SPECIFICATIONS AND BENCH MANUFACTURER REQUIREMENTS.
 - BENCH MANUFACTURER: SEE SPECIFICATIONS
 - BENCH STYLE: SEE SPECIFICATIONS

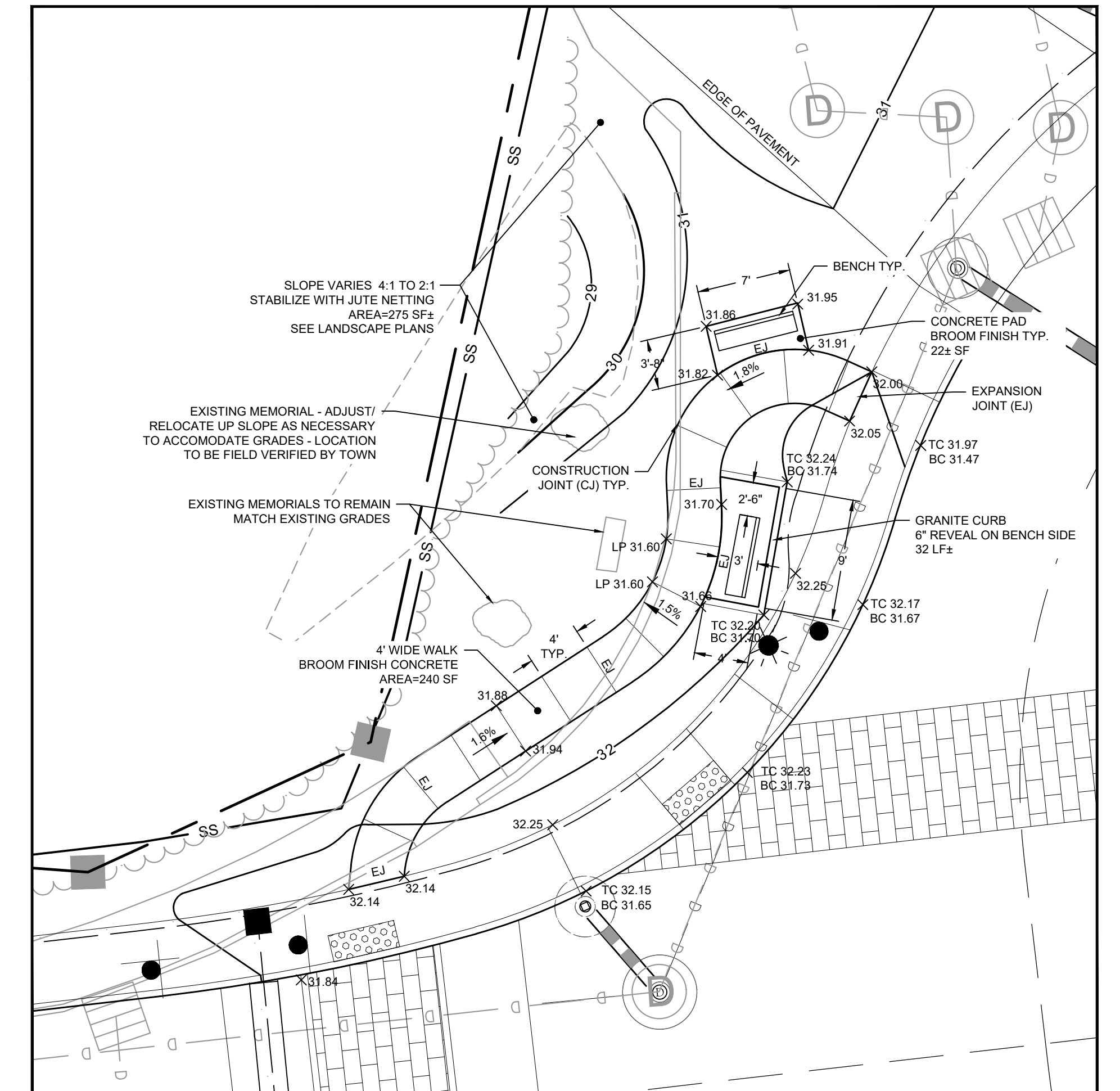

GATEWAY NODE 2 DETAIL PLAN
SCALE: 1/8" = 1'-0"

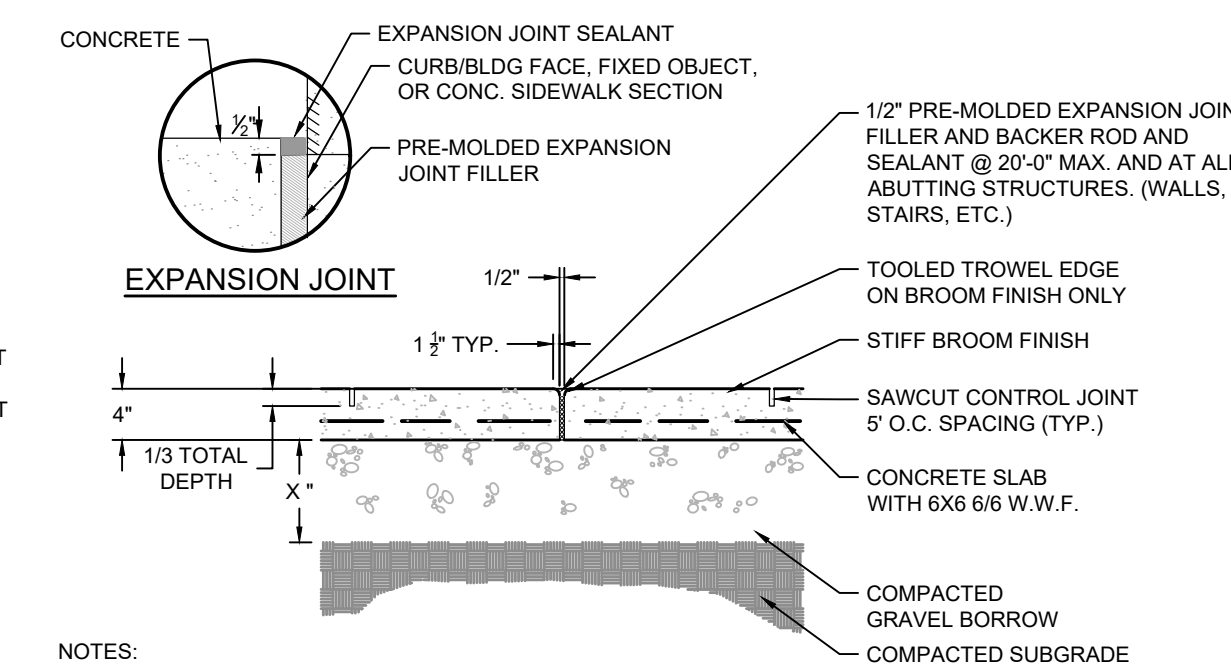

BROOM FINISH CONCRETE
NOT TO SCALE

- NOTES:
- FINISH: BROOM FINISH
 - CEMENT CONCRETE: 4,000 PSI-TYPE II
 - SUBBASE: COMPACTED TO 95%.

BARNSTABLE
MARSTONS MILLS VILLAGE CENTER IMPROVEMENTS

SHEET NO.	TOTAL SHEETS
15	109

CONSTRUCTION PLAN
SHEET 1 OF 8

REV #	DATE
1	11/28/18

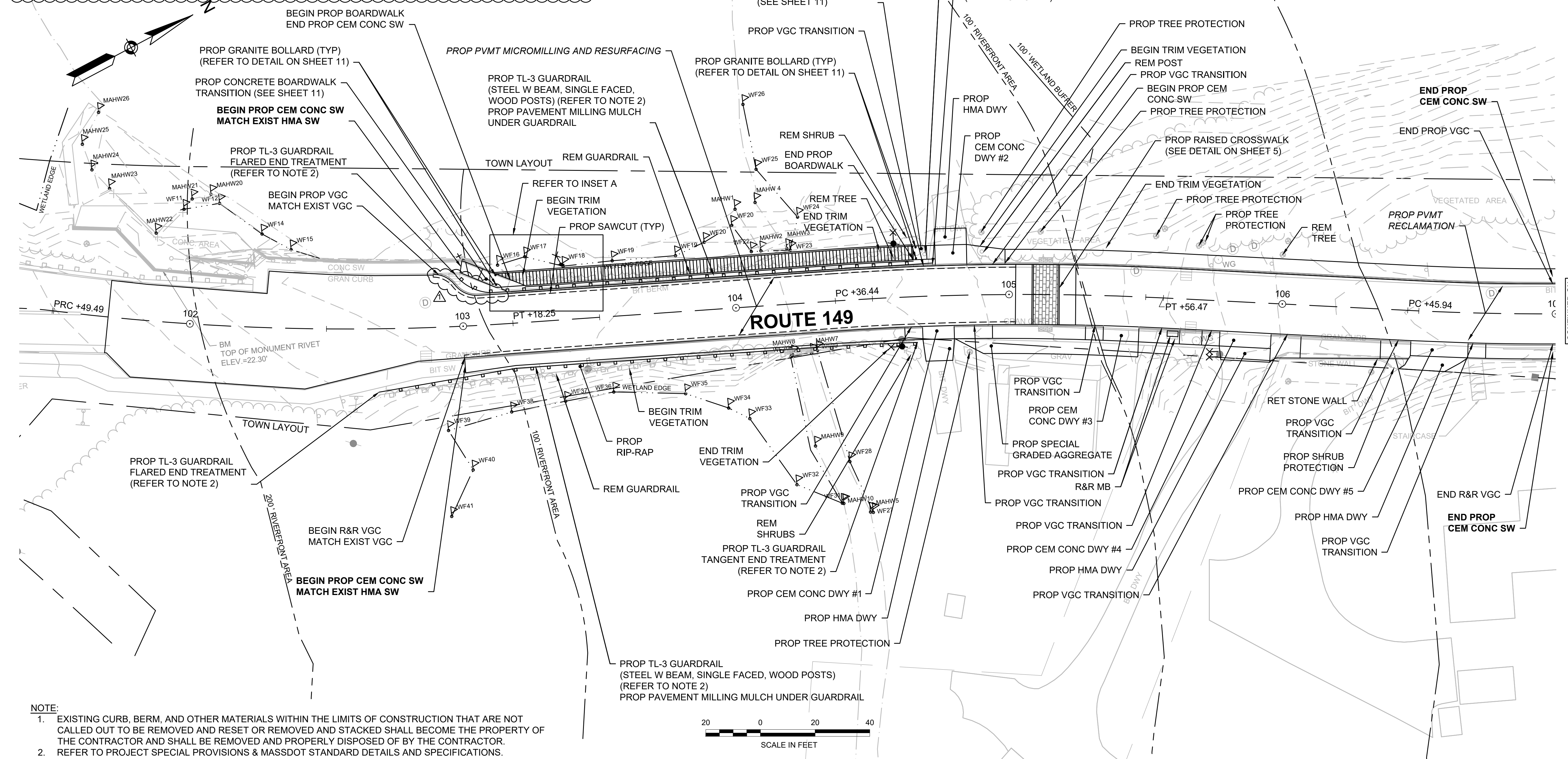
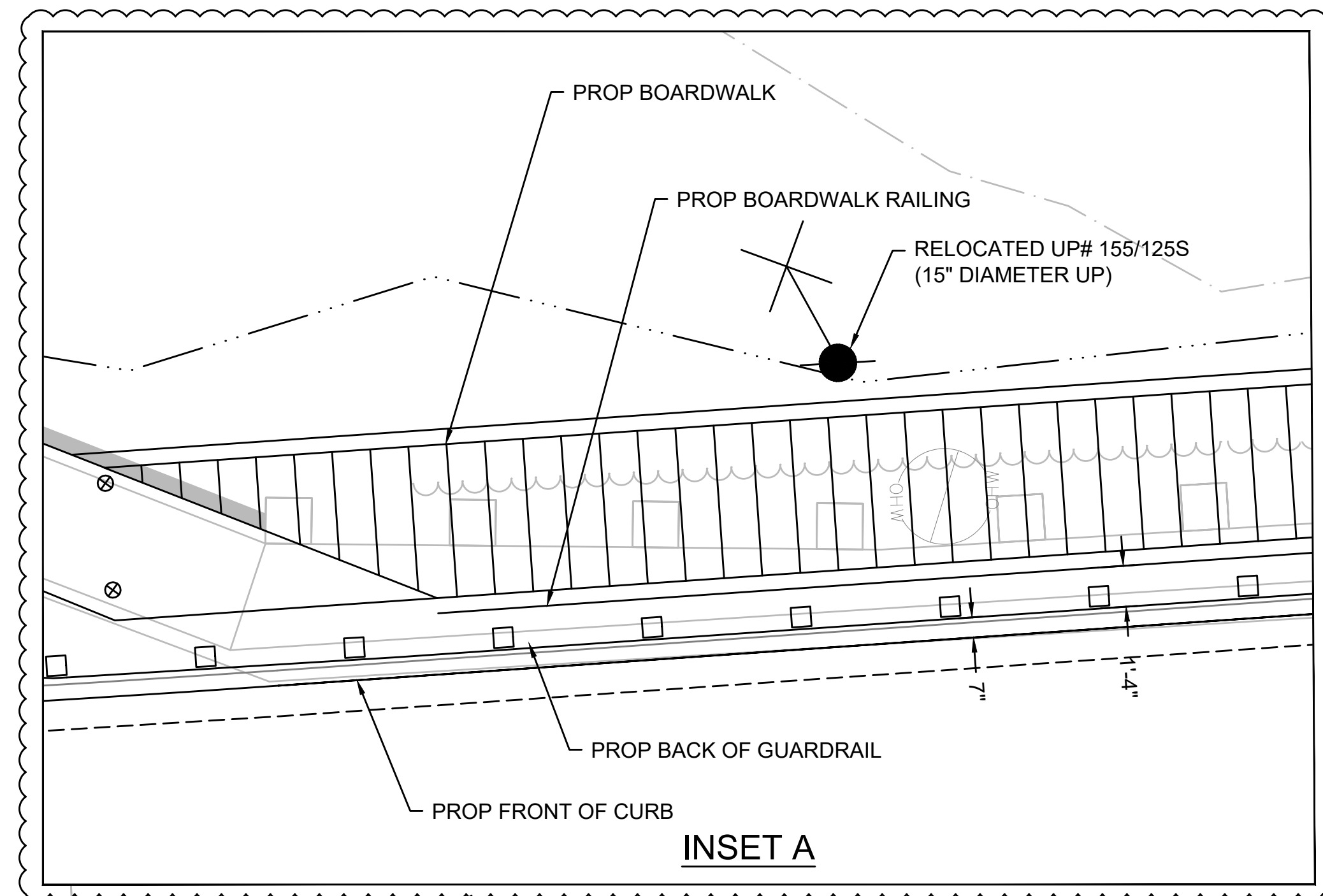

NOTE:
 1. EXISTING CURB, BERM, AND OTHER MATERIALS WITHIN THE LIMITS OF CONSTRUCTION THAT ARE NOT CALLED OUT TO BE REMOVED AND RESET OR REMOVED AND STACKED SHALL BECOME THE PROPERTY OF THE CONTRACTOR AND SHALL BE REMOVED AND PROPERLY DISPOSED OF BY THE CONTRACTOR.
 2. REFER TO PROJECT SPECIAL PROVISIONS & MASSDOT STANDARD DETAILS AND SPECIFICATIONS.

CONTINUED ON
SHEET NO. 16

**BARNSTABLE
MARSTONS MILLS VILLAGE CENTER IMPROVEMENTS**

SHEET NO.	TOTAL SHEETS
16	109

**CONSTRUCTION PLAN
SHEET 2 OF 8**

REV #	DATE
1	11/28/18

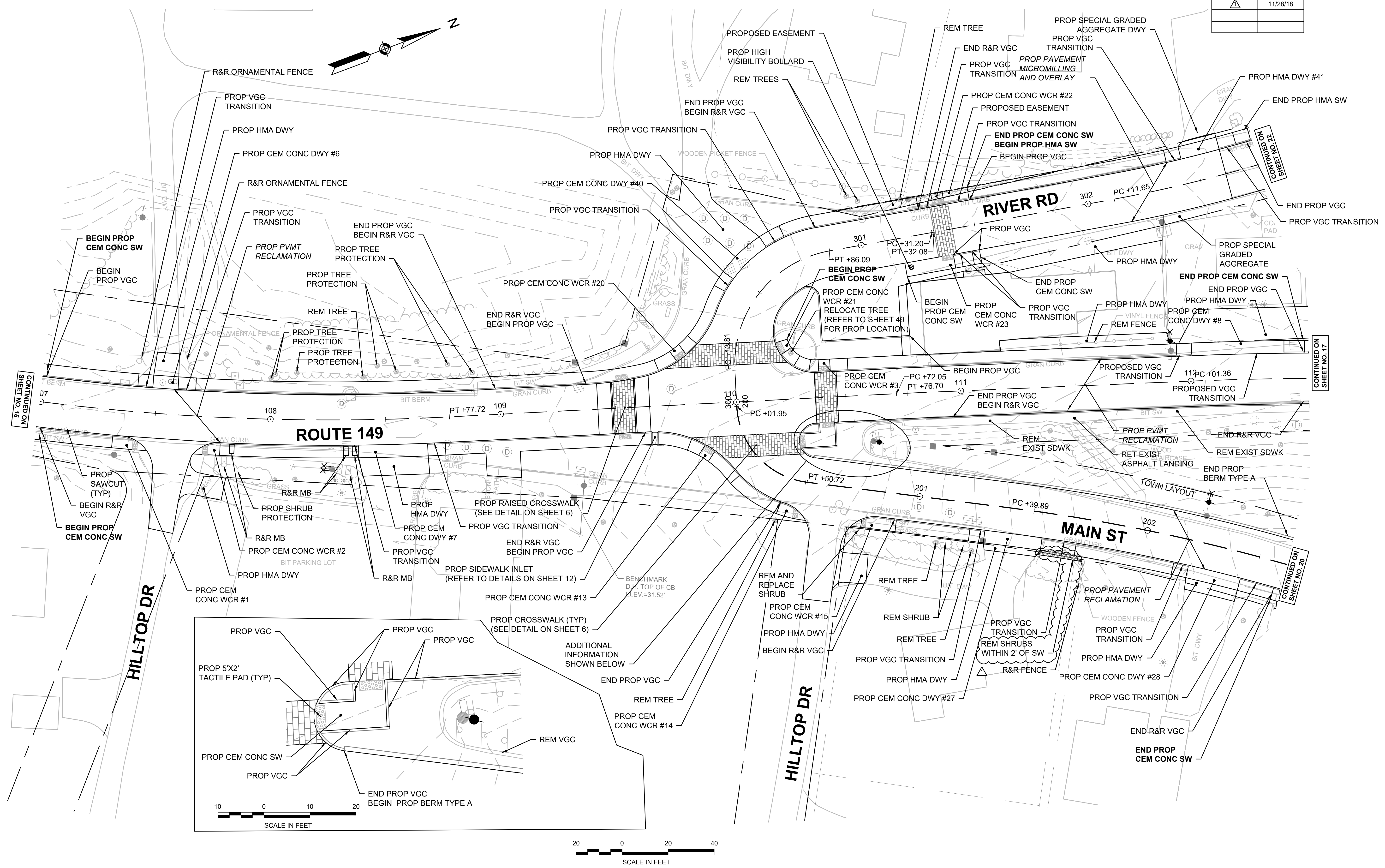

BARNSTABLE
MARSTONS MILLS VILLAGE CENTER IMPROVEMENTS

SHEET NO.	TOTAL SHEETS
17	109

CONSTRUCTION PLAN
SHEET 3 OF 8

12674 - CONSTRUCTION.DWG 18-Oct-2018

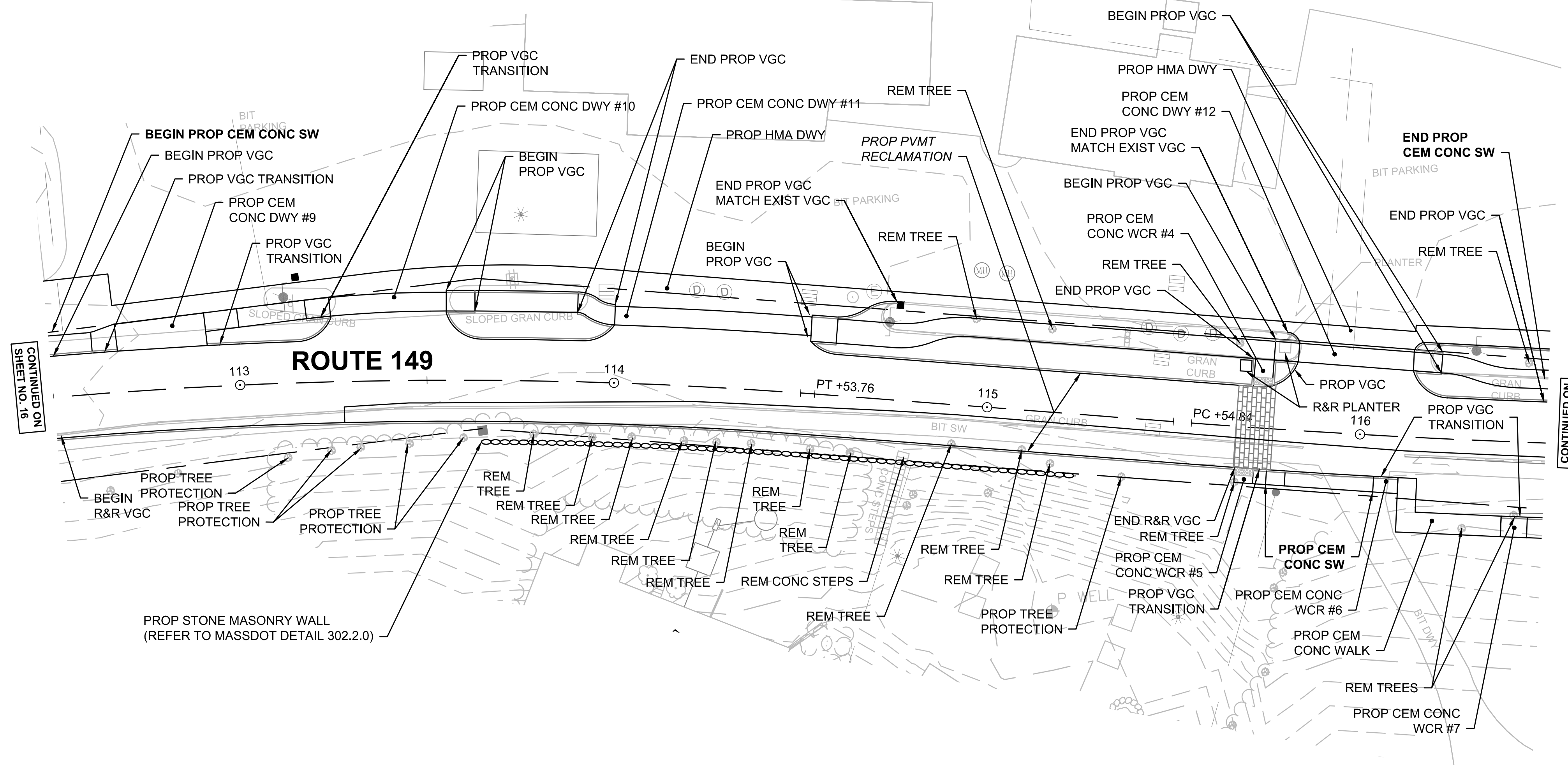
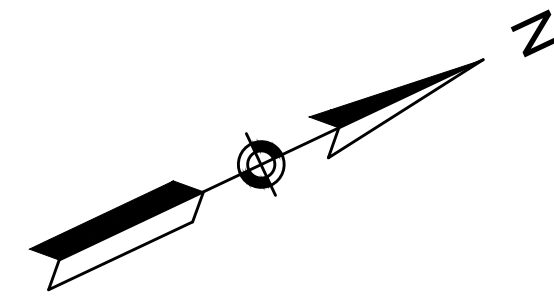

CONTINUED ON SHEET NO. 18

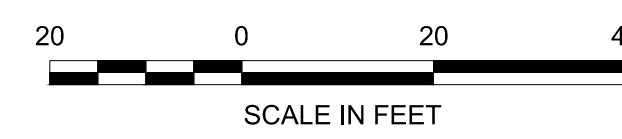

BARNSTABLE
MARSTONS MILLS VILLAGE CENTER IMPROVEMENTS

SHEET NO.	TOTAL SHEETS
18	109

CONSTRUCTION PLAN
SHEET 4 OF 8

REV #	DATE
1	3/18/19

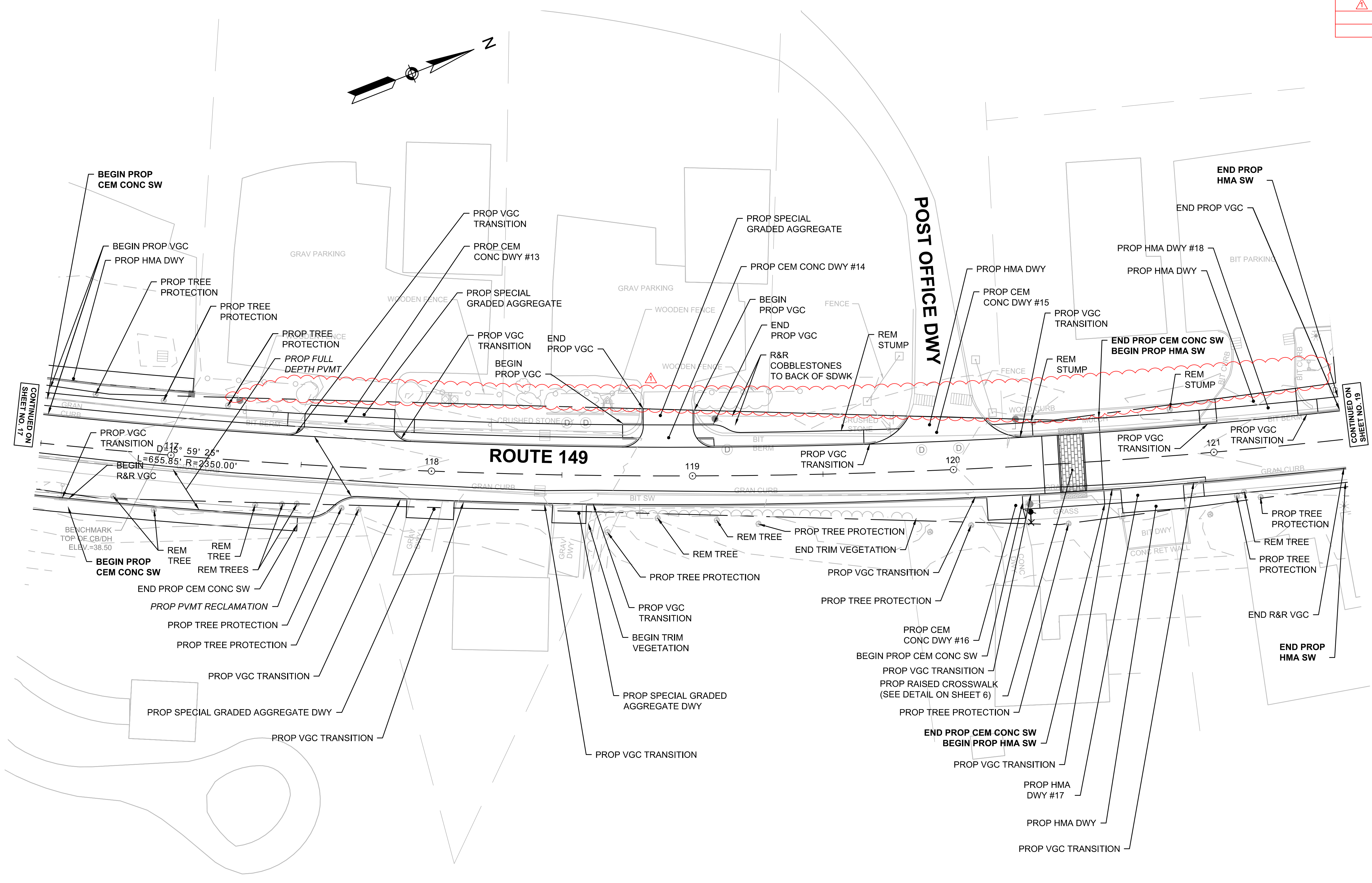

CONTINUED ON
SHEET NO. 17

CONTINUED ON
SHEET NO. 19

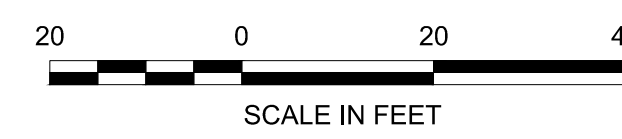

SHEET NO.	TOTAL SHEETS
19	109

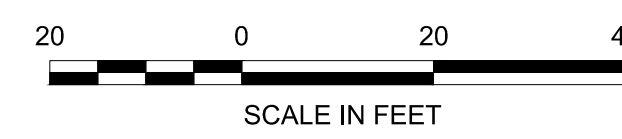
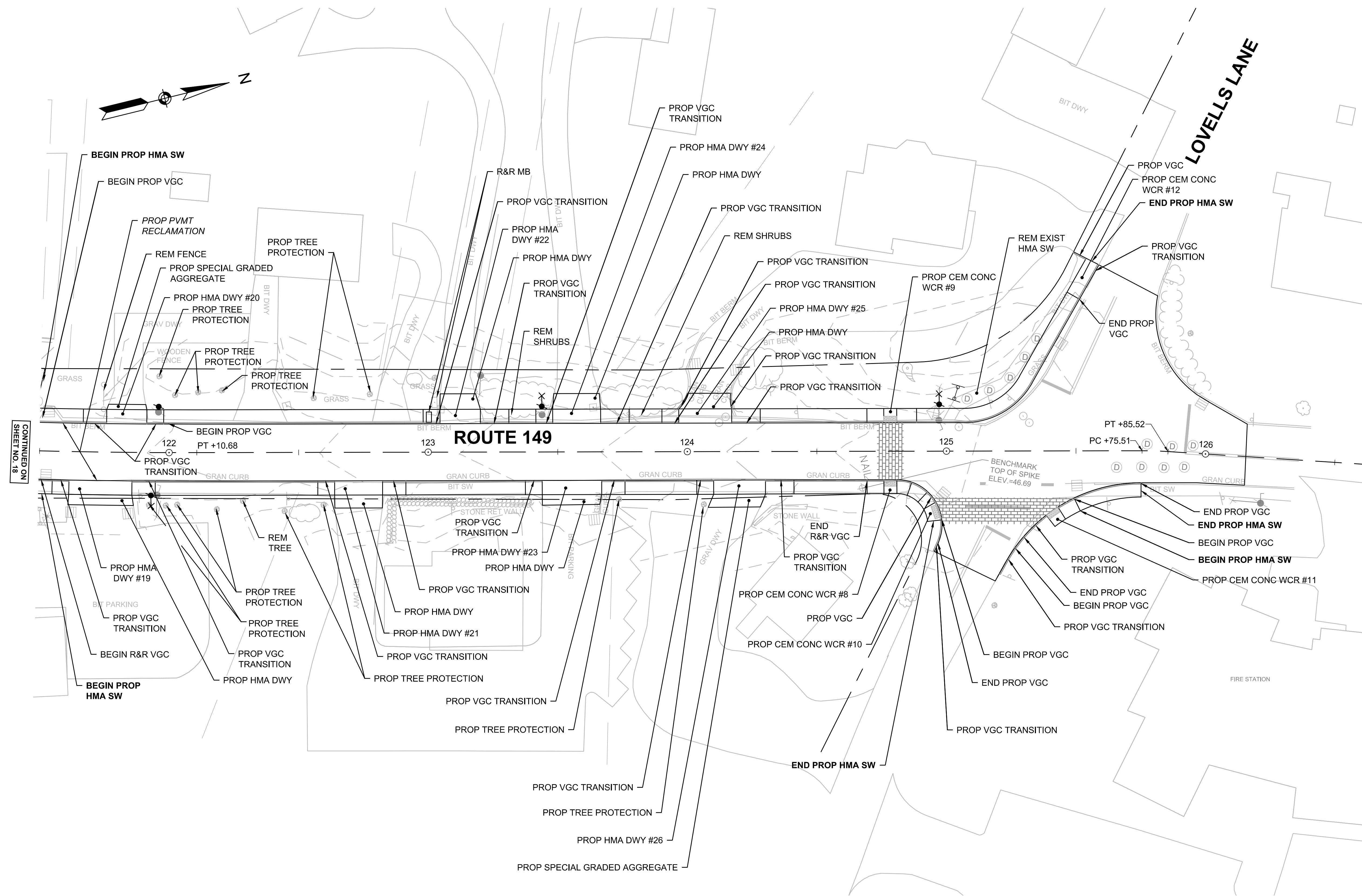

CONTINUED ON SHEET NO. 18

BARNSTABLE
MARSTONS MILLS VILLAGE CENTER IMPROVEMENTS

SHEET NO.	TOTAL SHEETS
20	109

CONSTRUCTION PLAN
SHEET 6 OF 8

REV #	DATE
△	3/13/19

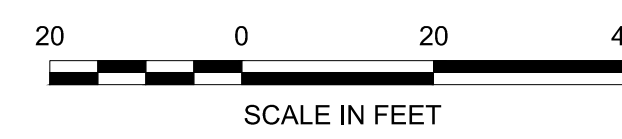
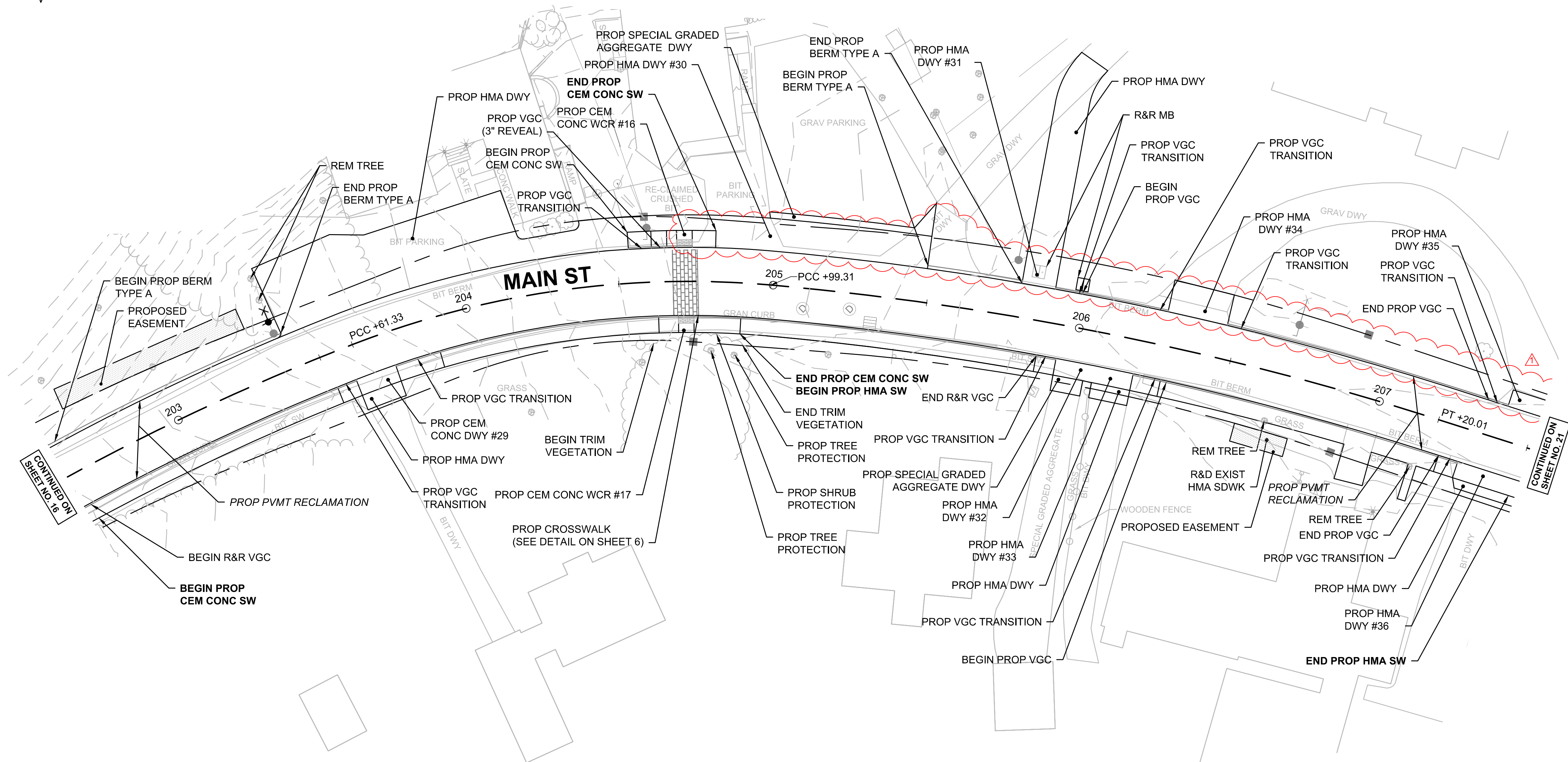
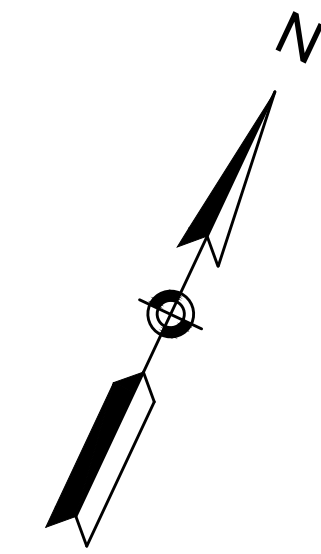

BARNSTABLE
MARSTONS MILLS VILLAGE CENTER IMPROVEMENTS

SHEET NO.	TOTAL SHEETS
22	109

CONSTRUCTION PLAN
SHEET 8 OF 8

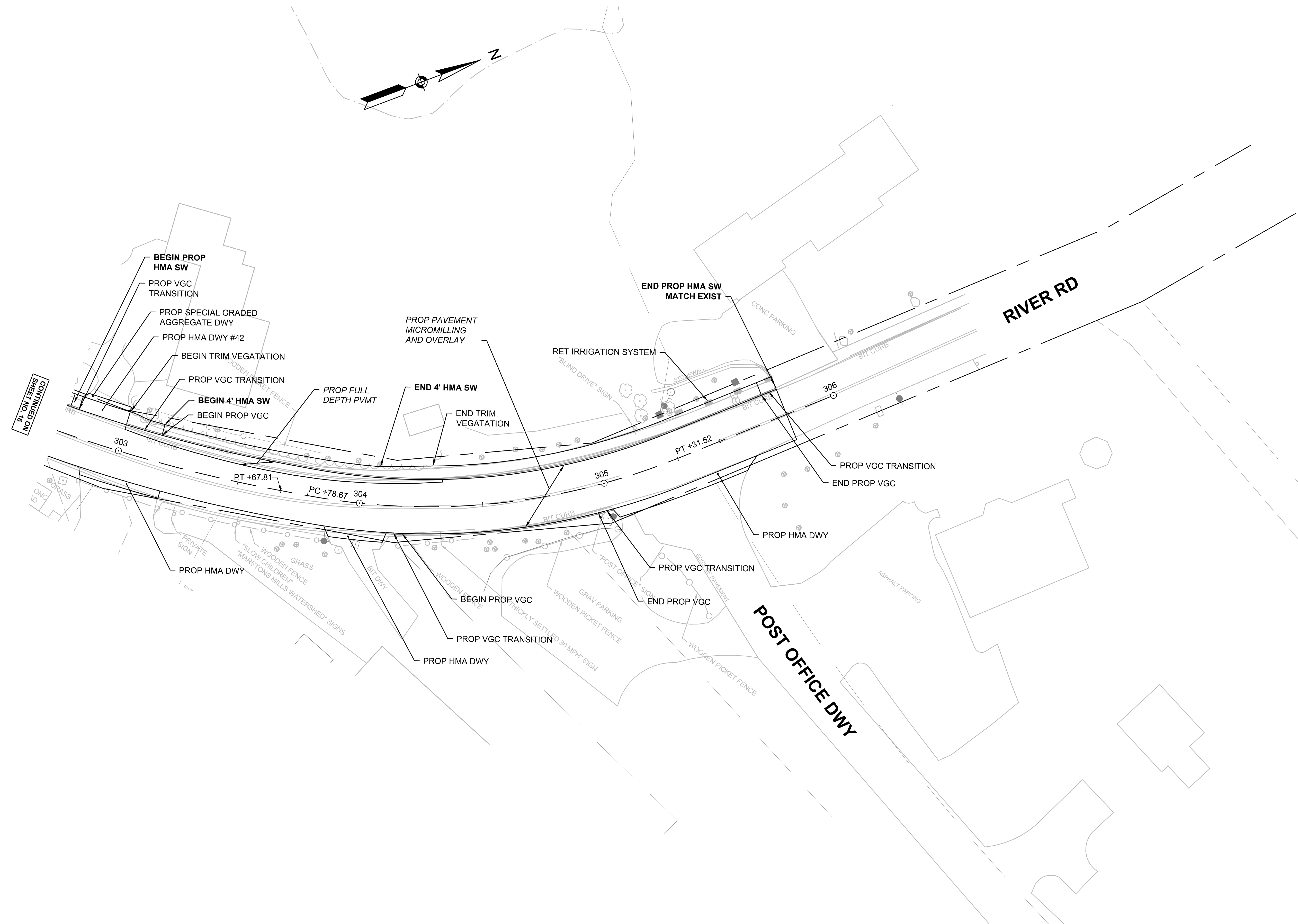

CONTINUED TO SHEET NO. 21

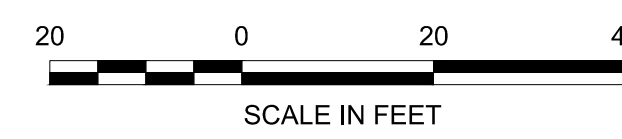

**BARNSTABLE
MARSTONS MILLS VILLAGE CENTER IMPROVEMENTS**

SHEET NO.	TOTAL SHEETS
23	108

**DRAINAGE & UTILITY PLANS (1)
SHEET 1 OF 8**

REV #	DATE
△	11/28/18

STRUCTURE SCHEDULE					
NAME	TYPE	RIM	INVERTS	STATION	OFFSET
CB 1.1	CATCH BASIN	20.22	12" INV OUT = 17.63 TO EX DMH	102+85.08	-17.22
CB 2.1	CATCH BASIN	25.74	12" INV OUT = 21.70 TO RB 2.1	105+26.25	-10.00
CB 2.2	CATCH BASIN	25.29	12" INV OUT = 22.74 TO RB 2.1	105+26.51	10.00
RB 2.1	6" DIAM. RECHARGE BASIN	25.65	12" INV IN = 21.65 FROM CB 2.1 12" INV IN = 22.60 FROM CB 2.2 12" INV OUT = 21.65 TO RB 2.2	105+32.23	2.49
RB 2.2	6" DIAM. RECHARGE BASIN	26.07	12" INV IN = 21.65 FROM RB 2.1 12" INV OUT = 21.70 TO EX. DMH2	105+43.82	2.39

PIPE SCHEDULE						
FROM	TO	SIZE	MATERIAL	LENGTH	SLOPE	
CB 1.1	EX DMH	12"	HDPE	4'	0.50%	△
CB 2.1	RB 2.1	12"	HDPE	9'	0.33%	
CB 2.2	RB 2.1	12"	HDPE	4'	1.49%	
RB 2.1	RB 2.2	12"	HDPE	6'	0.00%	
RB 2.2	EX. DMH2	12"	HDPE	7'	0.50%	

#71
ASSESSOR'S MAP: 077
PARCEL: 007
N/F
GLAVIN KEVIN A & JUDITH A
REF: 13949/077

#65
ASSESSOR'S MAP: 077
PARCEL: 022
N/F
MCCLUSKY ROBERT FRANK
& MIKOLS GENNS
REF: 21961254

#46
ASSESSOR'S MAP: 077
PARCEL: 024
N/F
SCHLOERB RONALD G
REF: 14860/122

#26
ASSESSOR'S MAP: 077
PARCEL: 024
N/F
BARNSTABLE LAND TRUST
REF: 8090/151

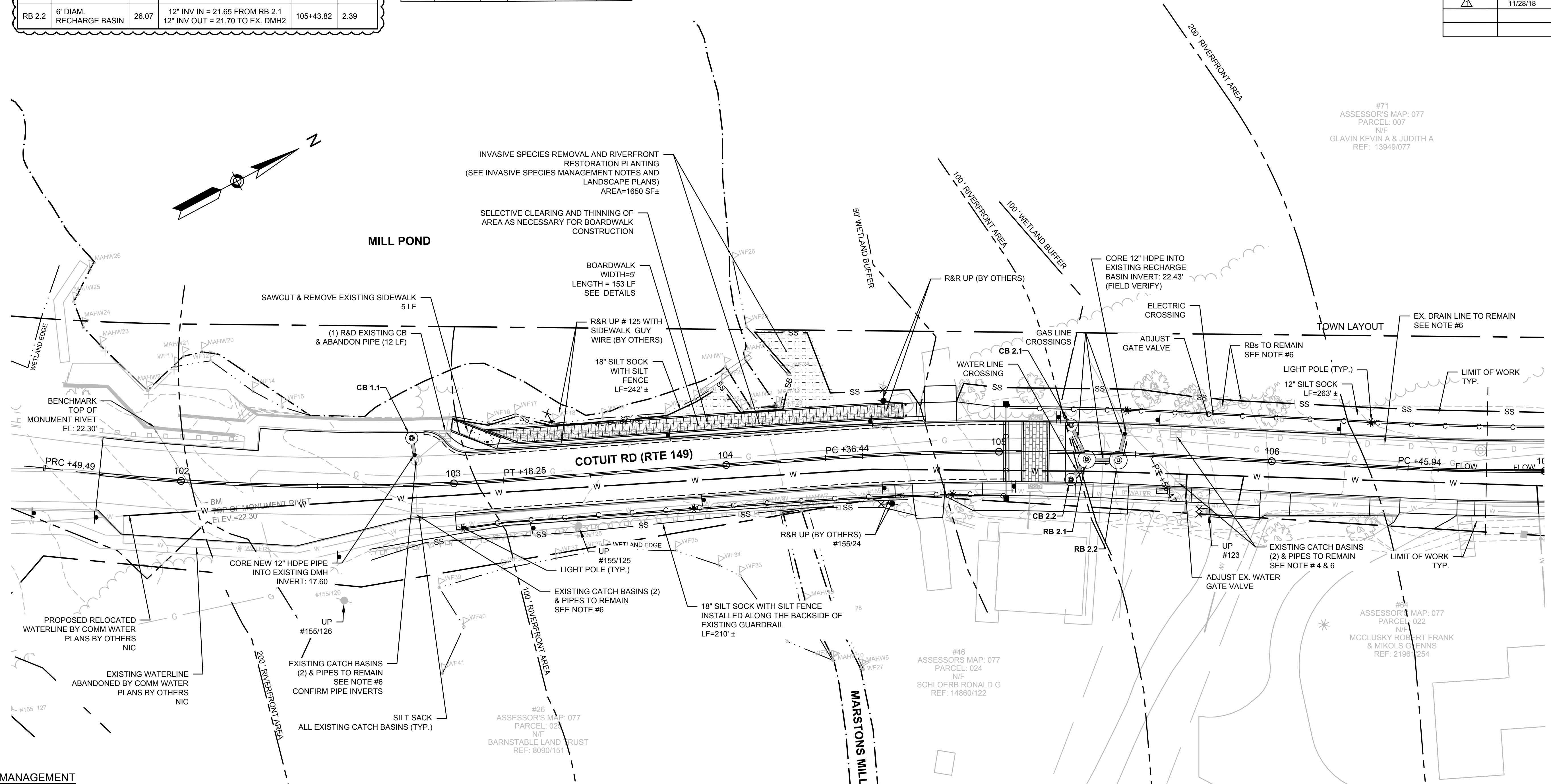

INVASIVE SPECIES MANAGEMENT

REMOVAL SEQUENCING

THE FOLLOWING CONSTRUCTION SEQUENCE IS TO BE USED AS A GENERAL GUIDELINE. THE CONTRACTOR TO COORDINATE WITH THE TOWN AND ENGINEERS AND SUBMIT A PROPOSED CONSTRUCTION SEQUENCE FOR REVIEW AND APPROVAL PRIOR TO CONSTRUCTION.

- IT IS ANTICIPATED THAT THE INVASIVE SPECIES REMOVAL WILL COMMENCE ONLY AFTER COMPLETION OF ALL SITE DEMOLITION AND PRIOR TO BOARDWALK CONSTRUCTION. THE ENGINEER MUST BE NOTIFIED OF ANY DEVIATION OF THIS PROCESS.
- EROSION AND SEDIMENTATION CONTROL MEASURES (E.G. STRAWBALE, SEDIMENT SOCK) SHOULD BE INSTALLED AS INDICATED ON THE PLANS PRIOR TO INVASIVE SPECIES REMOVAL.
- THE LANDSCAPE ARCHITECT OR BIOLOGIST WILL IDENTIFY INVASIVE SPECIES TO BE REMOVED.
- ONLY REMOVE LARGE TREES AS SHOWN ON THE PLANS OR AS IDENTIFIED IN THE FIELD BY THE LANDSCAPE ARCHITECT OR BIOLOGIST. REMOVE ALL STUMPS. ONLY GRIND STUMPS IF INVASIVE SPECIES ARE NOT WITHIN 10 FEET OF STUMP.
- CONDUCT REMOVAL OF INVASIVE SPECIES IN THE AREA OF BOARDWALK CONSTRUCTION AND POND SHORLINE RESTORATION AREA AS DESCRIBED BELOW.
- WASH ALL TOOLS, BUCKETS, AND MACHINERY THAT COMES IN CONTACT WITH INVASIVE SPECIES INFESTED SOIL. ALL WASHING TO OCCUR IN A LOCATION THAT DOES NOT DISCHARGE TOWARD THE PROJECT AREA.
- DISPOSE OF SOIL INFESTED WITH INVASIVE SPECIES. ALL INVASIVE SPECIES DEBRIS TO BE DISPOSED OF AT AN APPROVED LOCATION AS DESCRIBED IN THE SPECIFICATIONS.
- PREPARE THE SURFACE FOR PLANTING.
- INSTALL JUTE NETTING ON ANY SLOPES 3:1 OR GREATER. PLANT THE DISTURBED AREAS AS INDICATED ON THE LANDSCAPE PLAN.
- ALL PLANTINGS ARE TO BE MAINTAINED PER THE SPECIFICATIONS.

MANAGEMENT

- INVASIVE SPECIES MANAGEMENT SHOULD BE CUSTOMIZED TO THE INDIVIDUAL SPECIES FOLLOWING THE SPECIFIC MEASURES OUTLINED IN THE SPECIFICATION.
- MANUAL CONTROL: REMOVE PLANTS BY HAND TO A DEPTH OF APPROXIMATELY 2'. CAUTION MUST BE TAKEN TO ENSURE ALL ROOTS AND RUNNERS HAVE BEEN REMOVED. A HAND DIGGING TOOL SUCH AS A WEED WRENCH MAY BE USED.

GENERAL GRADING, DRAINAGE AND UTILITY NOTES

- ALL CUT AND FILL SLOPES SHALL BE 3:1 OR FLATTER UNLESS OTHERWISE NOTED.
- ADJUST AND/OR CUT EXISTING PAVEMENT AS NECESSARY TO ASSURE A SMOOTH FIT AND CONTINUOUS GRADE.
- PROVIDE POSITIVE DRAINAGE AWAY FROM BUILDINGS FOR ALL NATURAL AND PAVED AREAS. IMMEDIATELY NOTIFY THE ENGINEER IF POSITIVE DRAINAGE CANNOT BE PROVIDED.
- INSTALL CATCH BASIN INSERTS AT ALL EXISTING AND PROPOSED CATCH BASINS TO PROTECT DURING CONSTRUCTION.
- ALL GATE VALVE, CURB STOPS AND OTHER UTILITY COVERS AT THE SURFACE WITHIN THE LIMIT OF WORK ARE TO BE ADJUSTED TO THE PROPOSED FINISH GRADES.
- CONFIRM GAS LINE AND WATER LINE DEPTH AND LOCATION AT ALL DRAIN PIPE CROSSING PRIOR TO THE INSTALLATION OF DRAINAGE STRUCTURES. IMMEDIATELY NOTIFY ENGINEER OF ANY CONFLICTS.
- DRAIN PIPES TO CROSS BENEATH GAS LINE. PROVIDE A MINIMUM OF 6" OF SEPARATION BETWEEN BOTTOM OF GAS LINE AND TOP OF DRAIN PIPE AT ALL CROSSING.
- DRAIN PIPE TO CROSS ABOVE WATER LINES. PER COMM WATER, PROVIDE A MINIMUM OF 8-12" OF SEPARATION AT ALL WATER LINE CROSSING.
- CLEAN AND REMOVE SEDIMENT FROM ALL EXISTING STRUCTURES AND PIPES TO REMAIN.
- DO NOT PAVE ROADS AND PARKING AREAS UNTIL THE ENTIRE PERMANENT DRAINAGE SYSTEM HAS BEEN INSTALLED AND ALL PIPE CONNECTIONS COMPLETE. PAVING WILL NOT BE ALLOWED IF THE DRAINAGE SYSTEM FOR THE PROPOSED PAVED AREA IS NOT COMPLETELY AND PROPERLY INSTALLED. THIS INCLUDES THE STABILIZATION OF ALL DISTURBED AREAS CONTRIBUTING TO THE DRAINAGE SYSTEMS AND ANY STORMWATER BASIN FLOORS AND SIDE SLOPES.

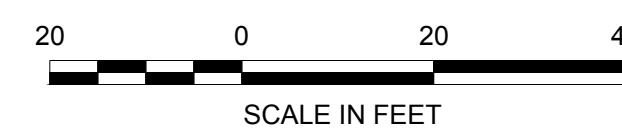

CONTINUED ON
SHEET NO. 24

**BARNSTABLE
MARSTONS MILLS VILLAGE CENTER IMPROVEMENTS**

SHEET NO.	TOTAL SHEETS
24	108

**DRAINAGE & UTILITY PLANS (2)
SHEET 2 OF 8**

REV #	DATE
△	11/28/18

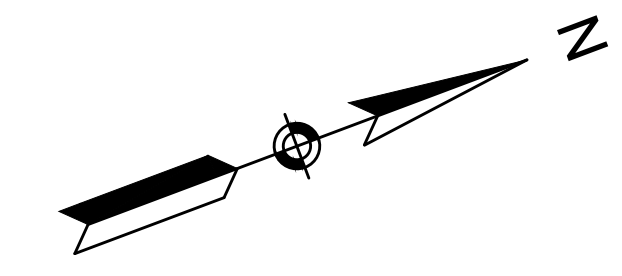

STRUCTURE SCHEDULE					
NAME	TYPE	RIM	INVERTS	STATION	OFFSET
CB 3.1	CATCH BASIN	30.24	8" INV OUT = 26.19 TO TREE TRENCH 1 12" INV OUT = 27.19 TO RB 3.1	108+35.05	10.00
CB 4.1	CATCH BASIN	31.70	12" INV OUT = 26.69 TO EX. RB	300+69.96	-11.08
CB 4.2	BIO OVERFLOW OUTLET	31.13	4" INV IN = 28.02 FROM BIO 2 12" INV OUT = 27.96 TO DMH 4.1	300+51.74	14.07
CB 4.3	CATCH BASIN	28.71	10" INV OUT = 27.00 TO EX. DMH5	109+69.80	-14.00
CB 5.1	CATCH BASIN	32.82	12" INV OUT = 29.82 TO RB 5.1	110+30.00	-10.00
CB 5.2	CATCH BASIN	32.86	12" INV OUT = 29.86 TO RB 5.1	110+30.00	8.00
CB 11.2	CATCH BASIN	38.30	12" INV OUT = 35.30 TO EX RB	201+12.57	-10.50
CB 11.4	BIO OVERFLOW OUTLET	31.35	4" INV IN = 28.24 FROM BIO 3 12" INV OUT = 28.19 TO DMH 11.2	109+47.76	27.21
CB 12.1	3' X 3' BOX INLET	35.28	12" INV OUT = 32.32 TO RB 12.1	302+36.00	-9.41
CB 12.2	CATCH BASIN	35.47	12" INV OUT = 32.32 TO RB 12.1	302+36.00	10.20
DMH 4.1	CONVERT CATCH BASIN TO MANHOLE	31.38	12" INV IN = 27.65 FROM CB 4.2 18" INV OUT = 27.10 TO EX. DMH5	300+49.94	-16.52
DMH 6.1	CONVERT CATCH BASIN TO MANHOLE	36.52	12" INV IN = 32.62 FROM CB 6.1 12" INV IN = 33.52 FROM CB 6.2 12" INV OUT = 32.62 TO EX. RB 13	112+45.21	8.77
DMH 11.2	CONVERT CATCH BASIN INTO MANHOLE	31.07	12" INV IN = 28.12 FROM CB 11.4 12" INV OUT = 28.12 TO EX. RB.	109+33.31	26.77
EX. DMH4	EX. DRAIN MANHOLE	30.30	12" INV IN = 26.00 FROM RB 3.1 12" INV IN = 26.17 FROM EX CB 24" INV IN = 24.45 FROM EX. DMH5 24" INV OUT = 24.43 TO EX. DMH3	108+30.88	-7.00

STRUCTURE SCHEDULE					
NAME	TYPE	RIM	INVERTS	STATION	OFFSET
EX. DMH5	EXISTING MANHOLE	31.89	10" INV IN = 26.90 FROM CB 4.3 18" INV IN = 26.93 FROM DMH 4.1 24" INV OUT = 26.58 TO EX. DMH4	109+74.55	-7.06
RB 3.1	RECHARGE BASIN	30.27	12" INV IN = 27.11 FROM CB 3.1 12" INV OUT = 27.24 TO EX. RB3 12" INV OUT = 26.08 TO EX. DMH4	108+23.11	-1.54
RB 5.1	RECHARGE BASIN	32.77	12" INV IN = 29.78 FROM CB 5.1 12" INV IN = 29.78 FROM CB 5.2 12" INV OUT = 30.28 TO RB 5.2	110+23.03	-6.37
RB 5.2	RECHARGE BASIN	32.62	12" INV IN = 30.21 FROM RB 5.1	110+14.40	-6.32
RB 6.1	RECHARGE BASIN	32.88	12" INV IN = 31.33 FROM EX. RB15 12" INV OUT = 31.33 TO RB 12.2	112+19.68	16.81
RB 6.2	RECHARGE BASIN	32.88	12" INV IN = 31.33 FROM RB 6.1 12" INV OUT = 31.33 TO RB 6.3	112+11.05	16.25
RB 6.3	RECHARGE BASIN	32.88	12" INV IN = 31.33 FROM RB 6.2	112+02.97	15.96
RB 12.1	RECHARGE BASIN	35.30	12" INV IN = 32.26 FROM CB 12.1 12" INV IN = 32.23 FROM CB 12.2 12" INV OUT = 32.00 TO RB 12.2	302+28.34	5.43
RB 12.2	RECHARGE BASIN	35.03	12" INV IN = 32.00 FROM RB 12.1 12" INV OUT = 32.00 TO RB 12.3	302+20.86	5.31
RB 12.3	RECHARGE BASIN	34.76	12" INV IN = 32.00 FROM RB 12.2 12" INV OUT = 32.00 TO RB 12.4	302+13.19	5.32
RB 12.4	RECHARGE BASIN	34.49	12" INV IN = 32.00 FROM RB 12.3	302+05.45	5.40

PIPE SCHEDULE					
FROM	TO	SIZE	MATERIAL	LENGTH	SLOPE
CB 3.1	RB 3.1	12"	HDPE	12'	0.50%
CB 3.1	TREE TRENCH 1	8"	HDPE	7'	0.87%
CB 4.1	EX. RB	12"	HDPE	15'	0.50%
CB 4.2	DMH 4.1	12"	HDPE	28'	1.01%
CB 4.3	EX. DMH5	10"	HDPE	4'	1.22%
CB 5.1	RB 5.1	12"	HDPE	3'	0.50%
CB 5.2	RB 5.1	12"	HDPE	11'	0.50%
CB 11.2	EX RB	12"	HDPE	11'	0.50%
CB 11.4	DMH 11.2	12"	HDPE	11'	0.50%
CB 12.1	RB 12.1	12"	HDPE	12'	0.39%

PIPE SCHEDULE					
FROM	TO	SIZE	MATERIAL	LENGTH	SLOPE
CB 12.2	RB 12.1	12"	HDPE	4'	0.93%
DMH 6.1	EX. RB 13	12"	HDPE	7'	0.50%
DMH 11.2	EX. RB.	12"	HDPE	29'	1.56%
RB 3.1	EX. RB3	12"	HDPE	50'	0.50%
RB 3.1	EX. DMH4	12"	HDPE	4'	0.87%
RB 5.1	RB 5.2	12"	HDPE	3'	0.77%
RB 12.1	RB 12.2	12"	HDPE	2'	0.00%
RB 12.2	RB 12.3	12"	HDPE	2'	0.00%
RB 12.3	RB 12.4	12"	HDPE	2'	0.00%

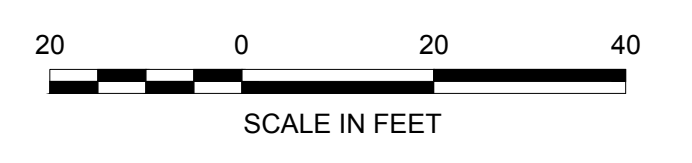
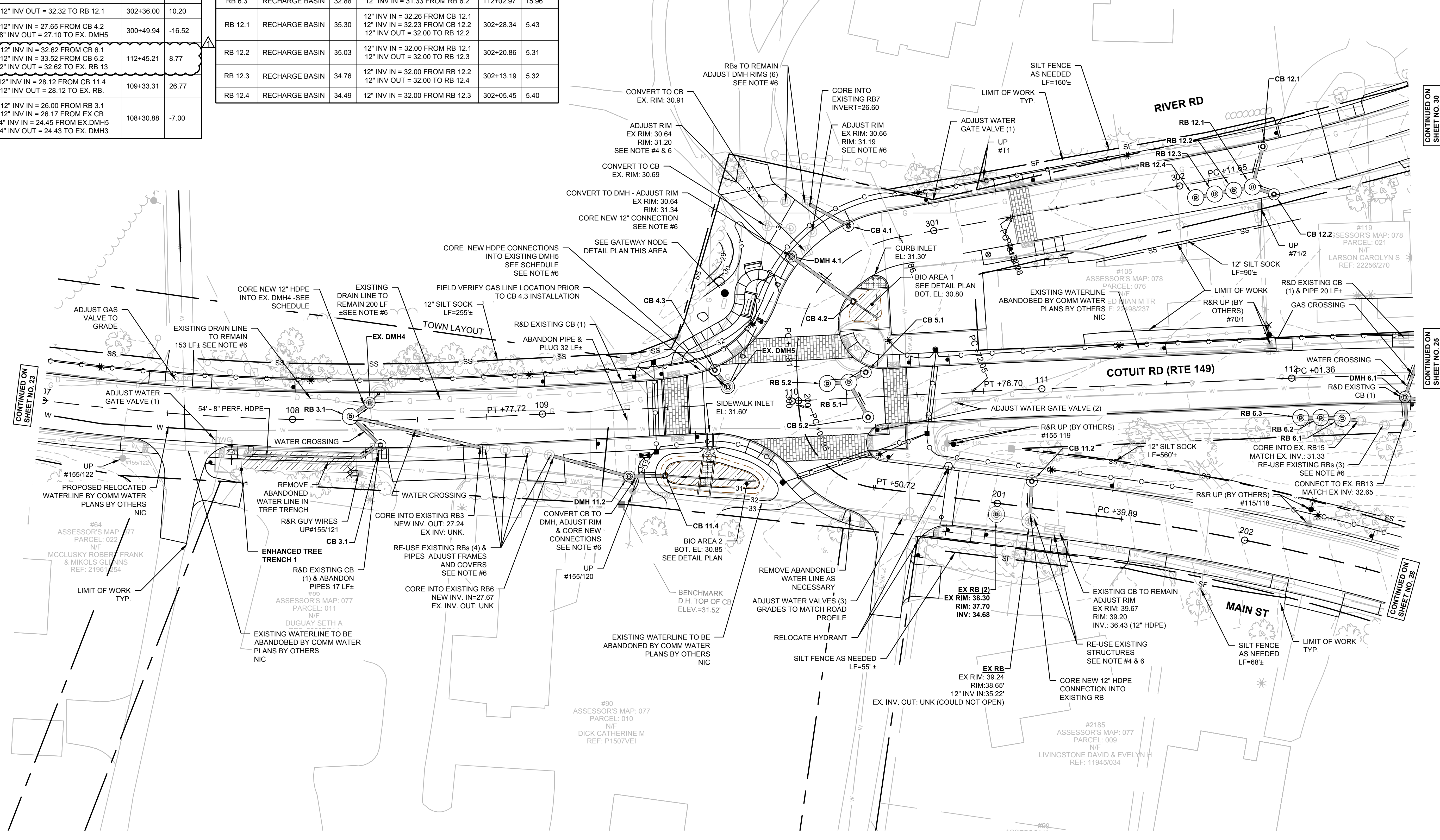

CONTINUED ON SHEET NO. 23

CONTINUED ON SHEET NO. 30

CONTINUED ON SHEET NO. 25

CONTINUED ON SHEET NO. 28

BARNSTABLE
MARSTONS MILLS VILLAGE CENTER IMPROVEMENTS

SHEET NO.	TOTAL SHEETS
25	108

DRAINAGE & UTILITY PLANS (3)
SHEET 3 OF 8

REV #	DATE
△	11/28/18

STRUCTURE SCHEDULE					
NAME	TYPE	RIM	INVERTS	STATION	OFFSET
CB 6.1	CATCH BASIN	36.57	12" INV OUT = 32.72 TO DMH 6.1	112+51.97	-10.00
CB 6.2	CATCH BASIN	36.57	12" INV OUT = 33.55 TO DMH 6.1 8" INV OUT = 32.55 TO TREE TRENCH 2	112+51.97	10.00
CB 7.1	CATCH BASIN	37.65	12" INV OUT = 33.70 TO RB 7.1 8" INV OUT = 33.60 TO TREE TRENCH 3	114+92.65	-10.00
CB 7.2	CATCH BASIN	37.65	12" INV OUT = 34.60 TO RB 7.1 8" INV OUT = 33.60 TO TREE TRENCH 4	114+92.65	10.00
RB 7.1	RECHARGE BASIN	37.82	12" INV IN = 33.66 FROM CB 7.1 12" INV IN = 34.54 FROM CB 7.2 12" INV OUT = 34.28 TO RB 7.2	114+96.77	-2.25
RB 7.2	RECHARGE BASIN	37.85	12" INV IN = 34.28 FROM RB 7.1	115+07.26	-2.35

PIPE SCHEDULE						
FROM	TO	SIZE	MATERIAL	LENGTH	SLOPE	
CB 6.1	DMH 6.1	12"	HDPE	16'	0.50%	△
CB 6.2	TREE TRENCH 2	8"	HDPE	10'	0.54%	△
CB 7.1	RB 7.1	12"	HDPE	4'	0.50%	△
CB 7.1	TREE TRENCH 3	8"	HDPE	1'	0.41%	
CB 7.2	RB 7.1	12"	HDPE	8'	0.50%	
CB 7.2	TREE TRENCH 4	8"	HDPE	2'	1.30%	
RB 7.1	RB 7.2	12"	HDPE	4'	0.00%	

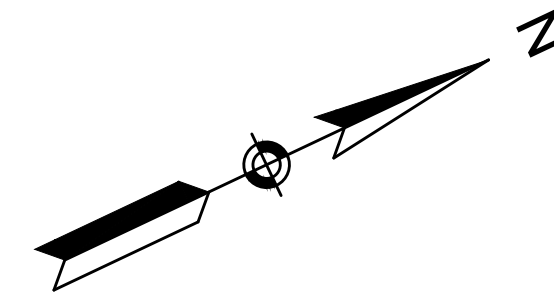

#159
ASSESSOR'S MAP: 078
PARCEL: 019
N/F
MAHAIRAS NICK I &
ROBIN H TRS
REF: 12824/158

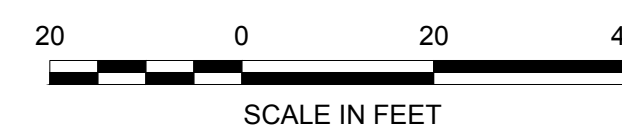
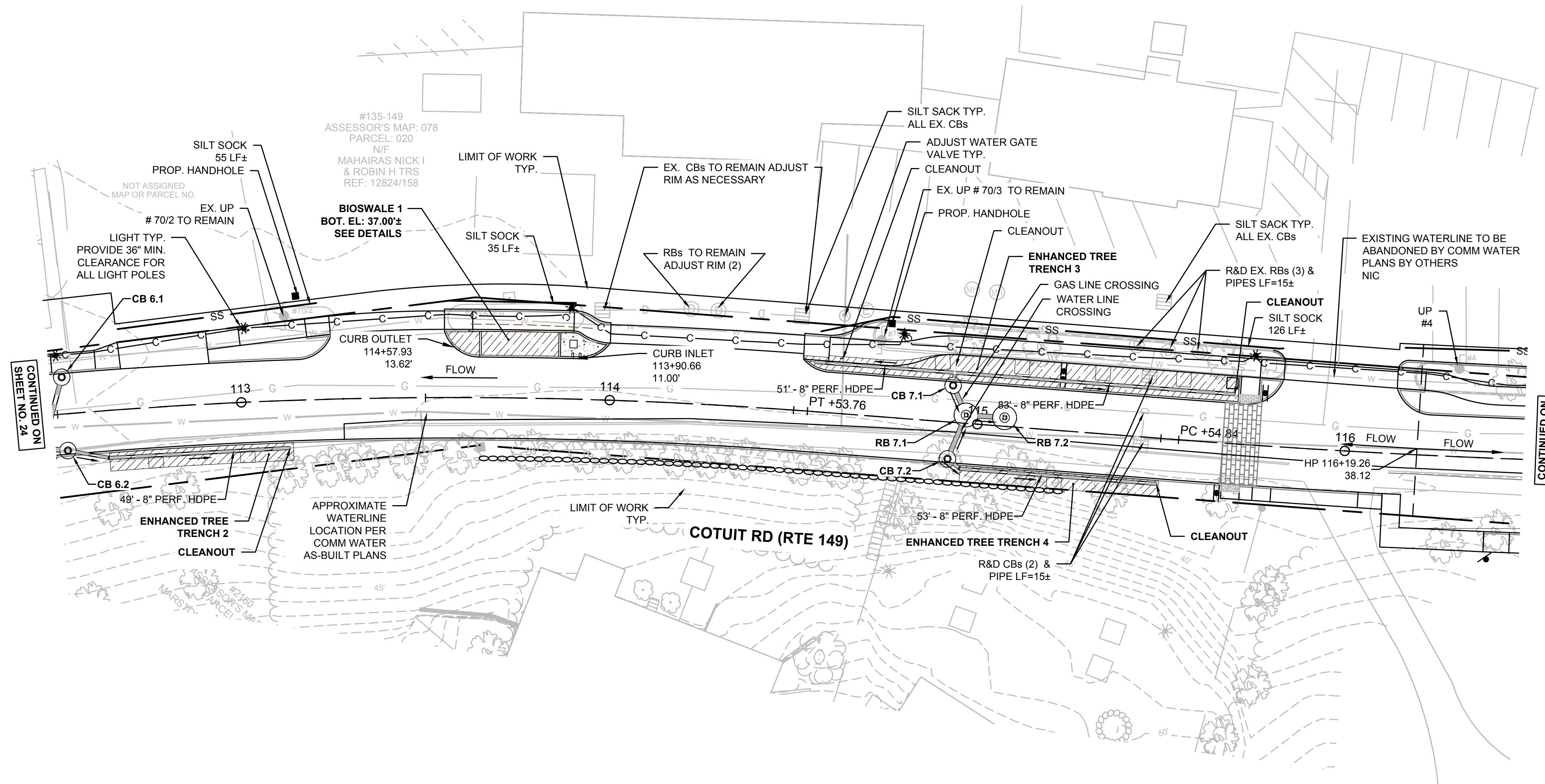

#55

CONTINUED ON SHEET NO. 24

CONTINUED ON SHEET NO. 26

**BARNSTABLE
MARSTONS MILLS VILLAGE CENTER IMPROVEMENTS**

SHEET NO.	TOTAL SHEETS
26	108

**DRAINAGE & UTILITY PLANS (4)
SHEET 4 OF 8**

REV #	DATE
△	11/28/18

STRUCTURE SCHEDULE					
NAME	TYPE	RIM	INVERTS	STATION	OFFSET
CB 8.1	CATCH BASIN	37.40	12" INV OUT = 34.35 TO RB 8.1 8" INV OUT = 33.45 TO TREE TRENCH 5	118+42.00	-10.00
CB 8.2	CATCH BASIN	37.40	12" INV OUT = 34.35 TO RB 8.4	118+42.00	10.00
CB 9.1	CATCH BASIN	39.06	12" INV OUT = 36.30 TO RB 9.1	120+57.64	-10.00
CB 9.2	CATCH BASIN	39.06	12" INV OUT = 35.10 TO RB 9.1	120+57.64	10.00
RB 8.1	RECHARGE BASIN	36.15	12" INV IN = 34.27 FROM CB 8.1 12" INV OUT = 34.27 TO RB 8.2	118+49.31	-7.00
RB 8.2	RECHARGE BASIN	36.15	12" INV IN = 34.27 FROM RB 8.1 12" INV OUT = 34.27 TO RB 8.3	118+56.60	-7.00
RB 8.3	RECHARGE BASIN	36.15	12" INV IN = 34.27 FROM RB 8.2	118+63.86	-7.00
RB 8.4	RECHARGE BASIN	37.47	12" INV IN = 34.31 FROM CB 8.2 12" INV OUT = 34.31 TO RB 8.5	118+33.69	7.00
RB 8.5	RECHARGE BASIN	37.48	12" INV IN = 34.31 FROM RB 8.4	118+25.96	7.00
RB 9.1	RECHARGE BASIN	39.25	12" INV IN = 36.16 FROM CB 9.1 12" INV IN = 34.99 FROM CB 9.2 12" INV OUT = 35.40 TO RB 9.2	120+70.96	-7.00
RB 9.2	RECHARGE BASIN	39.32	12" INV IN = 35.40 FROM RB 9.1 12" INV OUT = 35.40 TO RB 9.3	120+78.70	-7.00
RB 9.3	RECHARGE BASIN	39.39	12" INV IN = 35.40 FROM RB 9.2	120+86.66	-7.00

PIPE SCHEDULE					
FROM	TO	SIZE	MATERIAL	LENGTH	SLOPE
CB 8.1	TREE TRENCH 5	8"	HDPE	8'	2.00%
CB 8.1	RB 8.1	12"	HDPE	3'	1.01%
CB 8.2	RB 8.4	12"	HDPE	4'	0.50%
CB 9.1	RB 9.1	12"	HDPE	9'	1.00%
CB 9.2	RB 9.1	12"	HDPE	17'	0.50%
RB 8.1	RB 8.2	12"	HDPE	1'	0.00%
RB 8.2	RB 8.3	12"	HDPE	1'	0.00%
RB 8.4	RB 8.5	12"	HDPE	2'	0.00%
RB 9.1	RB 9.2	12"	HDPE	2'	0.00%
RB 9.2	RB 9.3	12"	HDPE	2'	0.00%

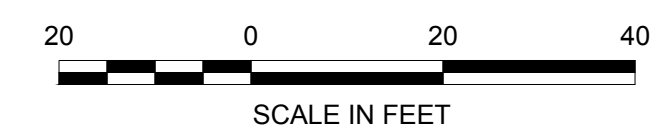
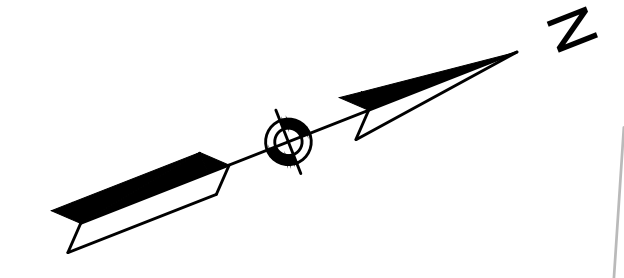
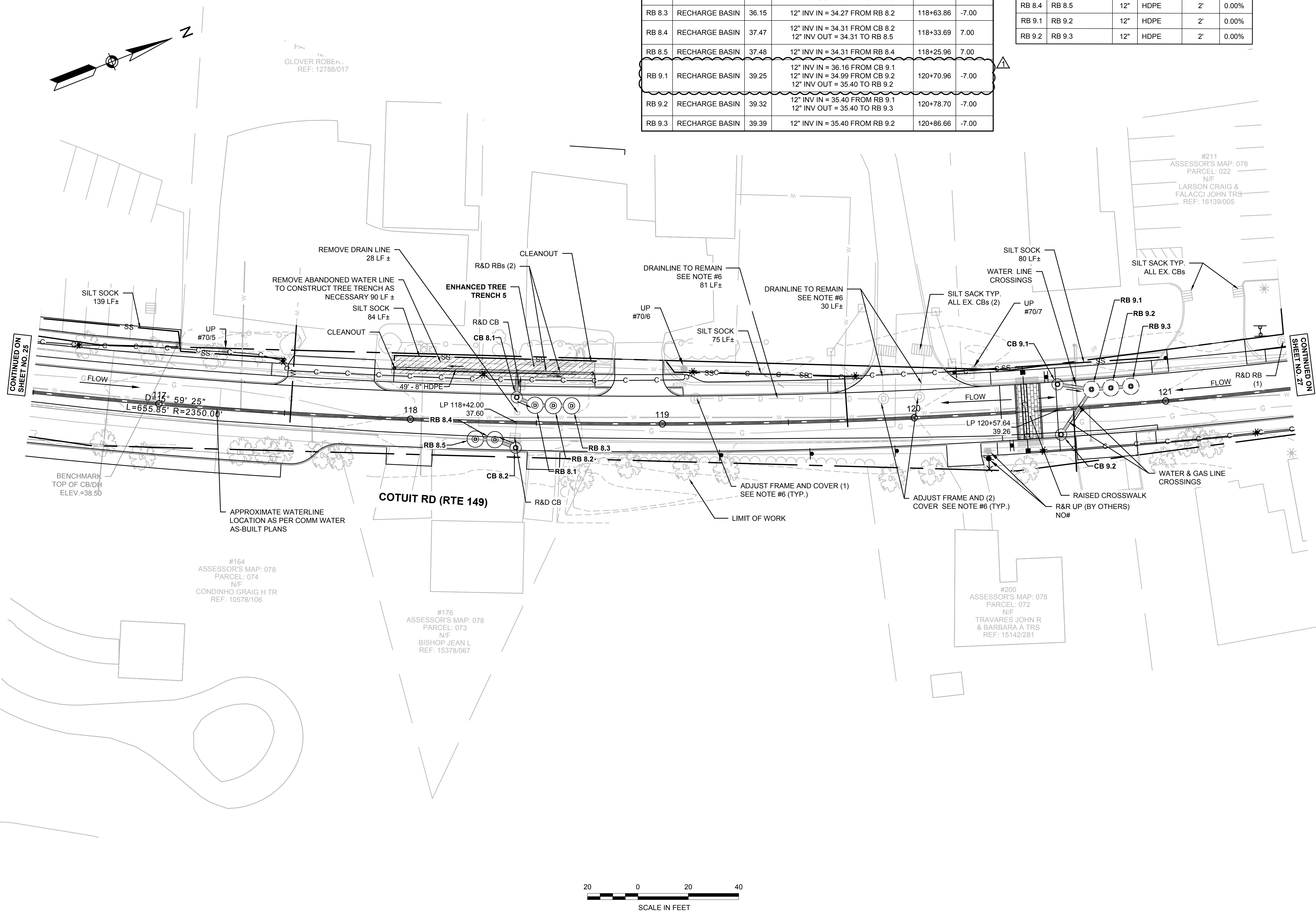

last modified: 11/28/18 printed: 11/28/18 by bk 13024-SW-DOT.DWG 28-Nov-2018

BARNSTABLE
MARSTONS MILLS VILLAGE CENTER IMPROVEMENTS

SHEET NO.	TOTAL SHEETS
27	108

DRAINAGE & UTILITY PLANS (5)
SHEET 5 OF 8

REV #	DATE
△	11/28/18

STRUCTURE SCHEDULE					
NAME	TYPE	RIM	INVERTS	STATION	OFFSET
CB 10.1	CATCH BASIN	40.63	12" INV OUT = 37.60 TO RB 10.1	122+00.00	-10.00
CB 10.2	CATCH BASIN	40.63	12" INV OUT = 36.60 TO RB 10.1	122+00.00	10.00
RB 10.1	RECHARGE BASIN	40.70	12" INV IN = 37.51 FROM CB 10.1 12" INV IN = 36.53 FROM CB 10.2 12" INV OUT = 37.00 TO RB 10.2	121+94.84	-3.00
RB 10.2	RECHARGE BASIN	40.58	12" INV IN = 37.00 FROM RB 10.1 12" INV OUT = 37.00 TO RB 10.3	121+86.66	-3.00
RB 10.3	RECHARGE BASIN	40.48	12" INV IN = 37.00 FROM RB 10.2 12" INV OUT = 37.00 TO RB 10.4	121+78.94	-3.00
RB 10.4	RECHARGE BASIN	40.37	12" INV IN = 37.00 FROM RB 10.3	121+71.22	-3.00

PIPE SCHEDULE					
FROM	TO	SIZE	MATERIAL	LENGTH	SLOPE
CB 10.1	RB 10.1	12"	HDPE	4'	1.00%
CB 10.2	RB 10.1	12"	HDPE	9'	0.50%
RB 10.1	RB 10.2	12"	HDPE	2'	0.00%
RB 10.2	RB 10.3	12"	HDPE	2'	0.00%
RB 10.3	RB 10.4	12"	HDPE	2'	0.00%

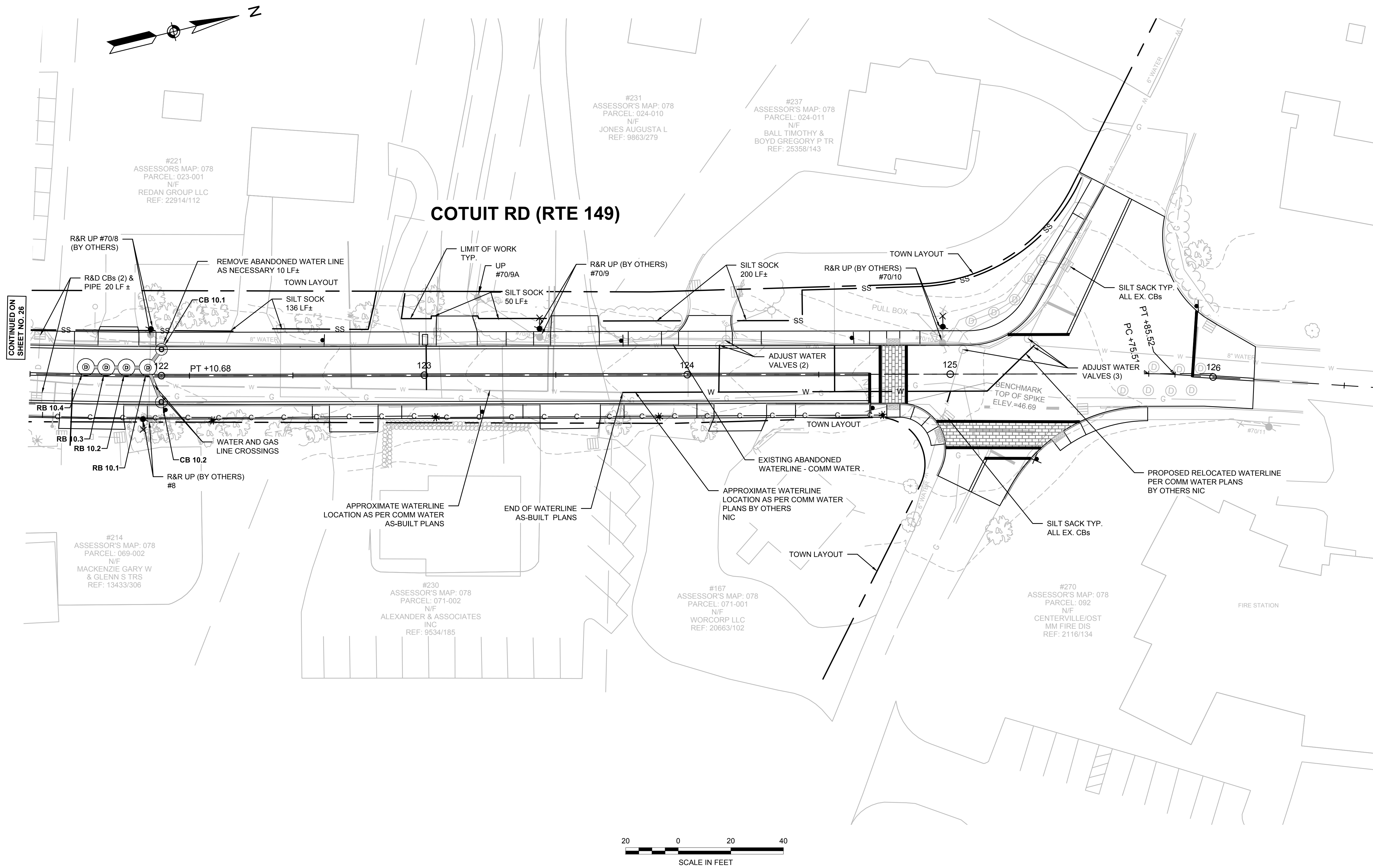

BARNSTABLE
MARSTONS MILLS VILLAGE CENTER IMPROVEMENTS

SHEET NO.	TOTAL SHEETS
28	108

DRAINAGE & UTILITY PLANS (6)
SHEET 6 OF 8

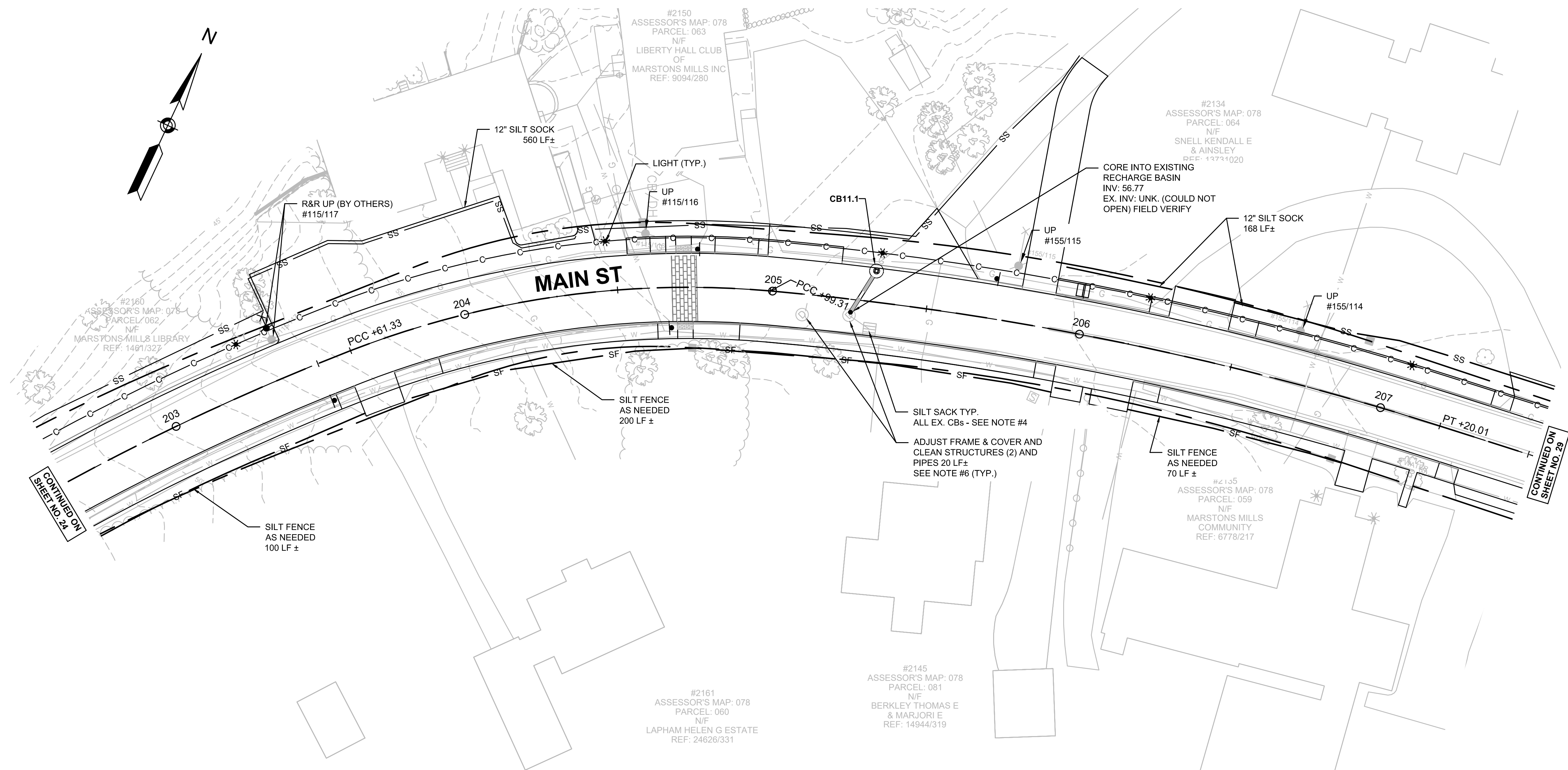

STRUCTURE SCHEDULE					
NAME	TYPE	RIM	INVERTS	STATION	OFFSET
CB11.1	CATCH BASIN	60.56	12" INV OUT = 56.85 TO EX RB1	205+32.54	-10.00

PIPE SCHEDULE					
FROM	TO	SIZE	MATERIAL	LENGTH	SLOPE
CB11.1	EX RB1	12"	HDPE	14'	0.50%

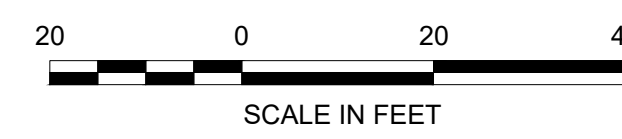

CONTINUED ON
SEE SHEET NO. 2A

CONTINUED ON
SEE SHEET NO. 2B

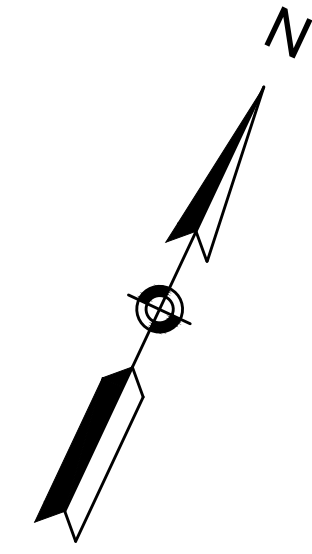

BARNSTABLE
MARSTONS MILLS VILLAGE CENTER IMPROVEMENTS

SHEET NO.	TOTAL SHEETS
29	108

DRAINAGE & UTILITY PLANS (7)
SHEET 7 OF 8

STRUCTURE SCHEDULE					
NAME	TYPE	RIM	INVERTS	STATION	OFFSET
CB 11.0	CATCH BASIN	63.52	12" INV OUT = 60.50 TO RB-11.3	211+28.55	-10.00
RB-11.3	RECHARGE BASIN	62.34	12" INV IN = 60.45 FROM CB 11.0	211+36.25	-5.50

PIPE SCHEDULE					
FROM	TO	SIZE	MATERIAL	LENGTH	SLOPE
CB 11.0	RB-11.3	12"	HDPE	4'	0.50%

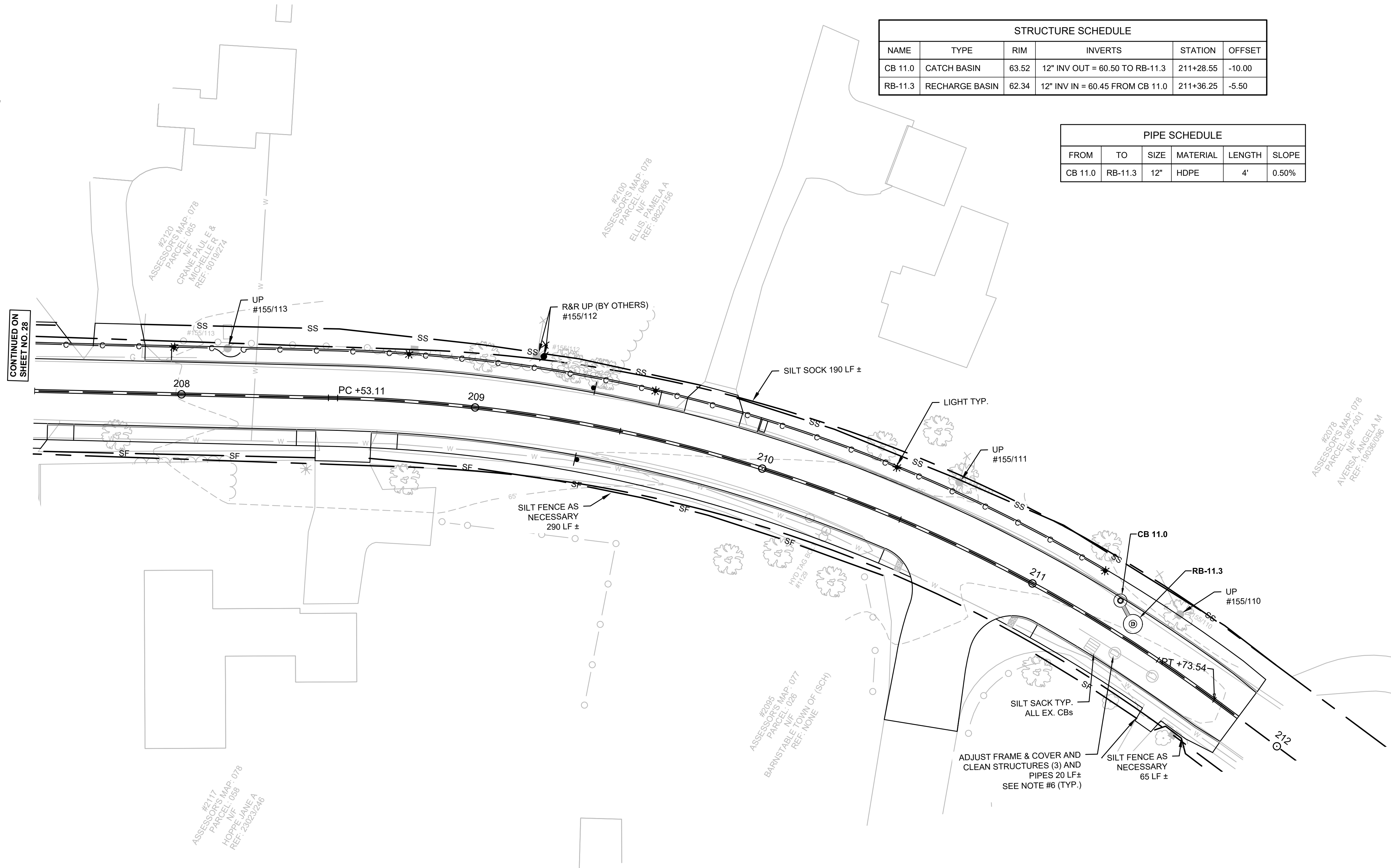
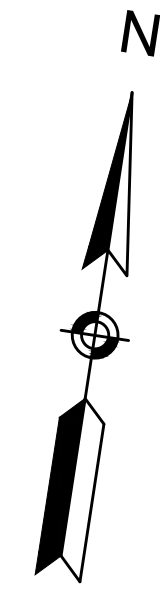

CONTINUED ON
SHEET NO. 28

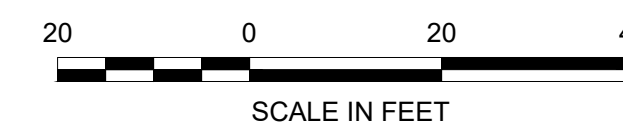

BARNSTABLE
MARSTONS MILLS VILLAGE CENTER IMPROVEMENTS

SHEET NO.	TOTAL SHEETS
30	108

DRAINAGE & UTILITY PLANS (8)
SHEET 8 OF 8

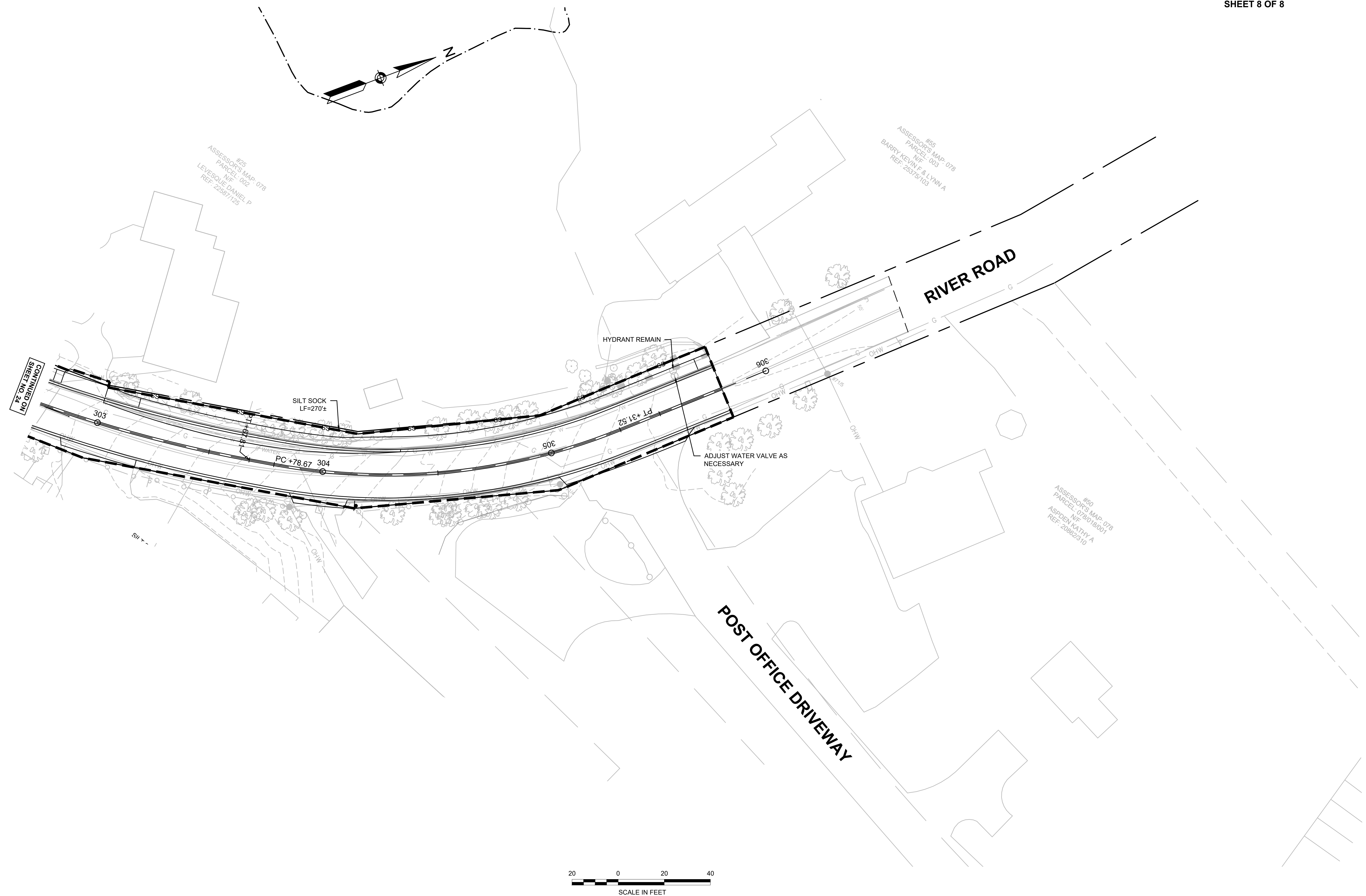

**BARNSTABLE
MARSTONS MILLS VILLAGE CENTER IMPROVEMENTS**

SHEET NO.	TOTAL SHEETS
31	109

**PROFILE SHEET 1 OF 8
ROUTE 149**

REV #	DATE
△	11/28/18

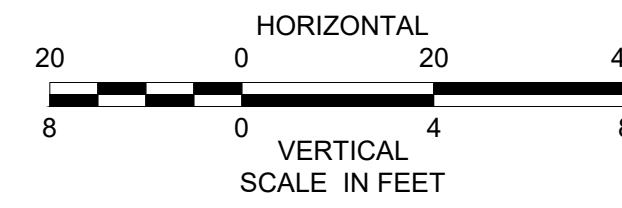
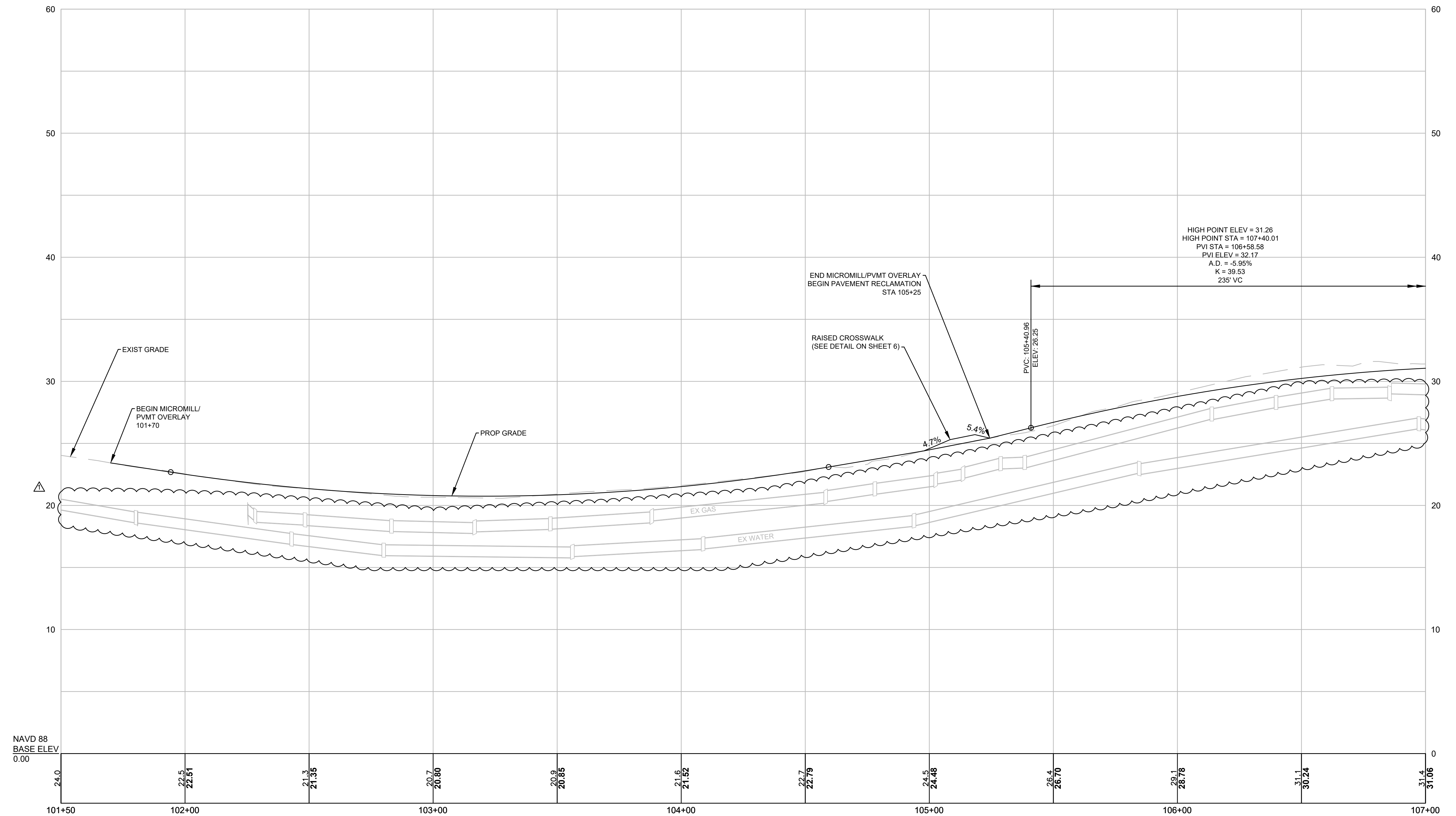

BARNSTABLE
MARSTONS MILLS VILLAGE CENTER IMPROVEMENTS

SHEET NO.	TOTAL SHEETS
32	109

PROFILE SHEET 2 OF 8
ROUTE 149

REV #	DATE
△	11/28/18

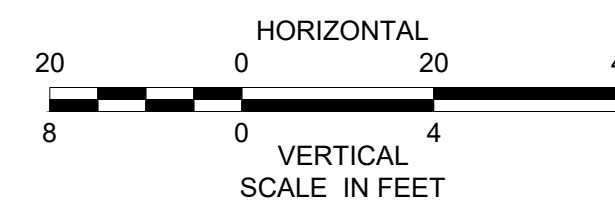
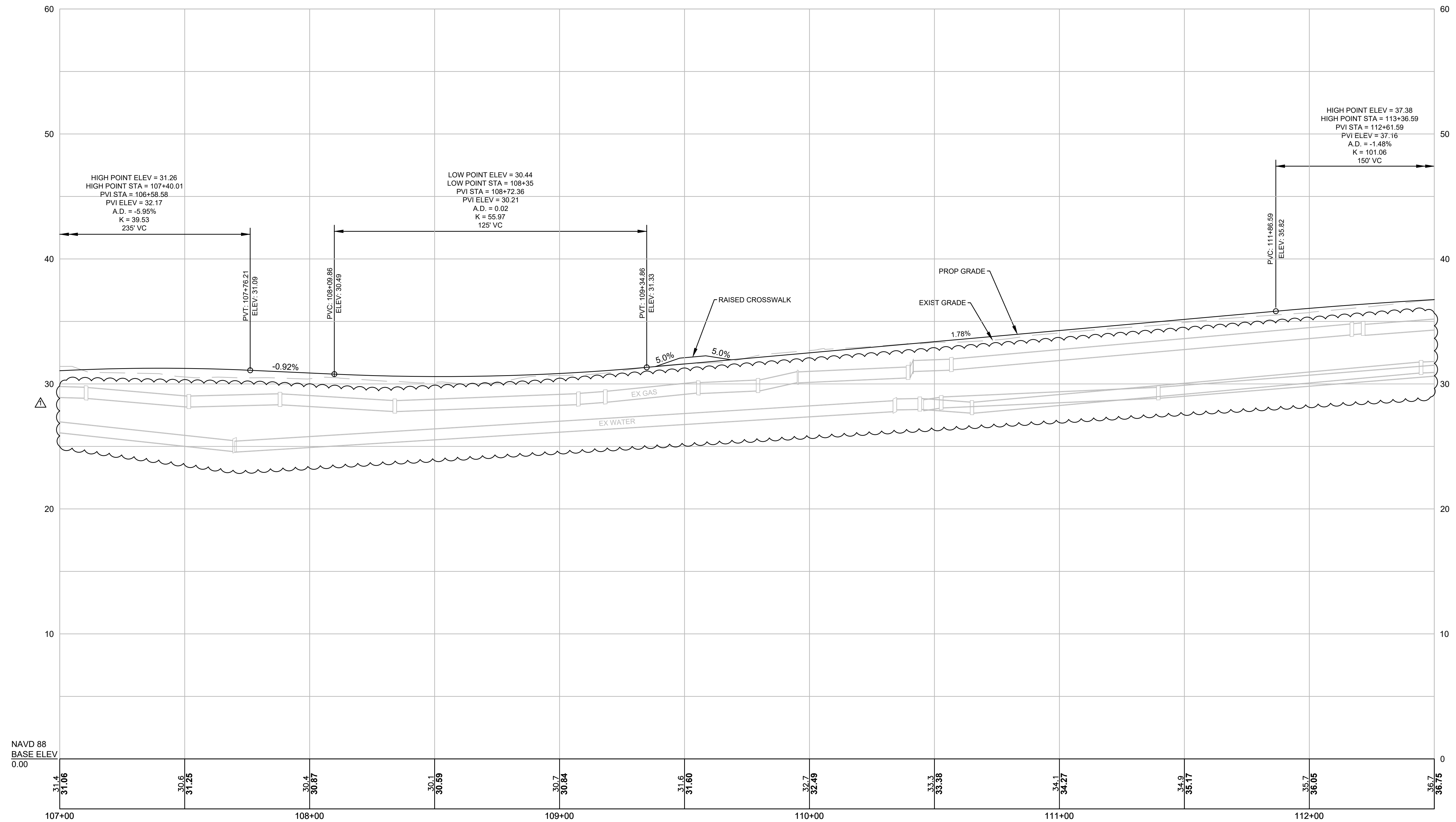

BARNSTABLE
MARSTONS MILLS VILLAGE CENTER IMPROVEMENTS

SHEET NO.	TOTAL SHEETS
33	109

PROFILE SHEET 3 OF 8
ROUTE 149

REV #	DATE
1	11/28/18

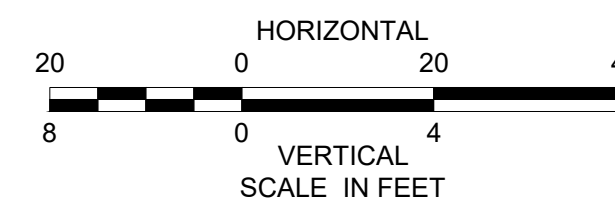
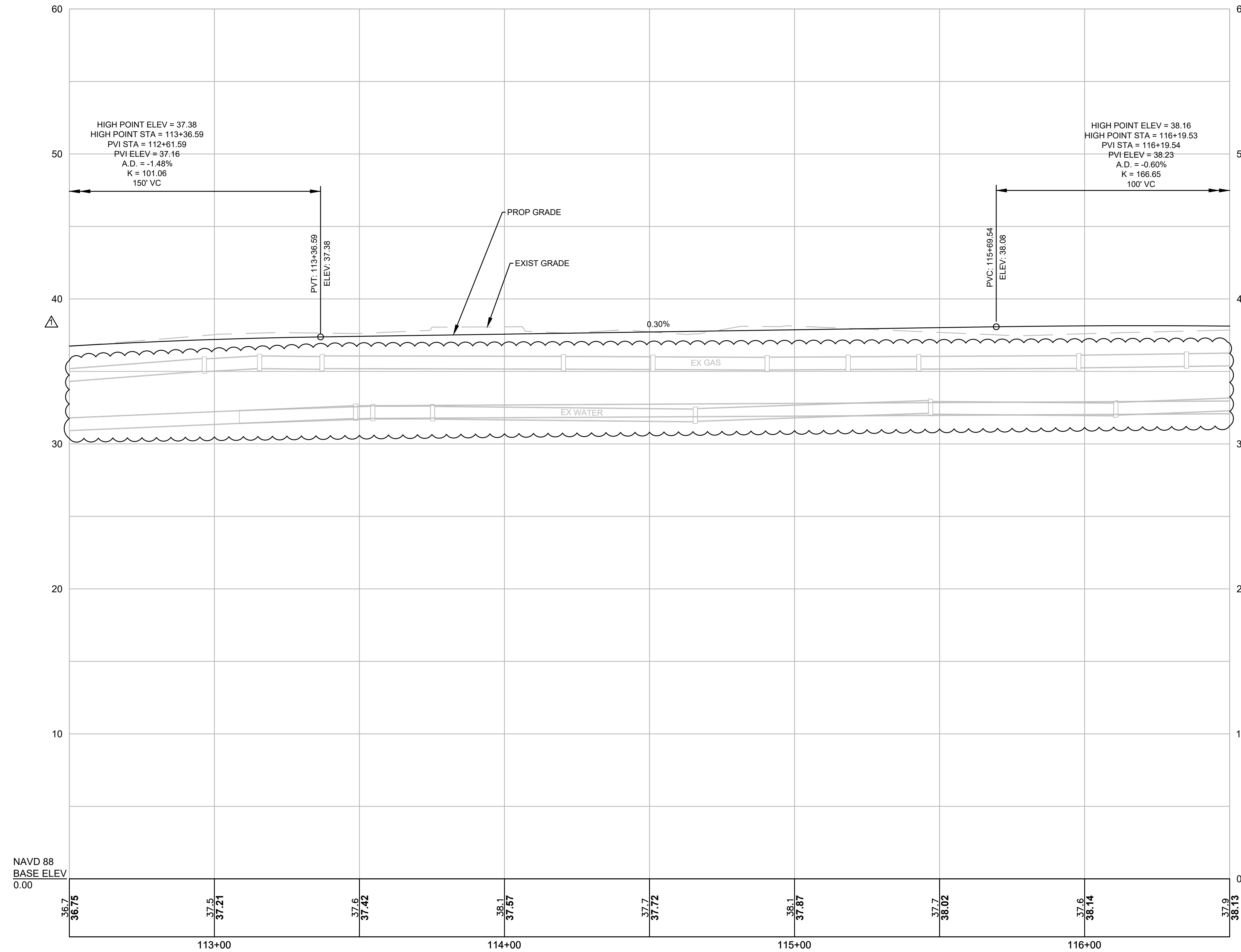

BARNSTABLE
MARSTONS MILLS VILLAGE CENTER IMPROVEMENTS

SHEET NO.	TOTAL SHEETS
34	109

PROFILE SHEET 4 OF 8
ROUTE 149

REV #	DATE
1	11/28/18

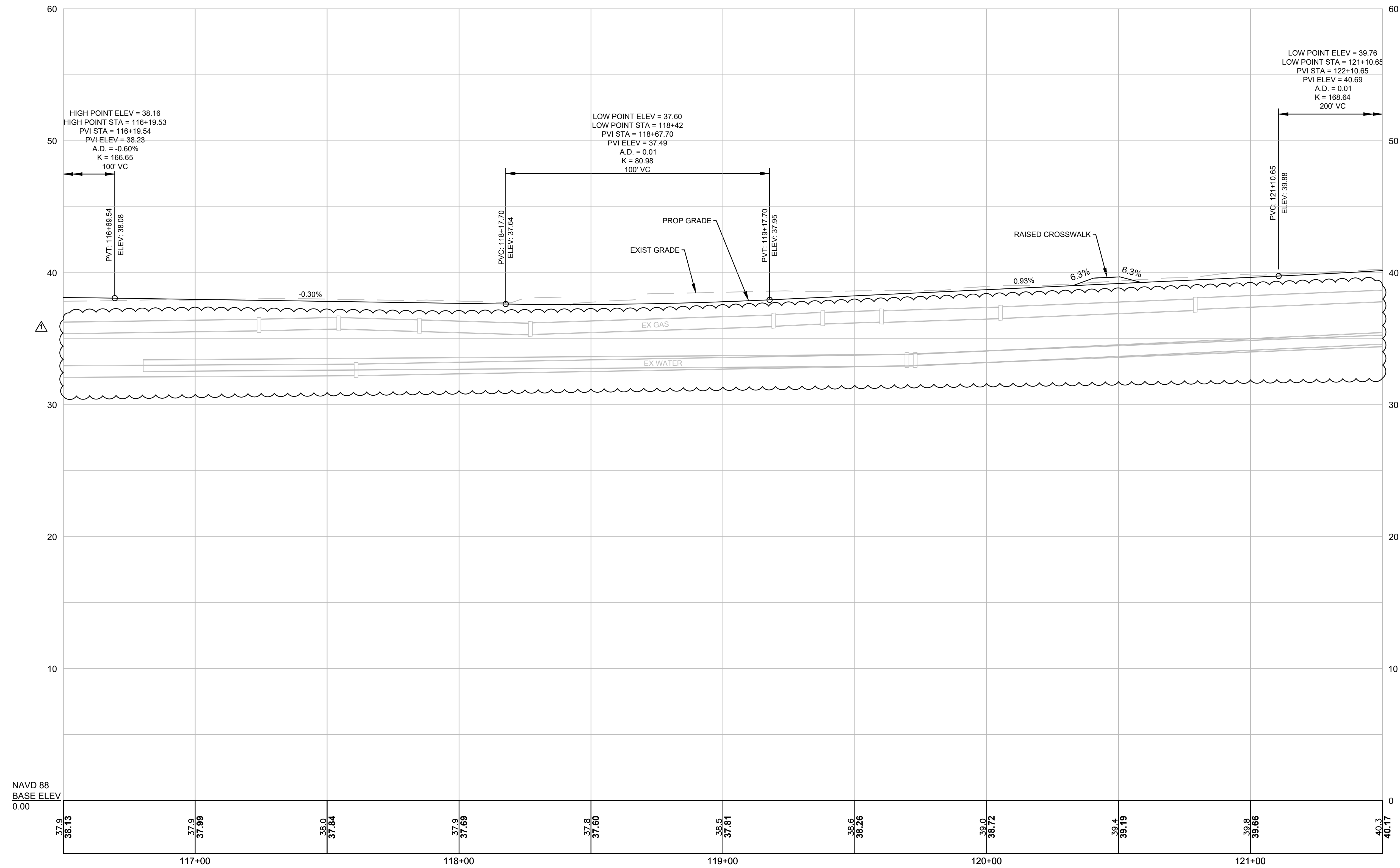

NAVD 88
BASE ELEV
0.00

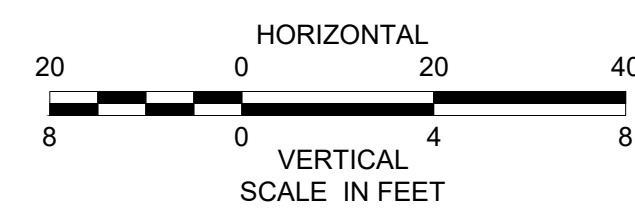

**BARNSTABLE
MARSTONS MILLS VILLAGE CENTER IMPROVEMENTS**

SHEET NO.	TOTAL SHEETS
35	109

**PROFILE SHEET 5 OF 8
ROUTE 149**

REV #	DATE
△	11/28/18

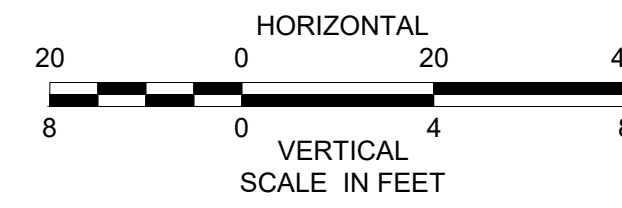
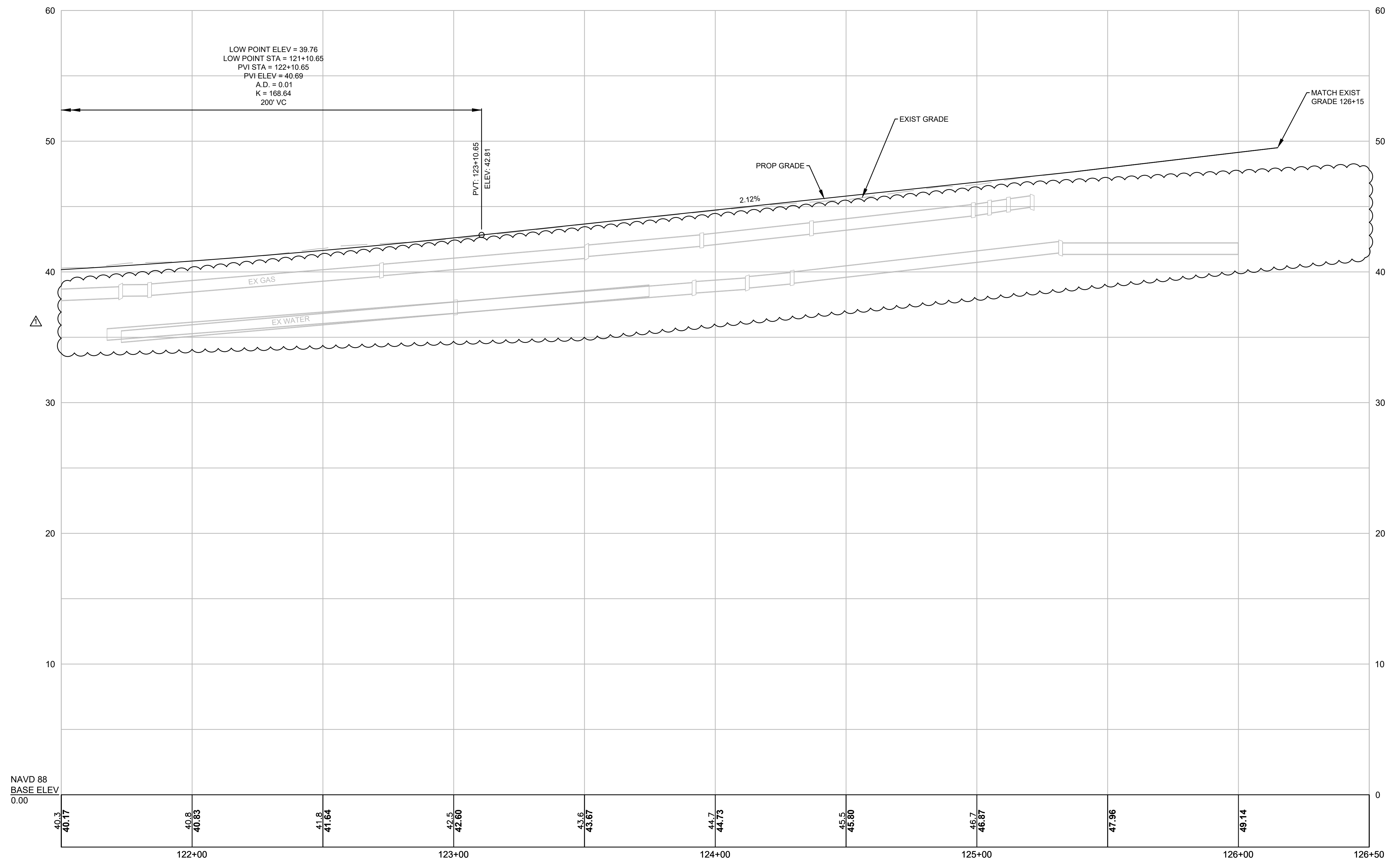

BARNSTABLE
MARSTONS MILLS VILLAGE CENTER IMPROVEMENTS

SHEET NO.	TOTAL SHEETS
36	109

PROFILE SHEET 6 OF 8
MAIN STREET

REV #	DATE
1	11/28/18

MAIN ST

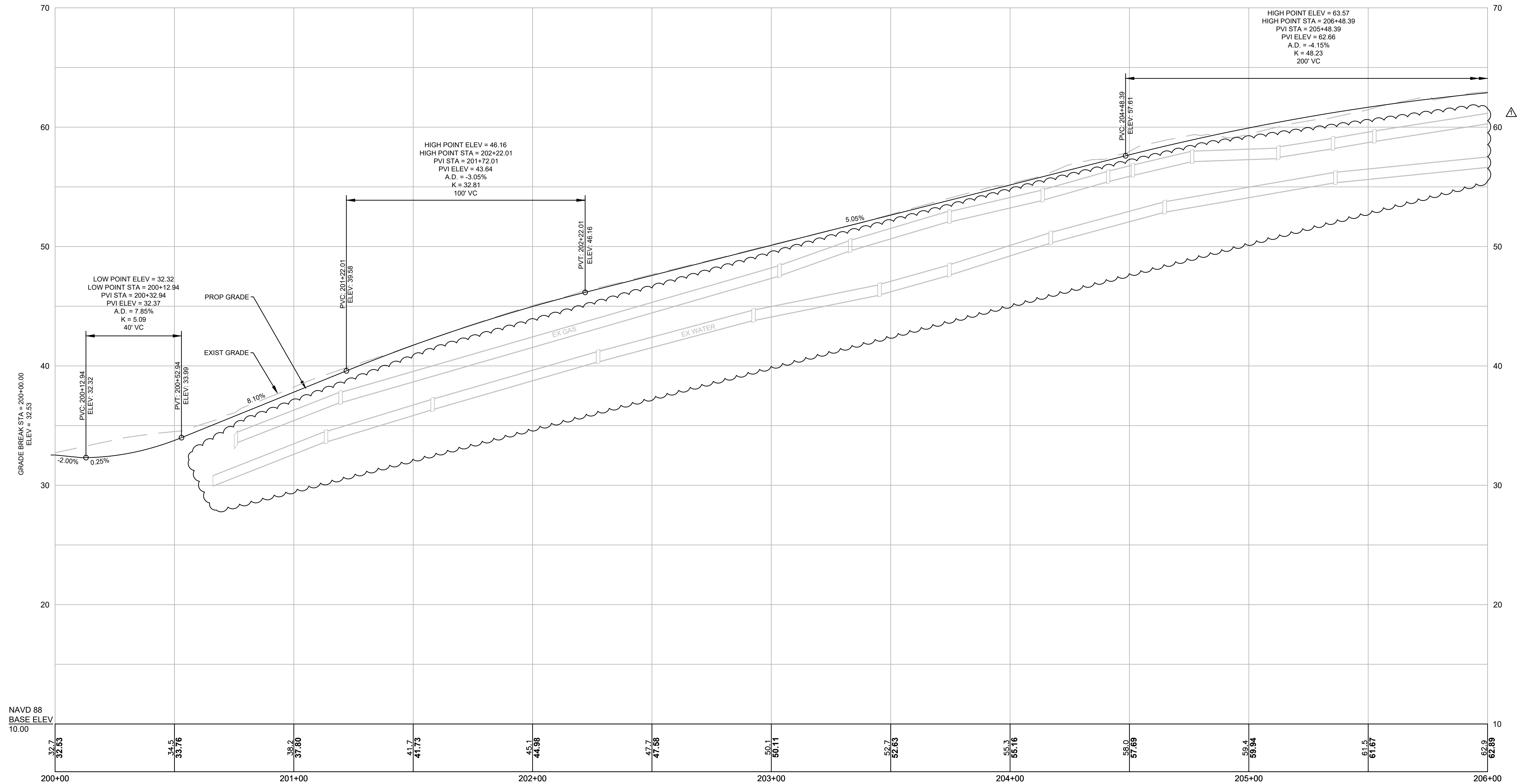

NAVD 88
BASE ELEV
10.00

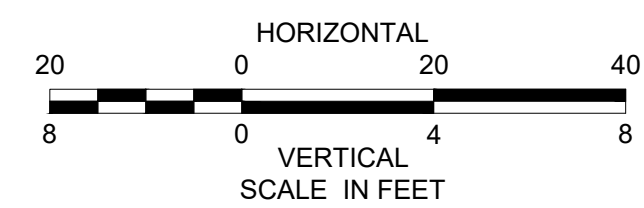

**BARNSTABLE
MARSTONS MILLS VILLAGE CENTER IMPROVEMENTS**

SHEET NO.	TOTAL SHEETS
37	109

**PROFILE SHEET 7 OF 8
MAIN STREET**

REV #	DATE
△	11/28/18

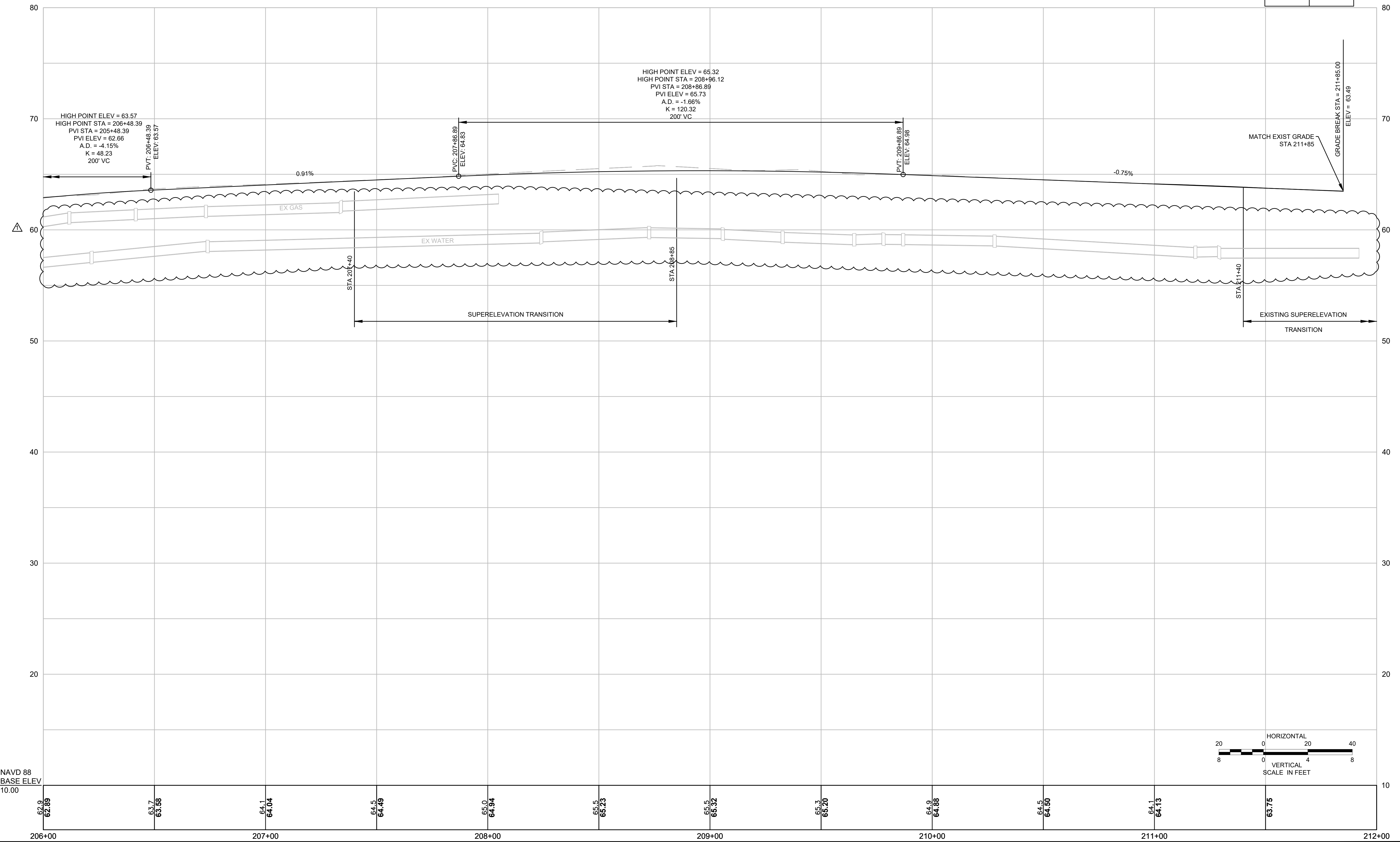

**BARNSTABLE
MARSTONS MILLS VILLAGE CENTER IMPROVEMENTS**

SHEET NO.	TOTAL SHEETS
38	109

**PROFILE SHEET 8 OF 8
RIVER ROAD**

REV #	DATE
△	11/28/18

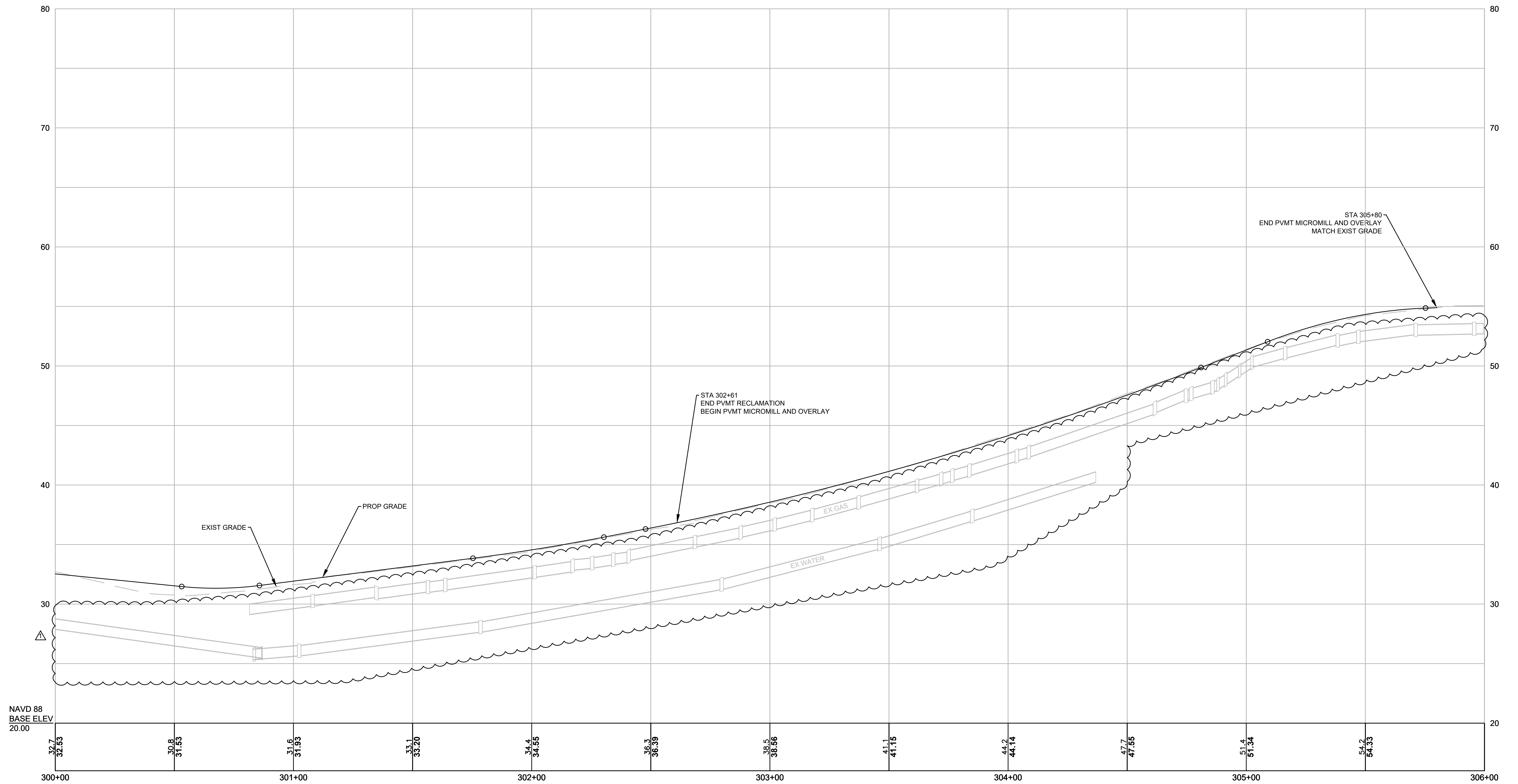

NAVD 88
BASE ELEV
20.00

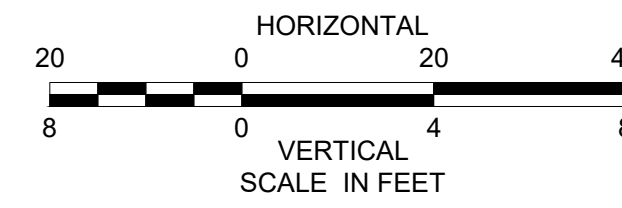

BARNSTABLE
MARSTONS MILLS VILLAGE CENTER IMPROVEMENTS

SHEET NO.	TOTAL SHEETS
39	109

CURB TIE PLAN
SHEET 1 OF 8

REV #	DATE
1	11/28/18

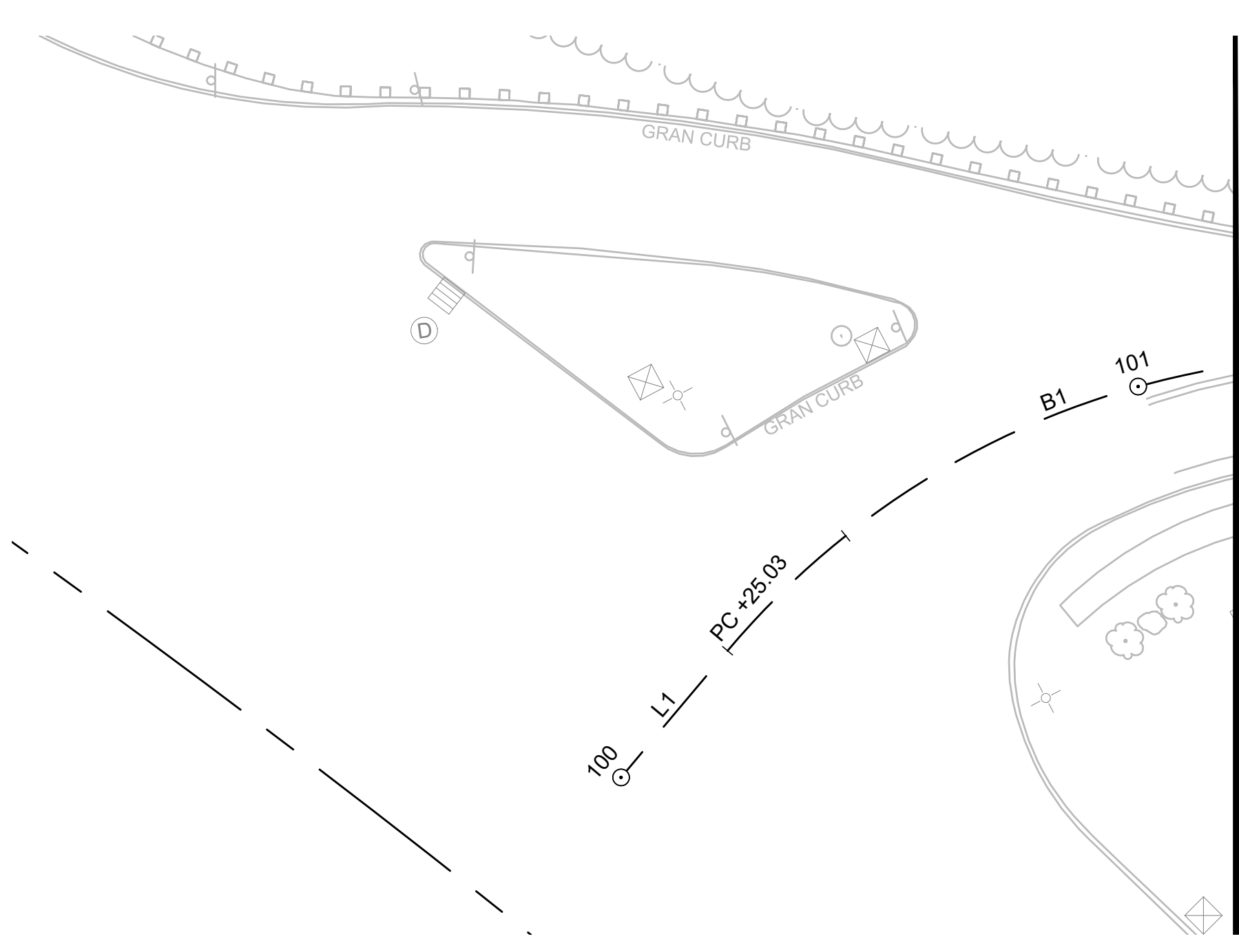
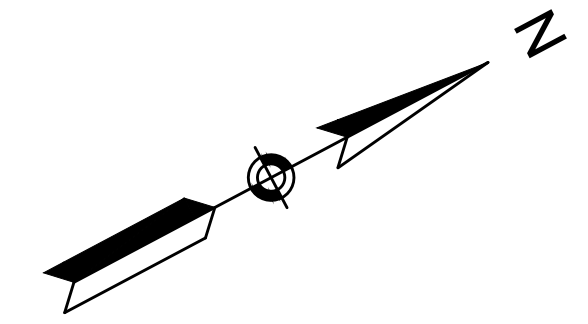

CONTINUED BELOW

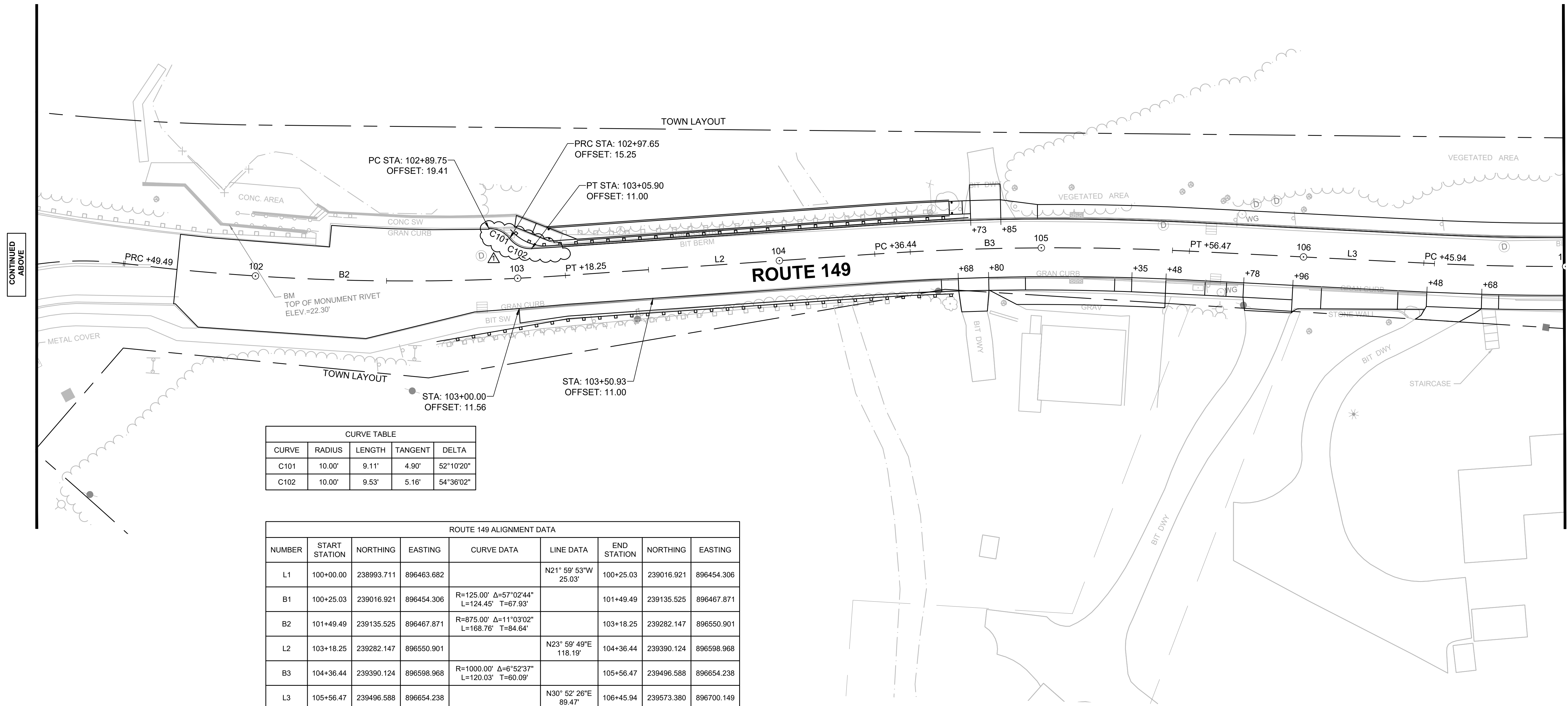

CONTINUED ABOVE

CONTINUED ON SHEET NO. 40

CURVE	RADIUS	LENGTH	TANGENT	DELTA
C101	10.00'	9.11'	4.90'	52°10'20"
C102	10.00'	9.53'	5.16'	54°36'02"

NUMBER	START STATION	NORTHING	EASTING	CURVE DATA	LINE DATA	END STATION	NORTHING	EASTING
L1	100+00.00	238993.711	896463.682		N21° 59' 53"W 25.03'	100+25.03	239016.921	896454.306
B1	100+25.03	239016.921	896454.306	R=125.00' Δ=57°02'44" L=124.45' T=67.93'		101+49.49	239135.525	896467.871
B2	101+49.49	239135.525	896467.871	R=875.00' Δ=11°03'02" L=168.76' T=84.64'		103+18.25	239282.147	896550.901
L2	103+18.25	239282.147	896550.901		N23° 59' 49"E 118.19'	104+36.44	239390.124	896598.968
B3	104+36.44	239390.124	896598.968	R=1000.00' Δ=6°52'37" L=120.03' T=60.09'		105+56.47	239496.588	896654.238
L3	105+56.47	239496.588	896654.238		N30° 52' 26"E 89.47'	106+45.94	239573.380	896700.149
B4	106+45.94	239573.380	896700.149	R=1000.00' Δ=13°16'48" L=231.78' T=116.41'		108+77.72	239784.262	896795.074

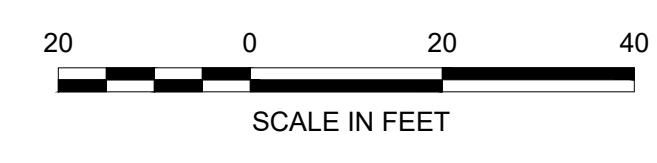

BARNSTABLE
MARSTONS MILLS VILLAGE CENTER IMPROVEMENTS

SHEET NO.	TOTAL SHEETS
40	109

CURB TIE PLAN
SHEET 2 OF 8

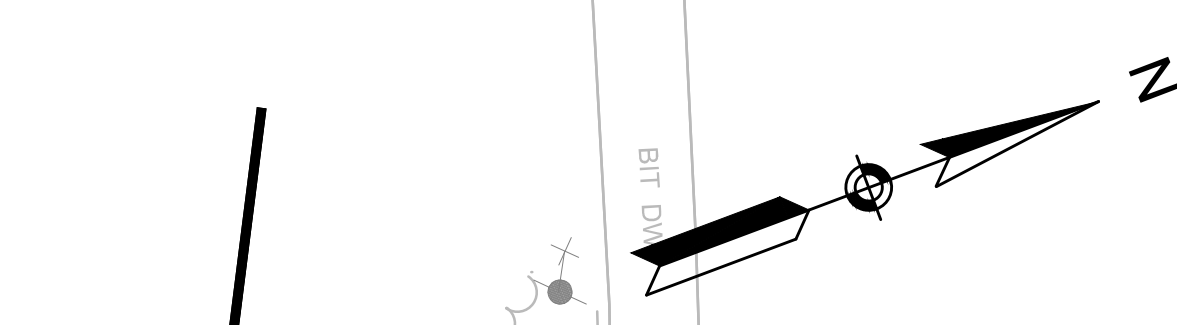
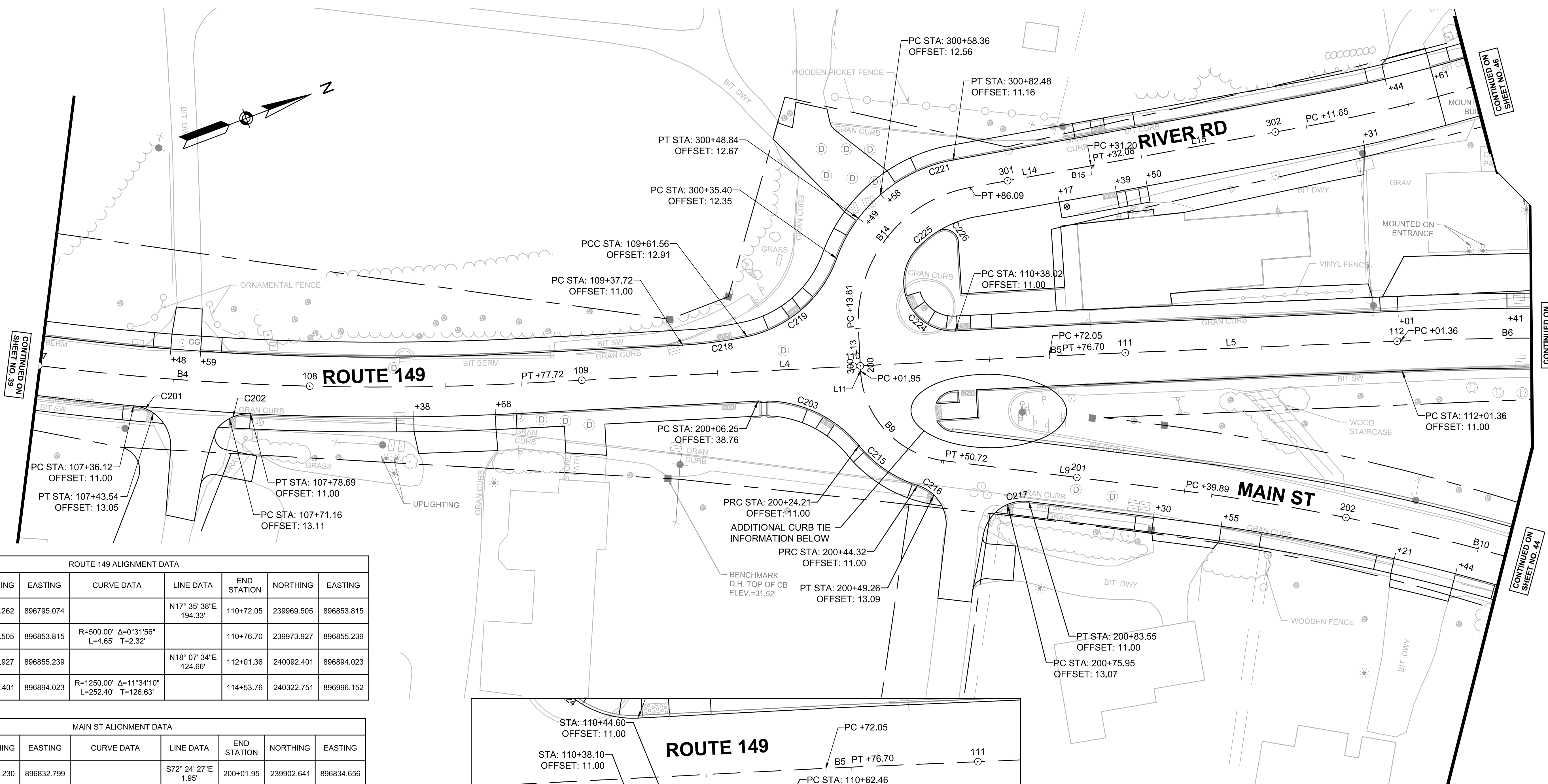

ROUTE 149 ALIGNMENT DATA								
NUMBER	START STATION	NORTHING	EASTING	CURVE DATA	LINE DATA	END STATION	NORTHING	EASTING
L4	108+77.72	239784.262	896795.074		N17° 35' 38"E 194.33'	110+72.05	239969.505	896853.815
B5	110+72.05	239969.505	896853.815	R=500.00' Δ=0°31'56" L=4.65' T=2.32'		110+76.70	239973.927	896855.239
L5	110+76.70	239973.927	896855.239		N18° 07' 34"E 124.66'	112+01.36	240092.401	896894.023
B6	112+01.36	240092.401	896894.023	R=1250.00' Δ=11°34'10" L=252.40' T=126.63'		114+53.76	240322.751	896996.152

MAIN ST ALIGNMENT DATA								
NUMBER	START STATION	NORTHING	EASTING	CURVE DATA	LINE DATA	END STATION	NORTHING	EASTING
L11	200+00.00	239903.230	896832.799		S72° 24' 27"E 1.95'	200+01.95	239902.641	896834.656
B9	200+01.95	239902.641	896834.656	R=35.00' Δ=79°50'33" L=48.77' T=29.29'		200+50.72	239919.708	896876.209
L9	200+50.72	239919.708	896876.209		N27° 45' 00"E 89.17'	201+39.89	239998.620	896917.726
B10	201+39.89	239998.620	896917.726	R=800.00' Δ=15°51'35" L=221.44' T=111.43'		203+61.33	240177.921	897046.471

RIVER RD - NEW ALIGNMENT DATA								
NUMBER	START STATION	NORTHING	EASTING	CURVE DATA	LINE DATA	END STATION	NORTHING	EASTING
L13	300+00.00	239903.230	896832.799		N72° 24' 22"W 13.81'	300+13.81	239907.403	896819.638
B14	300+13.81	239907.403	896819.638	R=50.00' Δ=82°49'40" L=72.28' T=44.10'		300+86.09	239964.108	896785.575
L14	300+86.09	239964.108	896785.575		N10° 25' 13"E 45.11'	301+31.20	240008.473	896793.733
B15	301+31.20	240008.473	896793.733	R=200.00' Δ=0°15'13" L=0.88' T=0.44'		301+32.08	240009.344	896793.892
L15	301+32.08	240009.344	896793.892		N10° 10' 00"E 79.57'	302+11.65	240087.666	896807.937
B16	302+11.65	240087.666	896807.937	R=600.00' Δ=14°54'42" L=156.15' T=78.52'		303+67.81	240243.204	896815.302

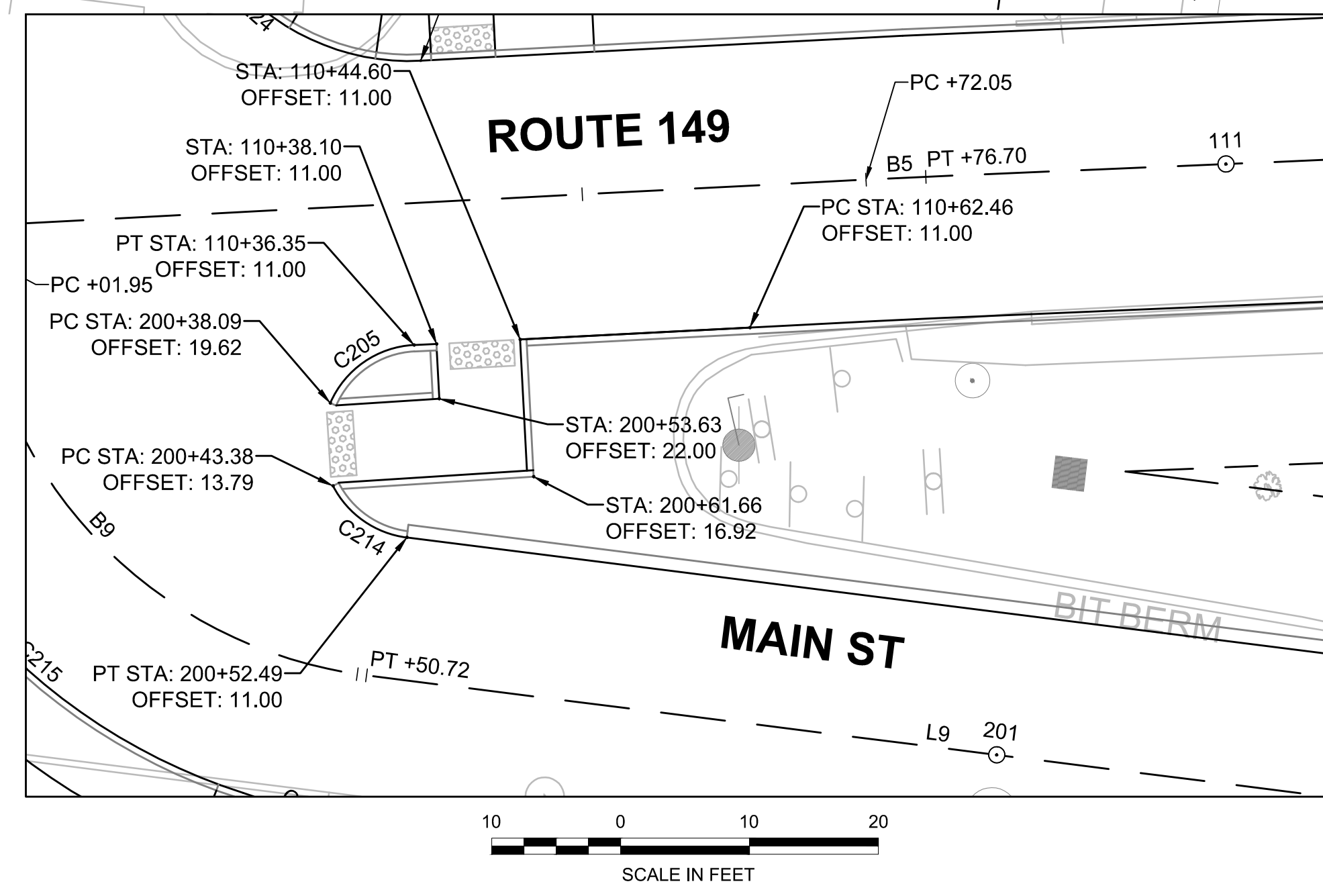

CURVE TABLE				
CURVE	RADIUS	LENGTH	TANGENT	DELTA
C201	15.00'	7.87'	4.03'	30°04'36"
C202	15.00'	8.00'	4.10'	30°34'08"
C203	45.00'	35.92'	18.98'	45°43'58"
C205	8.00'	8.32'	4.64'	63°32'05"
C214	8.00'	7.27'	3.95'	55°32'44"
C216	15.00'	7.02'	3.57'	26°47'56"
C217	15.00'	7.97'	4.08'	30°27'01"
C218	150.00'	23.94'	11.99'	9°08'34"
C219	45.00'	45.61'	24.98'	58°04'18"
C221	56.00'	23.00'	11.66'	23°31'38"
C224	18.00'	41.64'	43.69'	136°20'19"
C225	39.00'	9.74'	4.89'	14°18'12"
C226	5.00'	10.37'	8.45'	118°48'10"

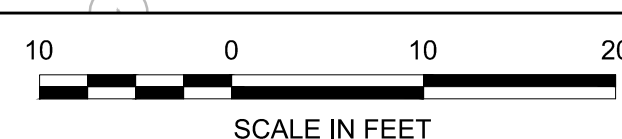

CONTINUED ON SHEET NO. 39

CONTINUED ON SHEET NO. 46

CONTINUED ON SHEET NO. 41

CONTINUED ON SHEET NO. 44

BARNSTABLE
MARSTONS MILLS VILLAGE CENTER IMPROVEMENTS

SHEET NO.	TOTAL SHEETS
41	109

CURB TIE PLAN
SHEET 3 OF 8

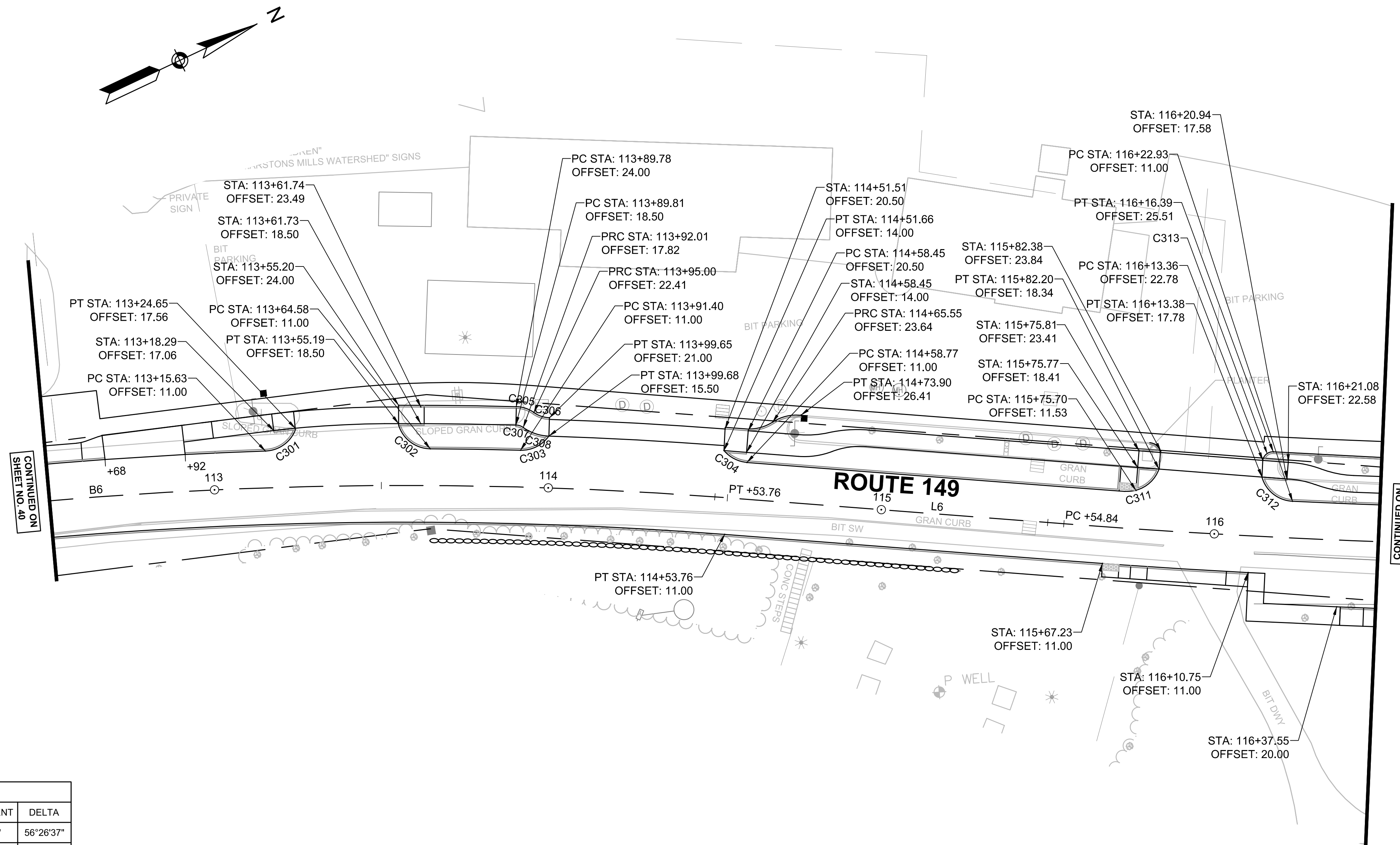

CONTINUED ON SHEET NO. 40

CONTINUED ON SHEET NO. 42

CURVE TABLE				
CURVE	RADIUS	LENGTH	TANGENT	DELTA
C303	10.00'	9.85'	5.37'	56°26'37"
C304	10.00'	7.95'	4.20'	45°32'22"
C305	10.00'	5.63'	2.90'	33°48'38"
C306	9.00'	5.01'	2.58'	33°37'06"
C307	4.00'	2.37'	1.22'	33°37'06"
C308	14.00'	8.24'	4.24'	33°37'06"
C311	10.00'	3.27'	1.65'	18°44'37"
C312	10.00'	12.45'	7.17'	71°18'35"
C313	3.00'	4.45'	2.75'	85°00'17"

ROUTE 149 ALIGNMENT DATA								
NUMBER	START STATION	NORTHING	EASTING	CURVE DATA	LINE DATA	END STATION	NORTHING	EASTING
L6	114+53.76	240322.751	896996.152		N29° 41' 44"E 101.07'	115+54.84	240410.551	897046.224

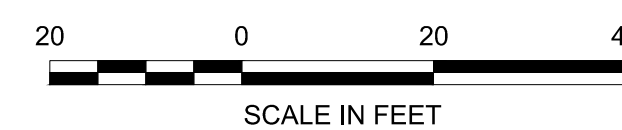

SHEET NO.	TOTAL SHEETS
42	109

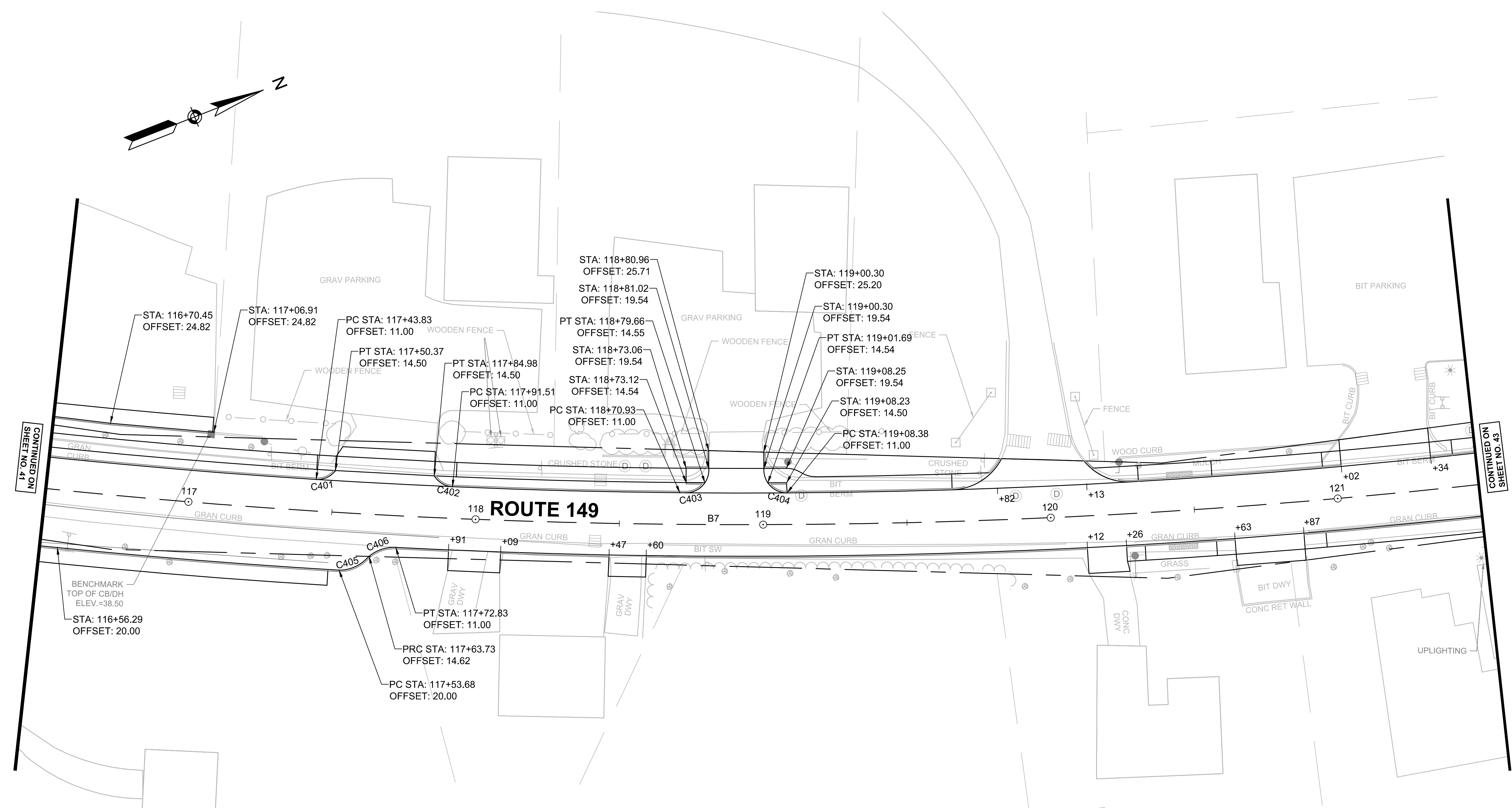

CONTINUED ON
SHEET NO. 41

CONTINUED ON
SHEET NO. 43

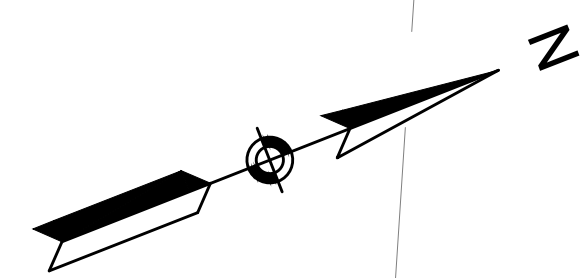

CURVE TABLE				
CURVE	RADIUS	LENGTH	TANGENT	DELTA
C401	8.00'	7.70'	4.20'	56°31'28"
C402	7.00'	6.87'	3.71'	53°52'58"
C403	8.00'	7.86'	4.28'	56°16'37"
C404	8.00'	7.85'	4.27'	56°12'16"
C405	13.00'	10.61'	5.60'	45°50'58"

ROUTE 149 ALIGNMENT DATA								
NUMBER	START STATION	NORTHING	EASTING	CURVE DATA	LINE DATA	END STATION	NORTHING	EASTING
B7	115+54.84	240410.551	897046.224	R=2350.00' Δ=15°59'25" L=655.85' T=330.07'		122+10.68	241017.944	897287.939

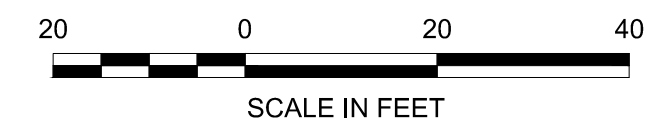

SHEET NO.	TOTAL SHEETS
43	109

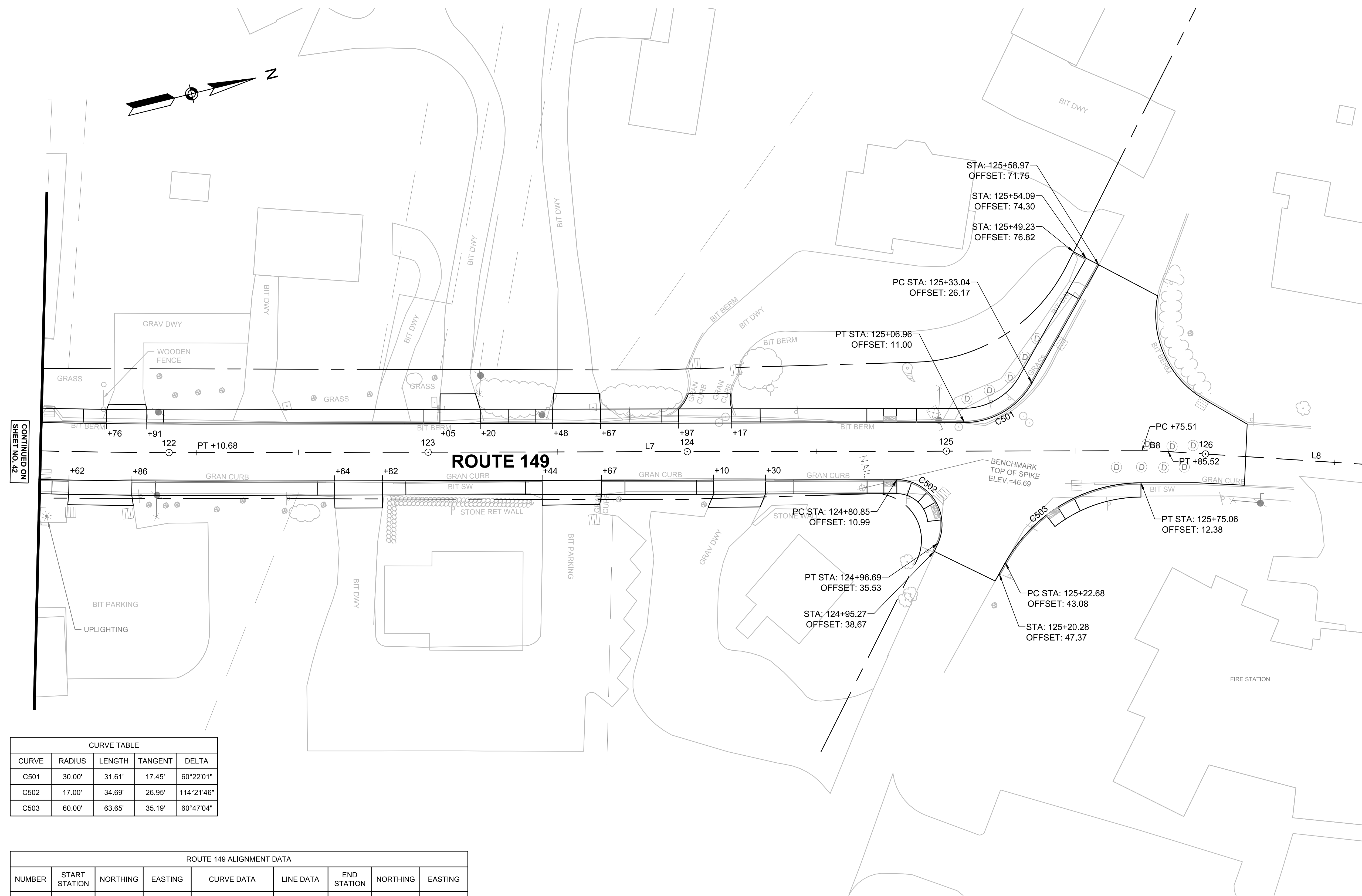

CONTINUED ON
SHEET NO. 42

CURVE TABLE				
CURVE	RADIUS	LENGTH	TANGENT	DELTA
C501	30.00'	31.61'	17.45'	60°22'01"
C502	17.00'	34.69'	26.95'	114°21'46"
C503	60.00'	63.65'	35.19'	60°47'04"

ROUTE 149 ALIGNMENT DATA								
NUMBER	START STATION	NORTHING	EASTING	CURVE DATA	LINE DATA	END STATION	NORTHING	EASTING
L7	122+10.68	241017.944	897287.939		N13° 42' 19"E 364.82'	125+75.51	241372.379	897374.376
B8	125+75.51	241372.379	897374.376	R=150.00' Δ=3°49'30" L=10.01' T=5.01'		125+85.52	241382.022	897377.071
L8	125+85.52	241382.022	897377.071		N17° 31' 49"E 114.48'	127+00.00	241491.185	897411.554

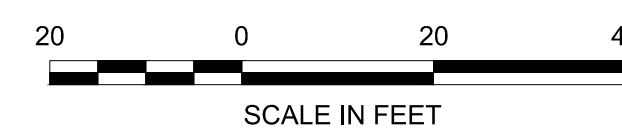

BARNSTABLE
MARSTONS MILLS VILLAGE CENTER IMPROVEMENTS

SHEET NO.	TOTAL SHEETS
44	109

CURB TIE PLAN
SHEET 6 OF 8

REV #	DATE
1	3/13/19

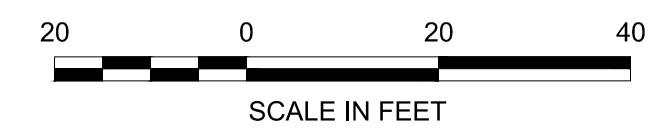
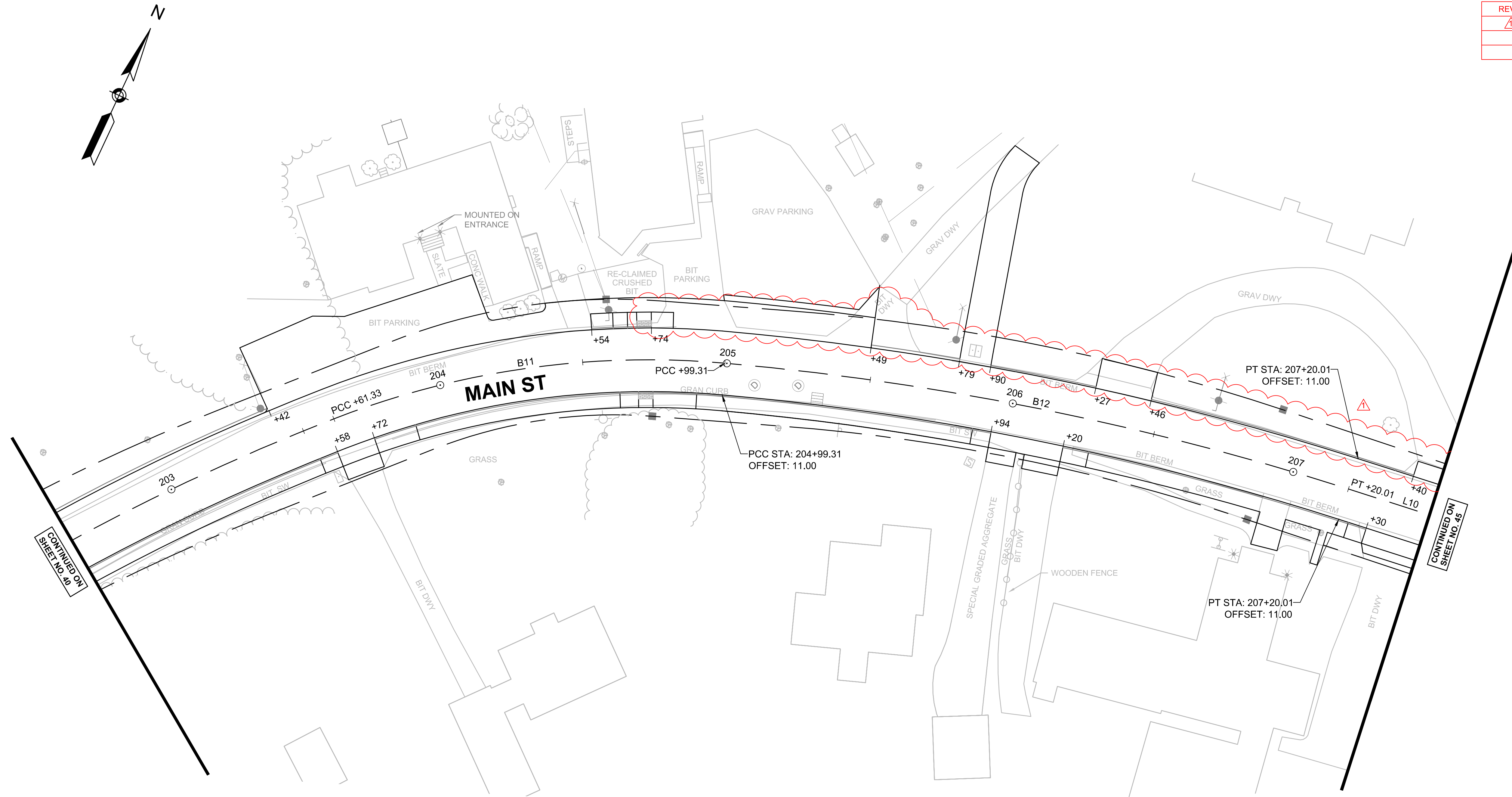

MAIN ST ALIGNMENT DATA								
NUMBER	START STATION	NORTHING	EASTING	CURVE DATA	LINE DATA	END STATION	NORTHING	EASTING
B11	203+61.33	240177.921	897046.471	R=300.00' Δ=26°21'07" L=137.98' T=70.23'		204+99.31	240252.837	897160.892
B12	204+99.31	240252.837	897160.892	R=1000.00' Δ=12°38'44" L=220.71' T=110.80'		207+20.01	240305.062	897374.870
L10	207+20.01	240305.062	897374.870		N82° 36' 25"E 133.10'	208+53.11	240322.189	897506.864

CONTINUED ON
SHEET NO. 46

CONTINUED ON
SHEET NO. 45

BARNSTABLE
MARSTONS MILLS VILLAGE CENTER IMPROVEMENTS

SHEET NO.	TOTAL SHEETS
45	109

CURB TIE PLAN
SHEET 7 OF 8

REV #	DATE
1	3/13/19

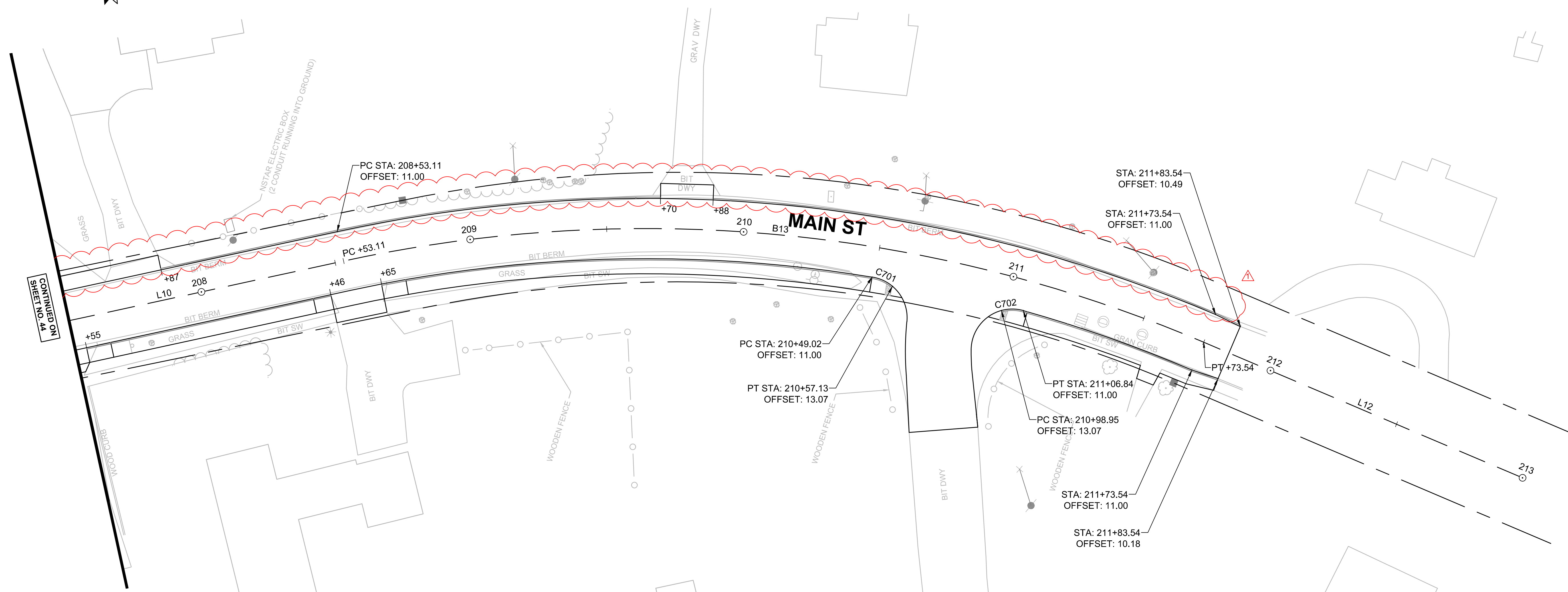
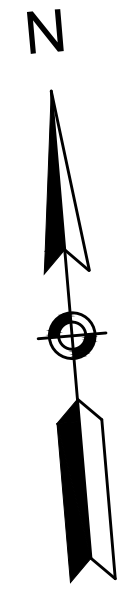

CONTINUED ON
SHEET NO. 44

CURVE	RADIUS	LENGTH	TANGENT	DELTA
C701	15.00'	8.08'	4.14'	30°52'26"
C702	15.00'	8.08'	4.14'	30°52'26"

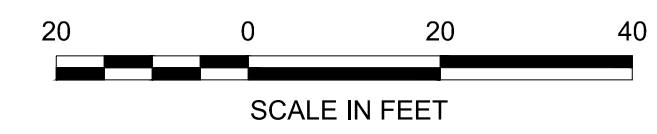

NUMBER	START STATION	NORTHING	EASTING	CURVE DATA	LINE DATA	END STATION	NORTHING	EASTING
B13	208+53.11	240322.189	897506.864	R=520.00' Δ=35°18'22" L=320.43' T=165.48'		211+73.54	240266.015	897817.204
L12	211+73.54	240266.015	897817.204		S62° 05' 13"E 126.45'	213+00.00	240206.818	897928.945

SHEET NO.	TOTAL SHEETS
46	109

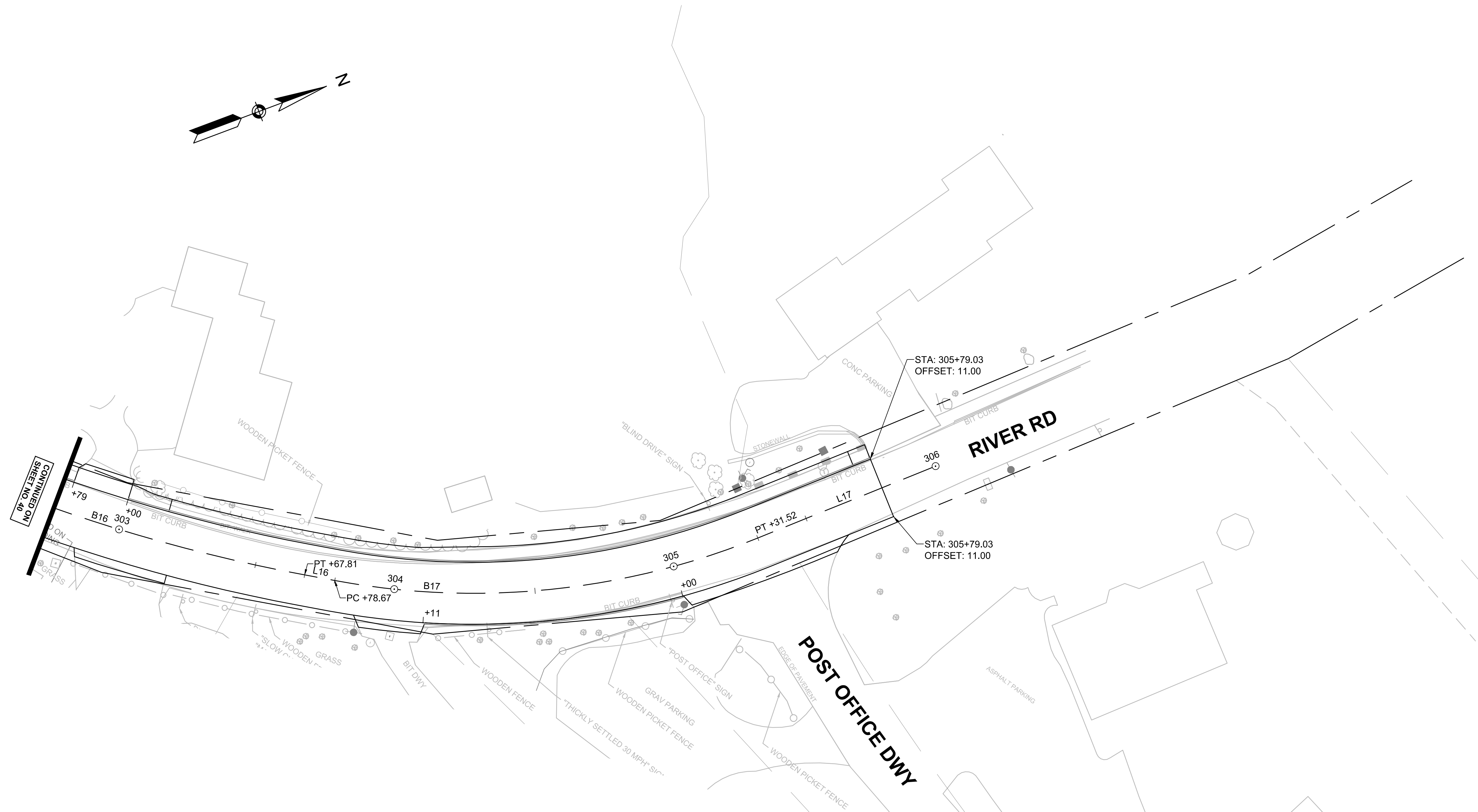

RIVER RD - NEW ALIGNMENT DATA								
NUMBER	START STATION	NORTHING	EASTING	CURVE DATA	LINE DATA	END STATION	NORTHING	EASTING
B16	302+11.65	240087.666	896807.937	R=600.00' Δ=14°54'42" L=156.15' T=78.52'		303+67.81	240243.204	896815.302
L16	303+67.81	240243.204	896815.302		N4° 44' 41"W 10.87'	303+78.67	240254.036	896814.403
B17	303+78.67	240254.036	896814.403	R=269.00' Δ=32°33'17" L=152.84' T=78.55'		305+31.52	240394.794	896760.309
L17	305+31.52	240394.794	896760.309		N37° 17' 58"W 68.02'	305+99.54	240448.903	896719.090

BARNSTABLE
MARSTONS MILLS VILLAGE CENTER IMPROVEMENTS

SHEET NO.	TOTAL SHEETS
47	109

GRADING PLAN
SHEET 1 OF 1

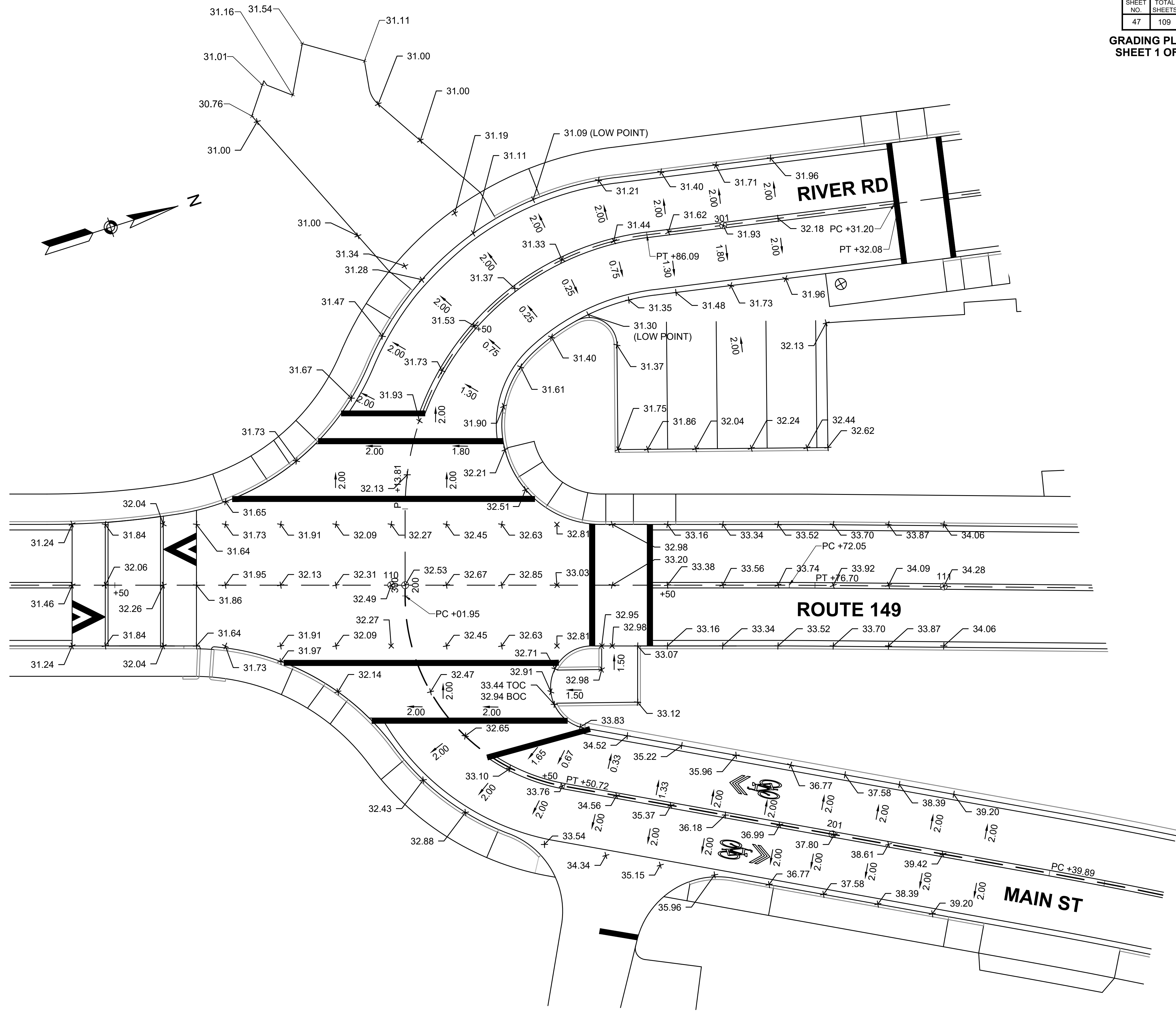

SCALE IN FEET

BARNSTABLE
MARSTONS MILLS VILLAGE CENTER IMPROVEMENTS

SHEET NO.	TOTAL SHEETS
48	108

LANDSCAPE PLANS (1)
SHEET 1 OF 8

REV #	DATE
1	11/28/18

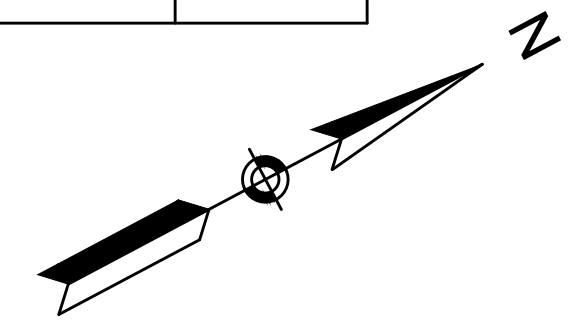

Node 1 Plant List

Key	Qty	Botanical Name	Common Name	Size	Spacing
Trees					
AAB	5	<i>Amelanchier X grandiflora</i> 'Autumn Brilliance'	Autumn Brilliance Serviceberry	7'-8' B&B	As Shown
Ground Cover/Grasses/Perennials					
AH	30	<i>Amsonia hubrichtii</i>	Thread-leaf Bluestar	#1	30" O.C.
CP	70	<i>Carex pennsylvanica</i>	Pennsylvania Sedge	plugs	18" O.C.
ES	40	<i>Eragrostis spectabilis</i>	Purple Lovegrass	#1	30" O.C.
GR	50	<i>Geranium 'Rozanne'</i>	Rozanne Cranesbill	#1	18" O.C.
NB	60	<i>Narcissus 'Dutch Master'</i>	Daffodil Blubs	bulbs	12" O.C.
OF	30	<i>Oenothera fruticosa</i>	Narrow-leaved Sundrops	#1	30" O.C.

Pond Bank Restoration Plant List

Key	Qty	Botanical Name	Common Name	Size	Spacing
Shrubs					
CA	7	<i>Clethra alnifolia</i>	White Summer Sweet	#7	4' O.C.
VC	6	<i>Vaccinium corymbosum</i>	Highbush Blueberry	3'-4' h.	6' O.C.
Ground Cover/Grasses/Perennials					
CL	85	<i>Carex lurida</i>	Shallow Sedge	plugs	12" O.C.
CSC	85	<i>Carex scoparia</i>	Broom Sedge	plugs	12" O.C.
CV	85	<i>Carex vulpinoidea</i>	Fox Sedge	plugs	12" O.C.
JE	85	<i>Juncus effusus</i>	Soft Rush	plugs	12" O.C.
OSE	85	<i>Onoclea sensibilis</i>	Sensitive Fern	#1	18" O.C.
OC	85	<i>Osmunda cinnamomea</i>	Cinnamon Fern	#1	18" O.C.

Landscape Plan 1 Plant List

Key	Qty	Botanical Name	Common Name	Size	Spacing
Trees					
LST	2	<i>Liquidambar styraciflua</i>	Sweet Gum	2.5"-3" cal.	As Shown
UA	2	<i>Ulmus americana</i> 'Valley Forge'	Valley Forge American Elm	2.5"-3" cal.	As Shown

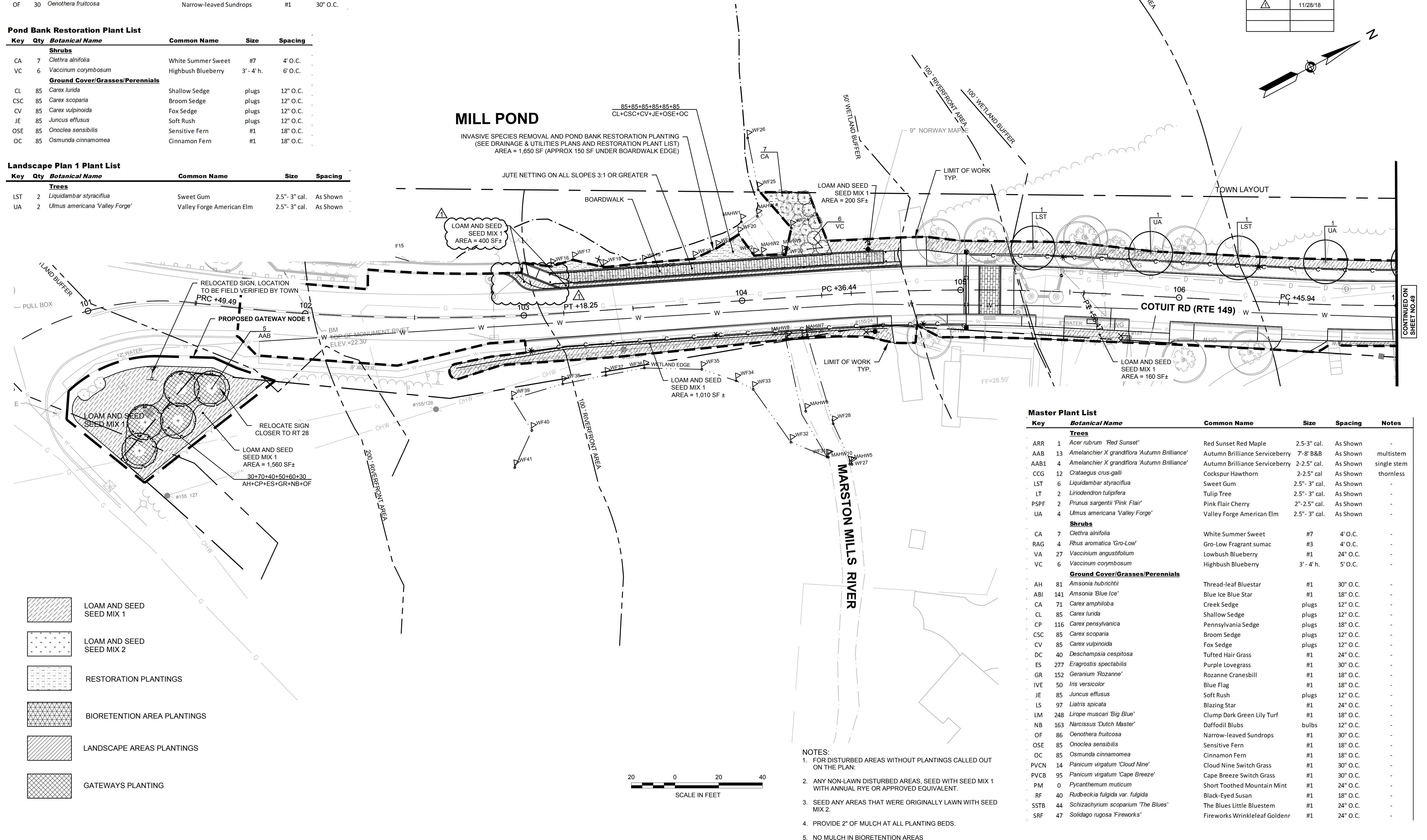

Master Plant List

Key	Botanical Name	Common Name	Size	Spacing	Notes
Trees					
ARR	<i>Acer rubrum</i> 'Red Sunset'	Red Sunset Red Maple	2.5-3" cal.	As Shown	-
AAB	<i>Amelanchier X grandiflora</i> 'Autumn Brilliance'	Autumn Brilliance Serviceberry	7'-8' B&B	As Shown	multistem
AAB1	<i>Amelanchier X grandiflora</i> 'Autumn Brilliance'	Autumn Brilliance Serviceberry	2-2.5" cal.	As Shown	single stem
CCG	<i>Crataegus crus-galli</i>	Cockspur Hawthorn	2-2.5" cal.	As Shown	thornless
LST	<i>Liquidambar styraciflua</i>	Sweet Gum	2.5"-3" cal.	As Shown	-
LT	<i>Liriodendron tulipifera</i>	Tulip Tree	2.5"-3" cal.	As Shown	-
PSPF	<i>Prunus sargentii</i> 'Pink Flair'	Pink Flair Cherry	2"-2.5" cal.	As Shown	-
UA	<i>Ulmus americana</i> 'Valley Forge'	Valley Forge American Elm	2.5"-3" cal.	As Shown	-
Shrubs					
CA	<i>Clethra alnifolia</i>	White Summer Sweet	#7	4' O.C.	-
RAG	<i>Rhus aromatica</i> 'Gro-Low'	Gro-Low Fragrant sumac	#3	4' O.C.	-
VA	<i>Vaccinium angustifolium</i>	Lowbush Blueberry	#1	24" O.C.	-
VC	<i>Vaccinium corymbosum</i>	Highbush Blueberry	3'-4' h.	5' O.C.	-
Ground Cover/Grasses/Perennials					
AH	<i>Amsonia hubrichtii</i>	Thread-leaf Bluestar	#1	30" O.C.	-
ABI	<i>Amsonia 'Blue Ice'</i>	Blue Ice Blue Star	#1	18" O.C.	-
CA	<i>Carex amphibia</i>	Creek Sedge	plugs	12" O.C.	-
CL	<i>Carex lurida</i>	Shallow Sedge	plugs	12" O.C.	-
CP	<i>Carex pennsylvanica</i>	Pennsylvania Sedge	plugs	18" O.C.	-
CSC	<i>Carex scoparia</i>	Broom Sedge	plugs	12" O.C.	-
CV	<i>Carex vulpinoidea</i>	Fox Sedge	plugs	12" O.C.	-
DC	<i>Deschampsia cespitosa</i>	Tufted Hair Grass	#1	24" O.C.	-
ES	<i>Eragrostis spectabilis</i>	Purple Lovegrass	#1	30" O.C.	-
GR	<i>Geranium 'Rozanne'</i>	Rozanne Cranesbill	#1	18" O.C.	-
IVE	<i>Iris versicolor</i>	Blue Flag	#1	18" O.C.	-
JE	<i>Juncus effusus</i>	Soft Rush	plugs	12" O.C.	-
LS	<i>Liatris spicata</i>	Blazing Star	#1	24" O.C.	-
LM	<i>Liriope muscari</i> 'Big Blue'	Clump Dark Green Lily Turf	#1	18" O.C.	-
NB	<i>Narcissus 'Dutch Master'</i>	Daffodil Blubs	bulbs	12" O.C.	-
OF	<i>Oenothera fruticosa</i>	Narrow-leaved Sundrops	#1	30" O.C.	-
OSE	<i>Onoclea sensibilis</i>	Sensitive Fern	#1	18" O.C.	-
OC	<i>Osmunda cinnamomea</i>	Cinnamon Fern	#1	18" O.C.	-
PVCN	<i>Panicum virgatum</i> 'Cloud Nine'	Cloud Nine Switch Grass	#1	30" O.C.	-
PVCB	<i>Panicum virgatum</i> 'Cape Breeze'	Cape Breeze Switch Grass	#1	30" O.C.	-
PM	<i>Pycnanthemum muticum</i>	Short Toothed Mountain Mint	#1	24" O.C.	-
RF	<i>Rudbeckia fulgida</i> var. <i>fulgida</i>	Black-Eyed Susan	#1	18" O.C.	-
SSTB	<i>Schizachyium scoparium</i> 'The Blues'	The Blues Little Bluestem	#1	24" O.C.	-
SRF	<i>Solidago rugosa</i> 'Fireworks'	Fireworks Wrinkleleaf Goldenr	#1	24" O.C.	-

- NOTES:
- FOR DISTURBED AREAS WITHOUT PLANTINGS CALLED OUT ON THE PLAN;
 - ANY NON-LAWN DISTURBED AREAS, SEED WITH SEED MIX 1 WITH ANNUAL RYE OR APPROVED EQUIVALENT.
 - SEED ANY AREAS THAT WERE ORIGINALLY LAWN WITH SEED MIX 2.
 - PROVIDE 2" OF MULCH AT ALL PLANTING BEDS.
 - NO MULCH IN BIORETENTION AREAS

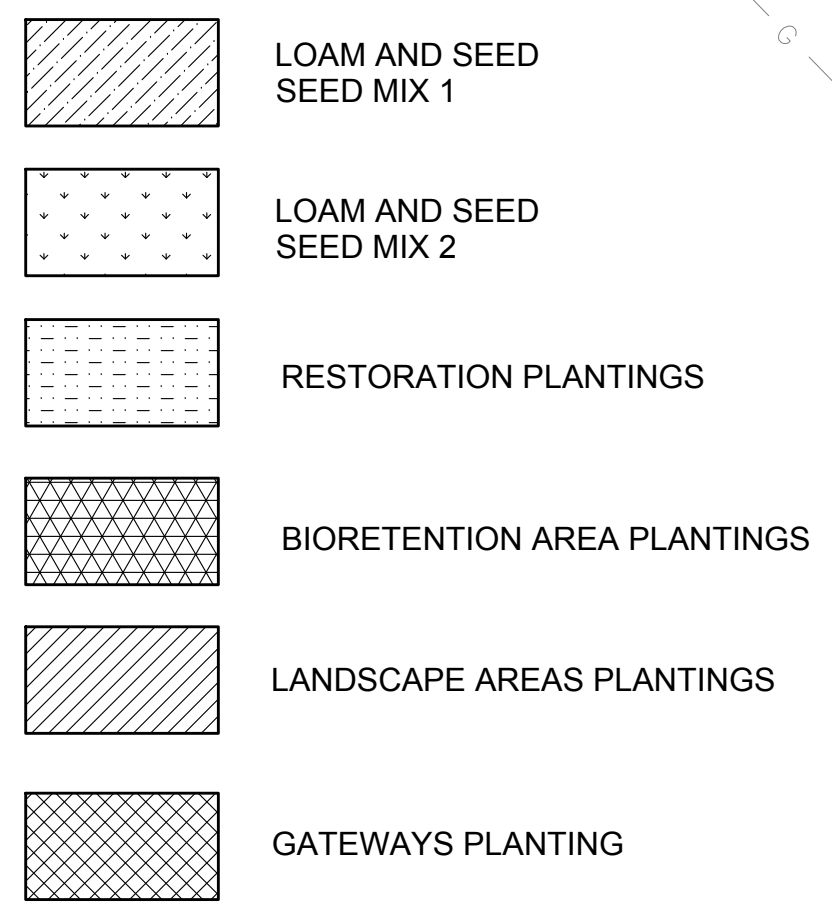
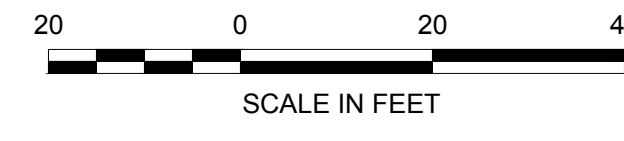

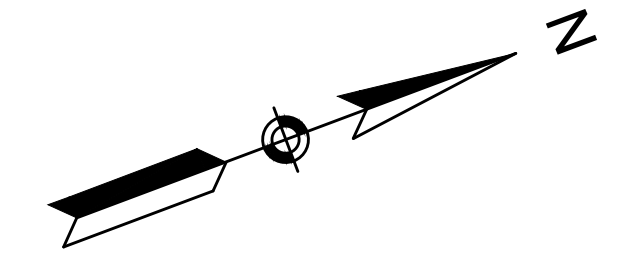

Gateway Node 2 Plant List

Key	Qty	Botanical Name	Common Name	Size	Spacing
Trees					
LST	1	<i>Liquidambar styraciflua</i>	Sweet Gum	2.5"-3" cal.	As Shown
Shrubs					
VA	27	<i>Vaccinium angustifolium</i>	Lowbush Blueberry	#1	24" O.C.
Ground Cover/Grasses/Perennials					
AH	8	<i>Amsonia hubrichtii</i>	Thread-leaf Bluestar	#1	30" O.C.
ABI	20	<i>Amsonia 'Blue Ice'</i>	Blue Ice Blue Star	#1	18" O.C.
EP	12	<i>Echinacea purpurea 'Ruby Star'</i>	Ruby Star Purple Coneflower	#1	18" O.C.
ES	41	<i>Eragrostis spectabilis</i>	Purple Lovegrass	#1	30" O.C.
GR	31	<i>Geranium 'Rozanne'</i>	Rozanne Cranesbill	#1	18" O.C.
LS	35	<i>Liatris spicata</i>	Blazing Star	#1	24" O.C.
OF	8	<i>Oenothera fruticosa</i>	Narrow-leaved Sundrops	#1	30" O.C.
PVCN	14	<i>Panicum virgatum 'Cloud Nine'</i>	Cloud Nine Switch Grass	#1	30" O.C.

Landscape Plan 2 Plant List

Key	Qty	Botanical Name	Common Name	Size	Spacing	Notes
Trees						
AAB	5	<i>Amelanchier X grandiflora 'Autumn Brilliance'</i>	Autumn Brilliance Serviceberry	7'-8" B&B	As Shown	multistem
AAB1	1	<i>Amelanchier X grandiflora 'Autumn Brilliance'</i>	Autumn Brilliance Serviceberry	2-2.5" cal.	As Shown	single stem
LST	3	<i>Liquidambar styraciflua</i>	Sweet Gum	2.5"-3" cal.	As Shown	
UA	4	<i>Ulmus americana 'Valley Forge'</i>	Valley Forge American Elm	2.5"-3" cal.	As Shown	
Shrubs						
RAG	4	<i>Rhus aromatica 'Gro-Low'</i>	Gro-Low Fragrant sumac	#3	As Shown	
Ground Cover/Grasses/Perennials						
AH	28	<i>Amsonia hubrichtii</i>	Thread-leaf Bluestar	#1	30" O.C.	
ABI	45	<i>Amsonia 'Blue Ice'</i>	Blue Ice Blue Star	#1	18" O.C.	
ES	84	<i>Eragrostis spectabilis</i>	Purple Lovegrass	#1	30" O.C.	
GR	66	<i>Geranium 'Rozanne'</i>	Rozanne Cranesbill	#1	18" O.C.	
NB	78	<i>Narcissus 'Dutch Master'</i>	Daffodil Blubs	bulbs	12" O.C.	
OF	33	<i>Oenothera fruticosa</i>	Narrow-leaved Sundrops	#1	30" O.C.	
PVCB	35	<i>Panicum virgatum 'Cape Breeze'</i>	Cape Breeze Switch Grass	#1	30" O.C.	
RF	35	<i>Rudbeckia fulgida var. fulgida</i>	Black-Eyed Susan	#1	18" O.C.	

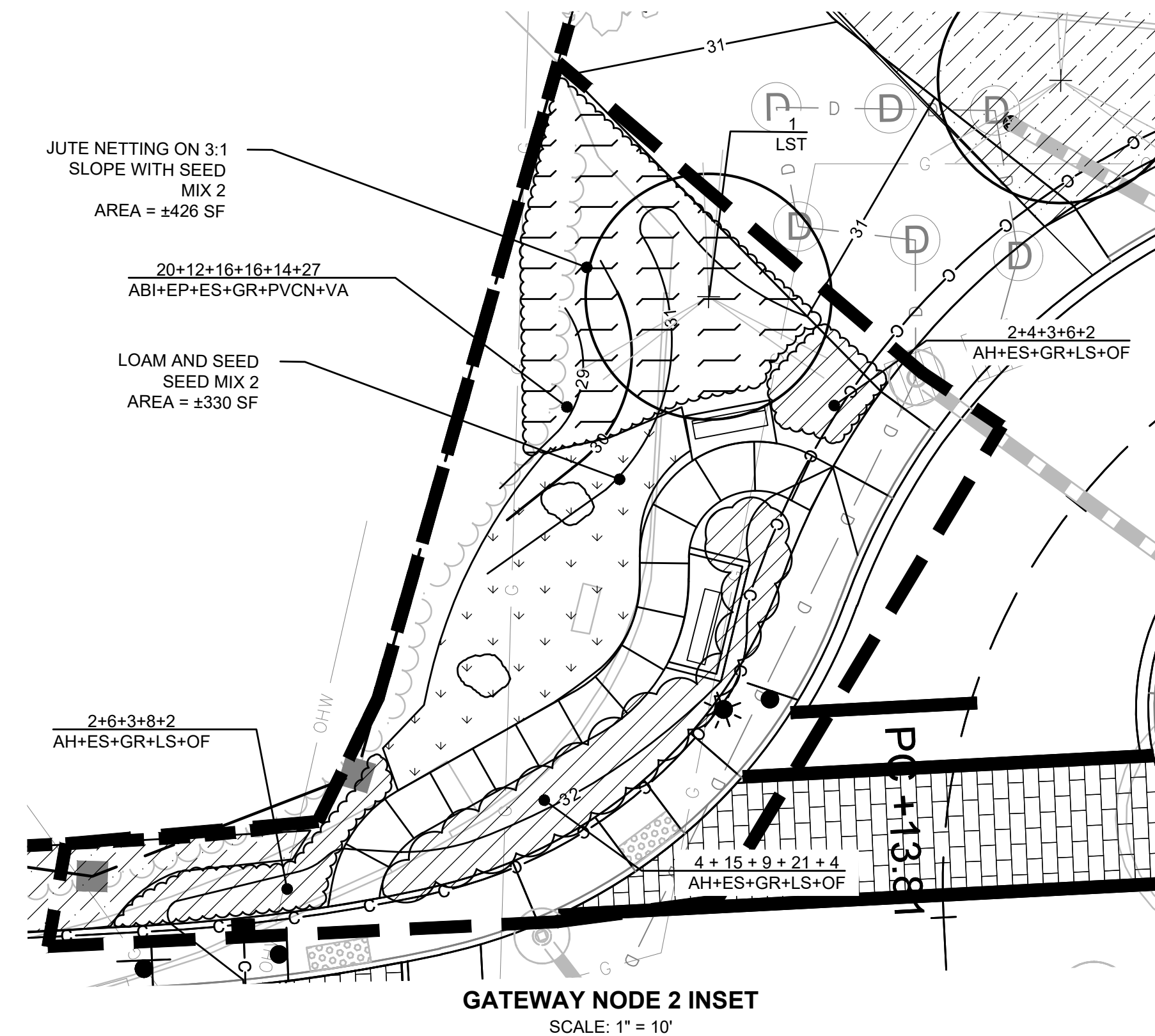

- LOAM AND SEED SEED MIX 1
- LOAM AND SEED SEED MIX 2
- RESTORATION PLANTINGS
- BIORETENTION AREA PLANTINGS
- LANDSCAPE AREAS PLANTINGS
- GATEWAYS PLANTING

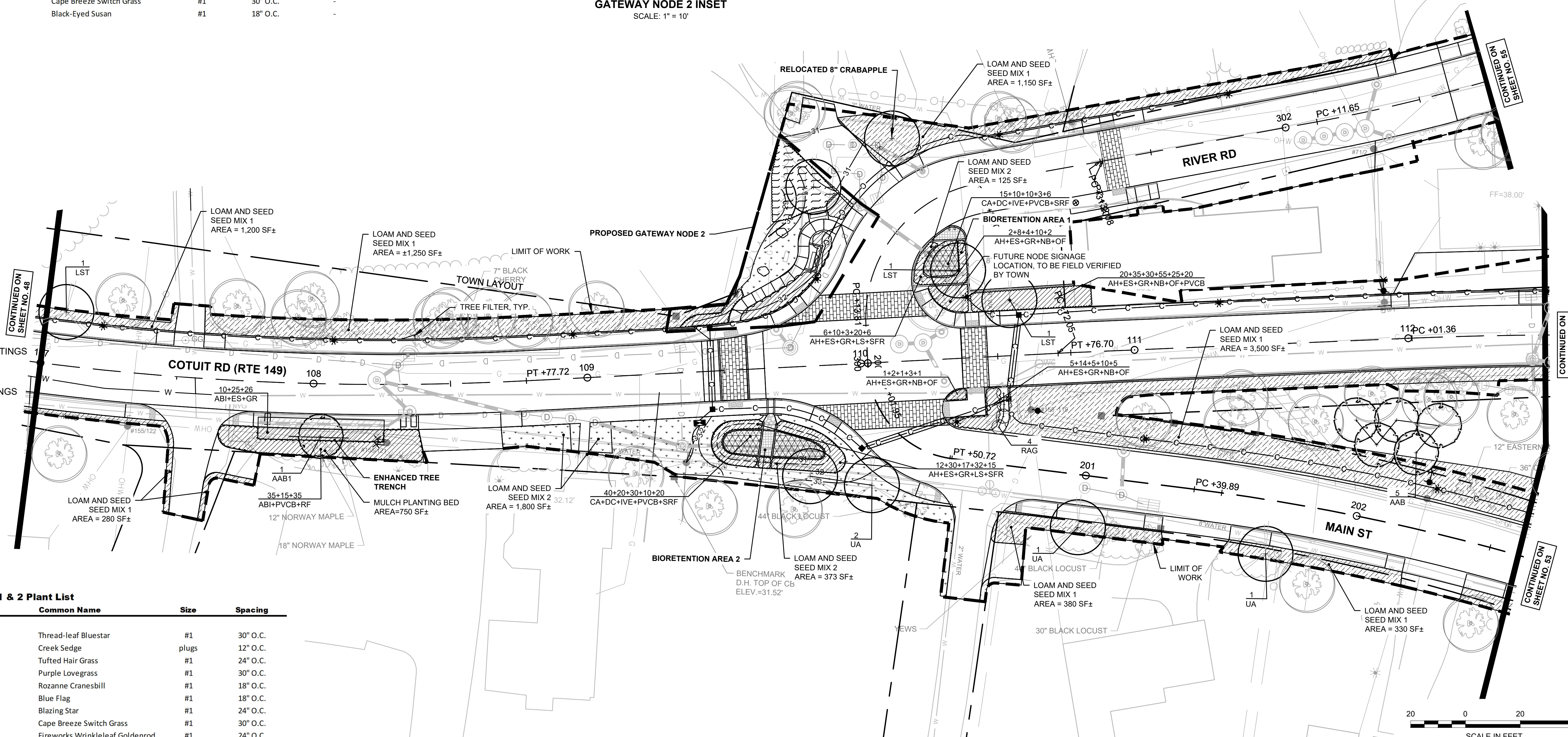

Landscape Plan 2 - Bioretention Areas 1 & 2 Plant List

Key	Qty	Botanical Name	Common Name	Size	Spacing
Ground Cover/Grasses/Perennials					
AH	18	<i>Amsonia hubrichtii</i>	Thread-leaf Bluestar	#1	30" O.C.
CA	55	<i>Carex amphibia</i>	Creek Sedge	plugs	12" O.C.
DC	30	<i>Deschampsia cespitosa</i>	Tufted Hair Grass	#1	24" O.C.
ES	40	<i>Eragrostis spectabilis</i>	Purple Lovegrass	#1	30" O.C.
GR	20	<i>Geranium 'Rozanne'</i>	Rozanne Cranesbill	#1	18" O.C.
IVE	40	<i>Iris versicolor</i>	Blue Flag	#1	18" O.C.
LS	52	<i>Liatris spicata</i>	Blazing Star	#1	24" O.C.
PVCB	13	<i>Panicum virgatum 'Cape Breeze'</i>	Cape Breeze Switch Grass	#1	30" O.C.
SRF	47	<i>Solidago rugosa 'Fireworks'</i>	Fireworks Wrinkleleaf Goldenrod	#1	24" O.C.

SHEET NO.	TOTAL SHEETS
50	108

Landscape Plan 3 Plant List

Key	Qty	Botanical Name	Common Name	Size	Spacing	Notes
Trees						
CCG	6	<i>Crataegus crus-galli</i>	Cockspur Hawthorn	2-2.5" cal	As Shown	Thornless
PSPF	2	<i>Prunus sargentii</i> 'Pink Flair'	Pink Flair Cherry	2-2.5" cal.	As Shown	-
Ground Cover/Grasses/Perennials						
ABI	45	<i>Amsonia</i> 'Blue Ice'	Blue Ice Blue Star	#1	18" O.C.	-
ES	50	<i>Eragrostis spectabilis</i>	Purple Lovegrass	#1	30" O.C.	-
GR	48	<i>Geranium</i> 'Rozanne'	Rozanne Cranesbill	#1	18" O.C.	-
LM	48	<i>Lirape muscari</i> 'Big Blue'	Clump Dark Green Lily Turf	Plugs	18" O.C.	-
RF	20	<i>Rudbeckia fulgida</i> var. <i>fulgida</i>	Black-Eyed Susan	#1	18" O.C.	-
SH	47	<i>Sporobolus heterolepis</i>	Prairie Dropseed	#1	30" O.C.	-

Landscape Plan 3 - Bioswale 1 List

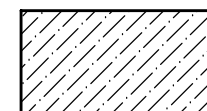
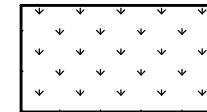
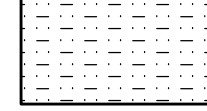
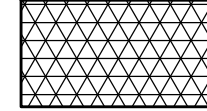
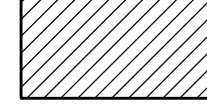
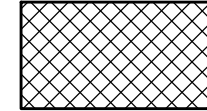

Key	Qty	Botanical Name	Common Name	Size	Spacing
Ground Cover/Grasses/Perennials					
CA	16	<i>Carex amphibia</i>	Creek Sedge	plugs	12" O.C.
CP	16	<i>Carex pensylvanica</i>	Pennsylvania Sedge	plugs	18" O.C.
DC	10	<i>Deschampsia cespitosa</i>	Tufted Hair Grass	#1	24" O.C.
IVE	12	<i>Iris versicolor</i>	Blue Flag	#1	18" O.C.
LS	10	<i>Liatis spicata</i>	Blazing Star	#1	24" O.C.

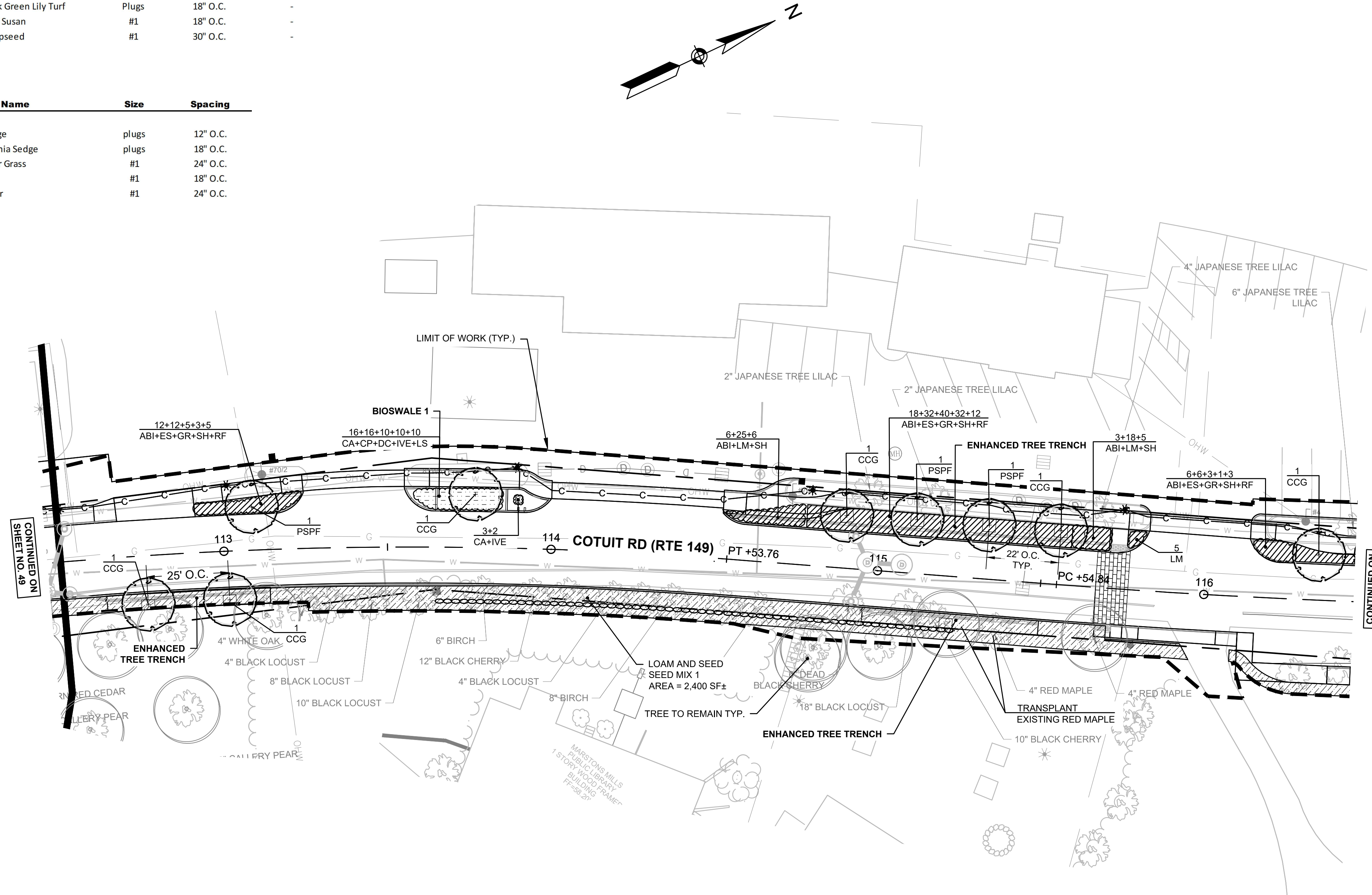
-  LOAM AND SEED SEED MIX 1
-  LOAM AND SEED SEED MIX 2
-  RESTORATION PLANTINGS
-  BIORETENTION AREA PLANTINGS
-  LANDSCAPE AREAS PLANTINGS
-  GATEWAYS PLANTING

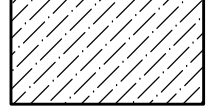
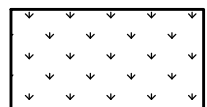
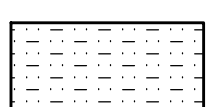
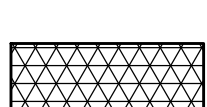

Landscape Plan 4 Plant List

Key	Qty	Botanical Name	Common Name	Size	Spacing	Notes
Trees						
AAB1	3	<i>Amelanchier X grandiflora</i> 'Autumn Brilliance'	Autumn Brilliance Serviceberry	2-2.5" cal.	As Shown	single stem
CCG	4	<i>Crataegus crus-galli</i>	Cockspur Hawthorn	2-2.5" cal	As Shown	Thornless
Ground Cover/Grasses/Perennials						
ABI	16	<i>Amsonia</i> 'Blue Ice'	Blue Ice Blue Star	#1	24" O.C.	-
LM	200	<i>Liriope muscari</i> 'Big Blue'	Clump Dark Green Lily Turf	Plugs	18" O.C.	-
SSTB	44	<i>Schizachyrium scoparium</i> 'The Blues'	The Blues Little Bluestem	#1	24" O.C.	-

-  LOAM AND SEED SEED MIX 1
-  LOAM AND SEED SEED MIX 2
-  RESTORATION PLANTINGS
-  BIORETENTION AREA PLANTINGS
-  LANDSCAPE AREAS PLANTINGS
-  GATEWAYS PLANTING

**BARNSTABLE
MARSTONS MILLS VILLAGE CENTER IMPROVEMENTS**

SHEET NO.	TOTAL SHEETS
51	108

**LANDSCAPE PLANS (4)
SHEET 4 OF 8**

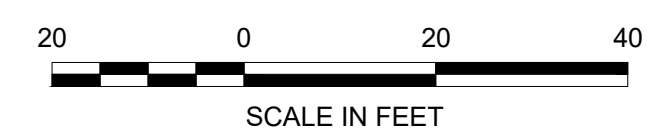
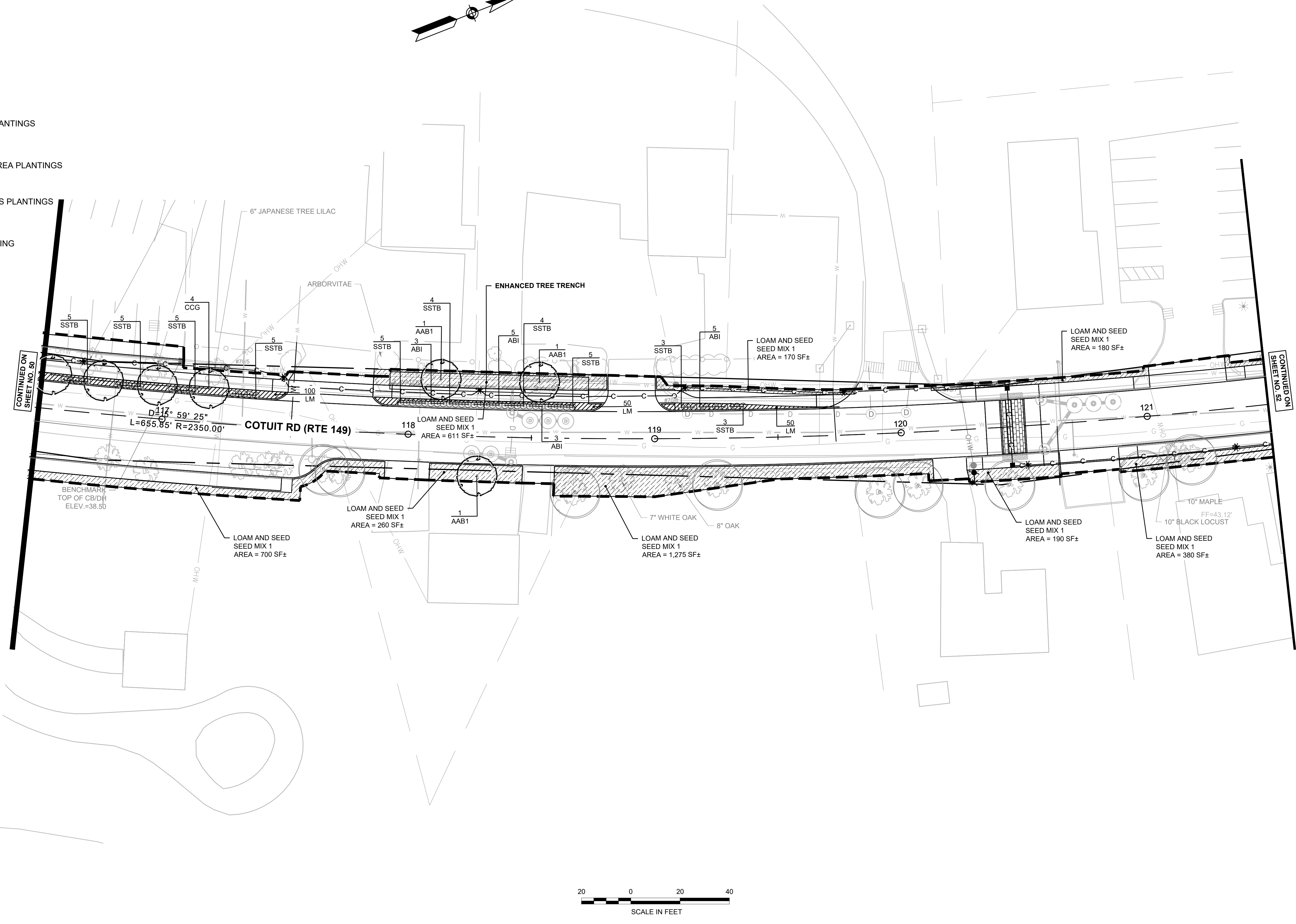
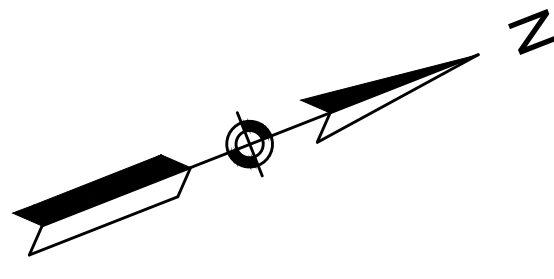



Landscape Plan 5 Plant List

Key	Qty	Botanical Name	Common Name	Size	Spacing	Notes
Trees						
CCG	2	<i>Crataegus crus-galli</i>	Cockspur Hawthorn	2-2.5" cal	As Shown	-

Gateway Node 3 Plant List

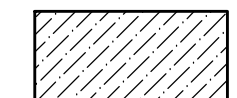
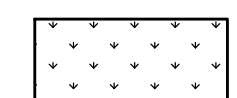
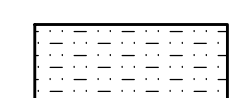
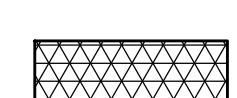
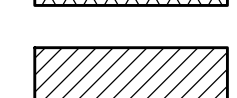
Key	Qty	Botanical Name	Common Name	Size	Spacing	Notes
Trees						
AAB	3	<i>Amelanchier X grandiflora 'Autumn Brilliance'</i>	Autumn Brilliance Serviceberry	7'-8" B&B	As Shown	multistem
Ground Cover/Grasses/Perennials						
AH	15	<i>Amsonia hubrichtii</i>	Thread-leaf Bluestar	#1	30" O.C.	-
CP	30	<i>Carex pensylvanica</i>	Pennsylvania Sedge	plugs	18" O.C.	-
ES	20	<i>Eragrostis spectabilis</i>	Purple Lovegrass	#1	30" O.C.	-
GR	23	<i>Geranium 'Rozanne'</i>	Rozanne Cranesbill	#1	18" O.C.	-
NB	25	<i>Narcissus 'Dutch Master'</i>	Daffodil Bulbs	bulbs	12" O.C.	-
OF	15	<i>Oenothera fruticosa</i>	Narrow-leaved Sundrops	#1	30" O.C.	-

-  LOAM AND SEED SEED MIX 1
-  LOAM AND SEED SEED MIX 2
-  RESTORATION PLANTINGS
-  BIORETENTION AREA PLANTINGS
-  LANDSCAPE AREAS PLANTINGS
-  GATEWAYS PLANTING

**BARNSTABLE
MARSTONS MILLS VILLAGE CENTER IMPROVEMENTS**

SHEET NO.	TOTAL SHEETS
52	108

**LANDSCAPE PLANS (5)
SHEET 5 OF 8**

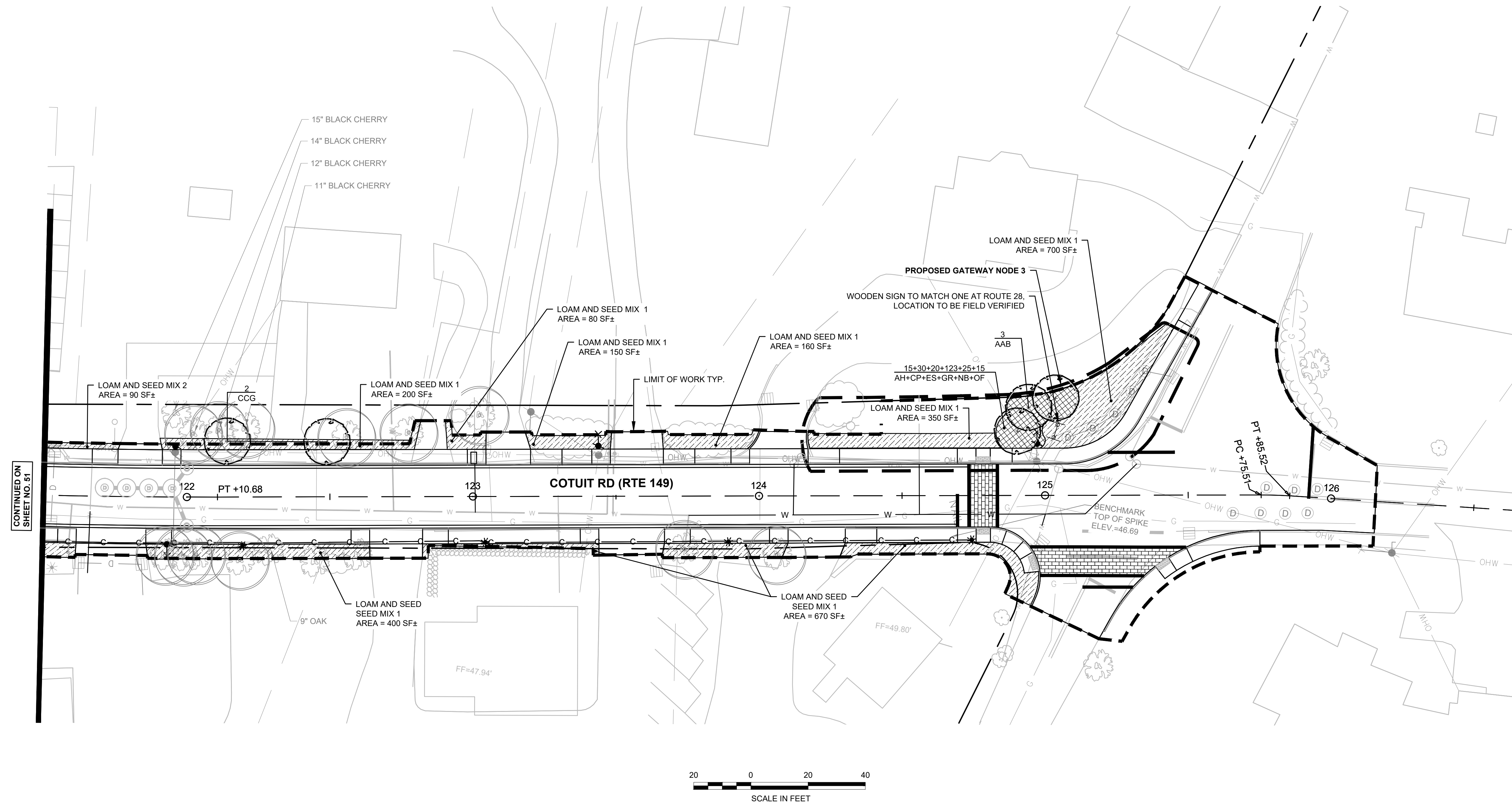
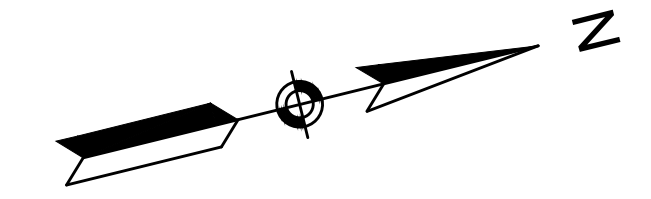

CONTINUED ON SHEET NO. 51

Landscape Plan 6 Plant List



Key	Qty	Botanical Name	Common Name	Size	Spacing	Notes
Trees						
ARR	1	<i>Acer rubrum 'Red Sunset'</i>	Red Sunset Red Maple	2.5-3" cal.	As Shown	-
CCG	1	<i>Crataegus crus-galli</i>	Cockspur Hawthorn	2-2.5" cal	As Shown	-
LST	2	<i>Liquidambar styraciflua</i>	Sweet Gum	2.5"-3" cal.	As Shown	-

**BARNSTABLE
MARSTONS MILLS VILLAGE CENTER IMPROVEMENTS**

SHEET NO.	TOTAL SHEETS
53	108

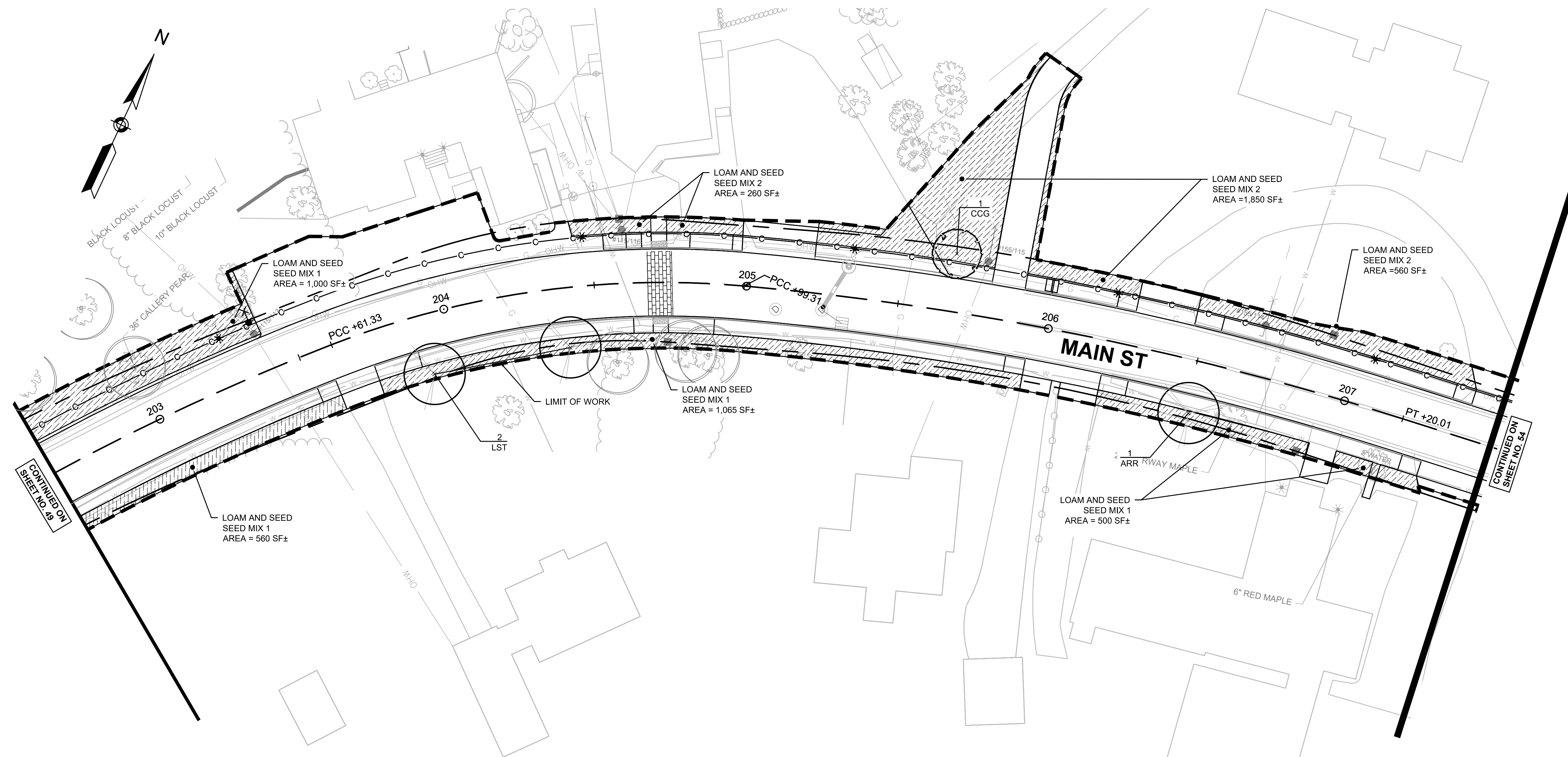
**LANDSCAPE PLANS (6)
SHEET 6 OF 8**



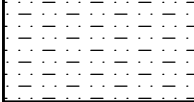
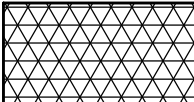
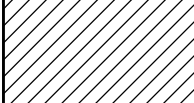
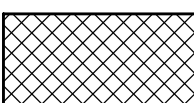

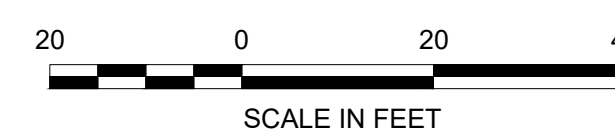
-  LOAM AND SEED SEED MIX 1
-  LOAM AND SEED SEED MIX 2
-  RESTORATION PLANTINGS
-  BIORETENTION AREA PLANTINGS
-  LANDSCAPE AREAS PLANTINGS
-  GATEWAYS PLANTING

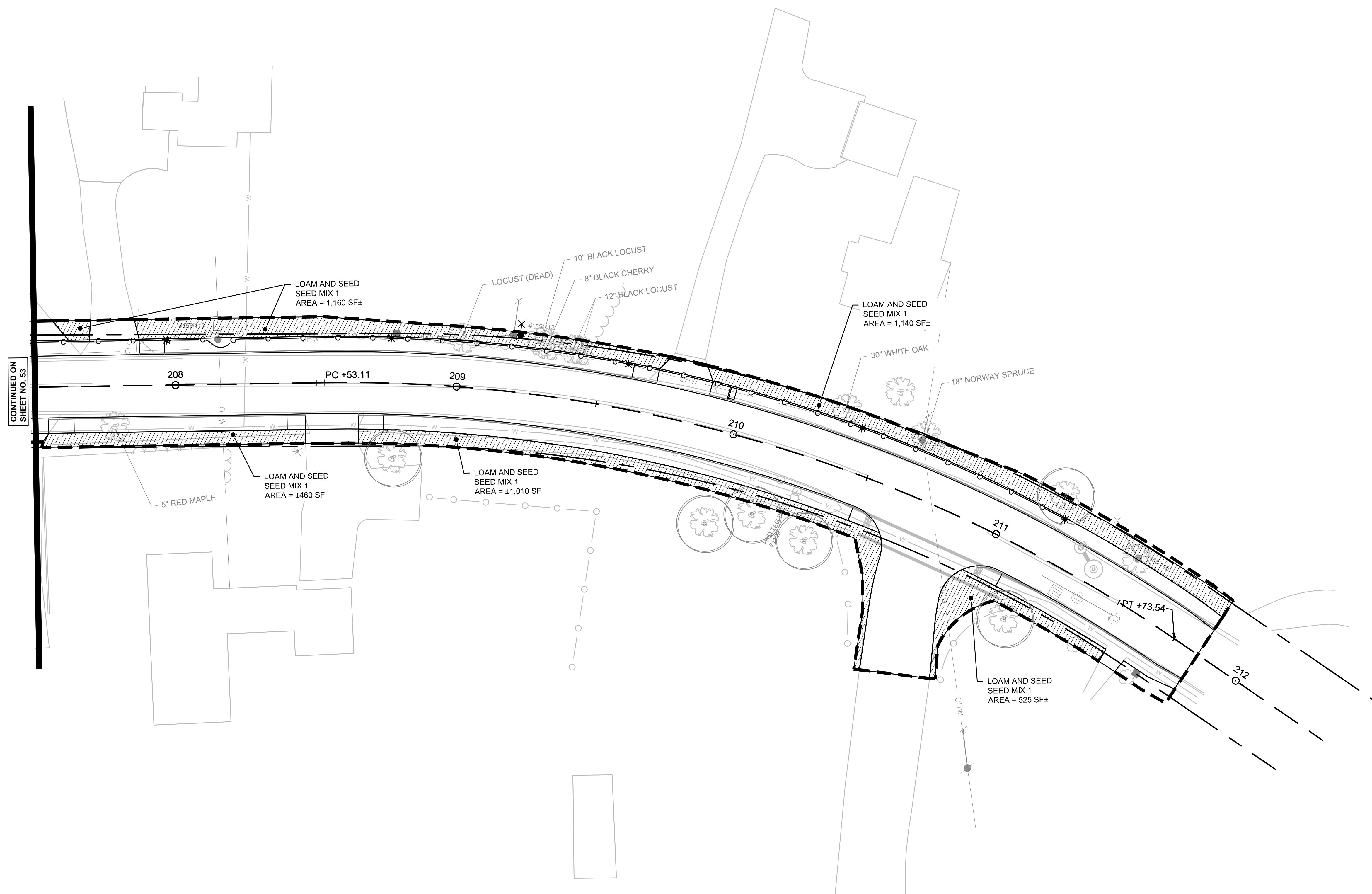
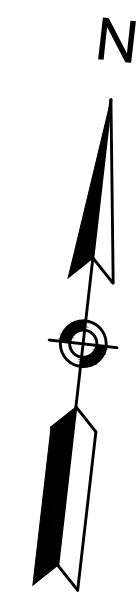

SHEET NO.	TOTAL SHEETS
54	108

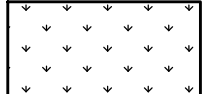
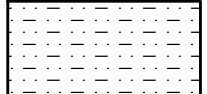
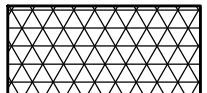

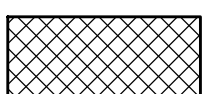
-  LOAM AND SEED SEED MIX 1
-  LOAM AND SEED SEED MIX 2
-  RESTORATION PLANTINGS
-  BIORETENTION AREA PLANTINGS
-  LANDSCAPE AREAS PLANTINGS
-  GATEWAYS PLANTING

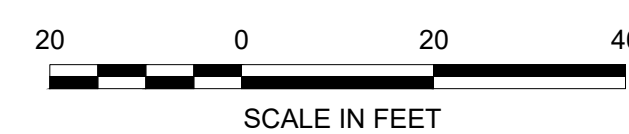

SHEET NO.	TOTAL SHEETS
55	108

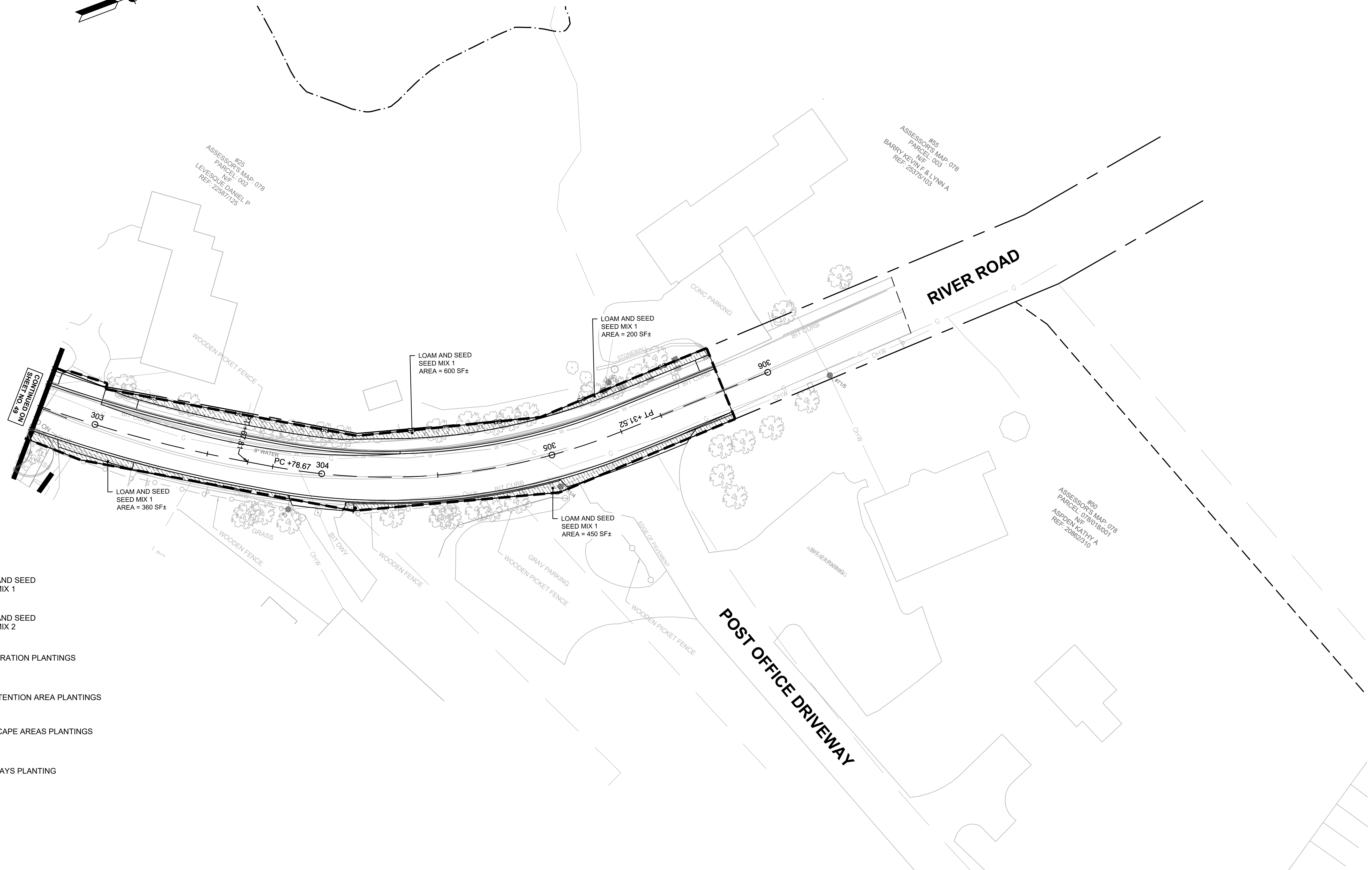
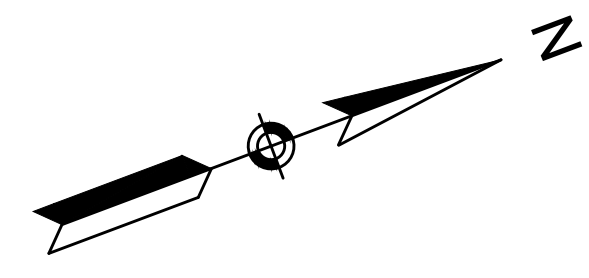

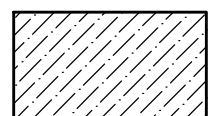
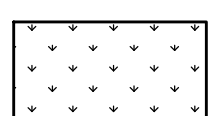
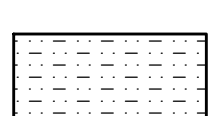
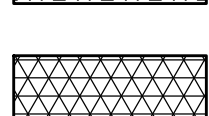
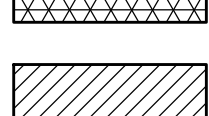
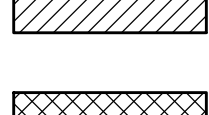
-  LOAM AND SEED SEED MIX 1
-  LOAM AND SEED SEED MIX 2
-  RESTORATION PLANTINGS
-  BIORETENTION AREA PLANTINGS
-  LANDSCAPE AREAS PLANTINGS
-  GATEWAYS PLANTING



**BARNSTABLE
MARSTONS MILLS VILLAGE CENTER IMPROVEMENTS**

SHEET NO.	TOTAL SHEETS
56	109

**LIGHTING PLAN
SHEET 1 OF 8**

REV #	DATE
△	11/28/18
△	3/13/19

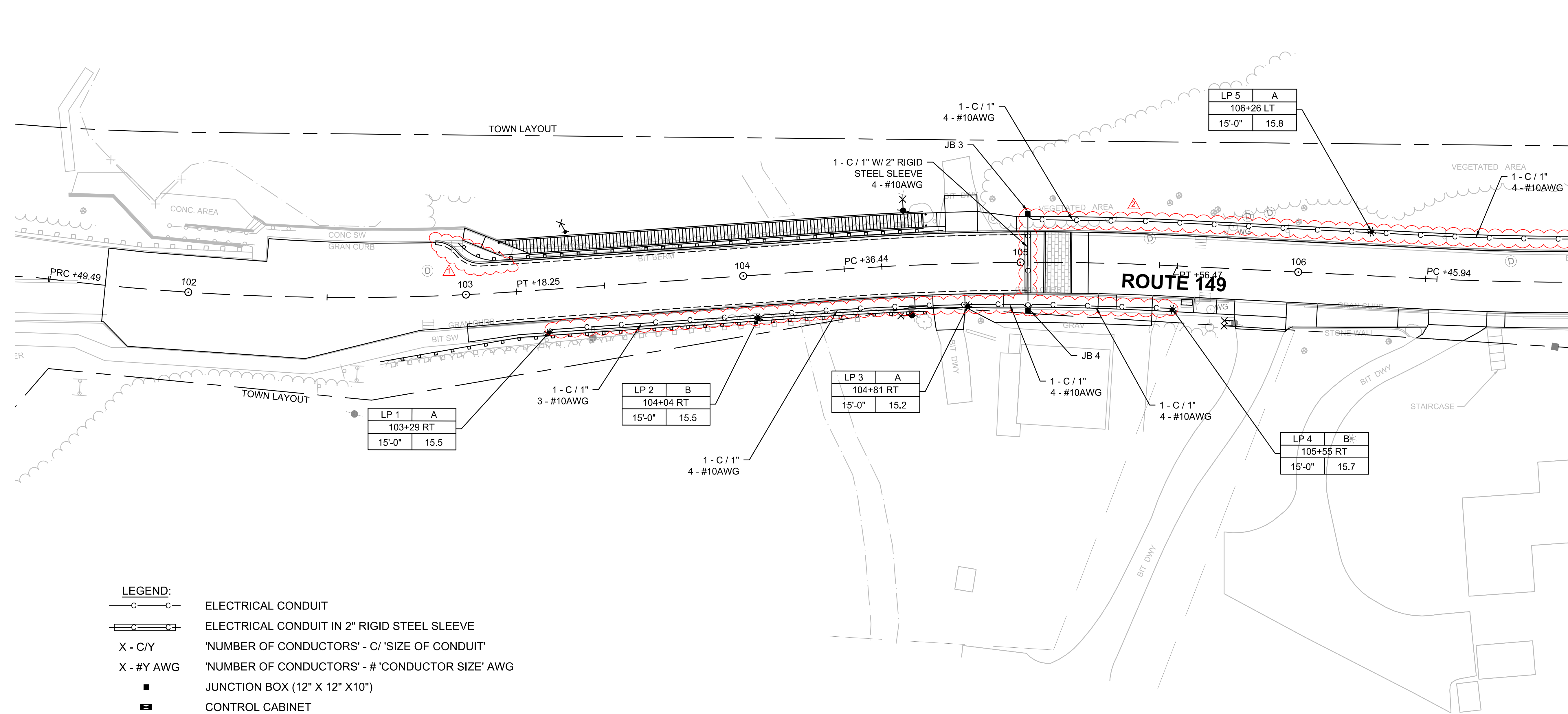
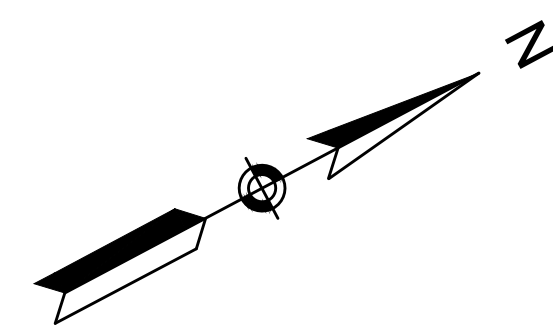

CONTINUED ON
SHEET NO. 57

LEGEND:

- ELECTRICAL CONDUIT
- ELECTRICAL CONDUIT IN 2" RIGID STEEL SLEEVE
- X - C/Y 'NUMBER OF CONDUCTORS' - C/ 'SIZE OF CONDUIT'
- X - #Y AWG 'NUMBER OF CONDUCTORS' - # 'CONDUCTOR SIZE' AWG
- JUNCTION BOX (12" X 12" X 10")
- ▣ CONTROL CABINET
- ★ 15'-0" ALUMINUM POLE W/ 35 WATT LED PENDENT LUMINAIRE

LUMINAIRE ID #	CIRCUIT ID
STATION	
MOUNTING HEIGHT	OFFSET



**BARNSTABLE
MARSTONS MILLS VILLAGE CENTER IMPROVEMENTS**

SHEET NO.	TOTAL SHEETS
57	109

**LIGHTING PLAN
SHEET 2 OF 8**

REV #	DATE
1	3/13/19

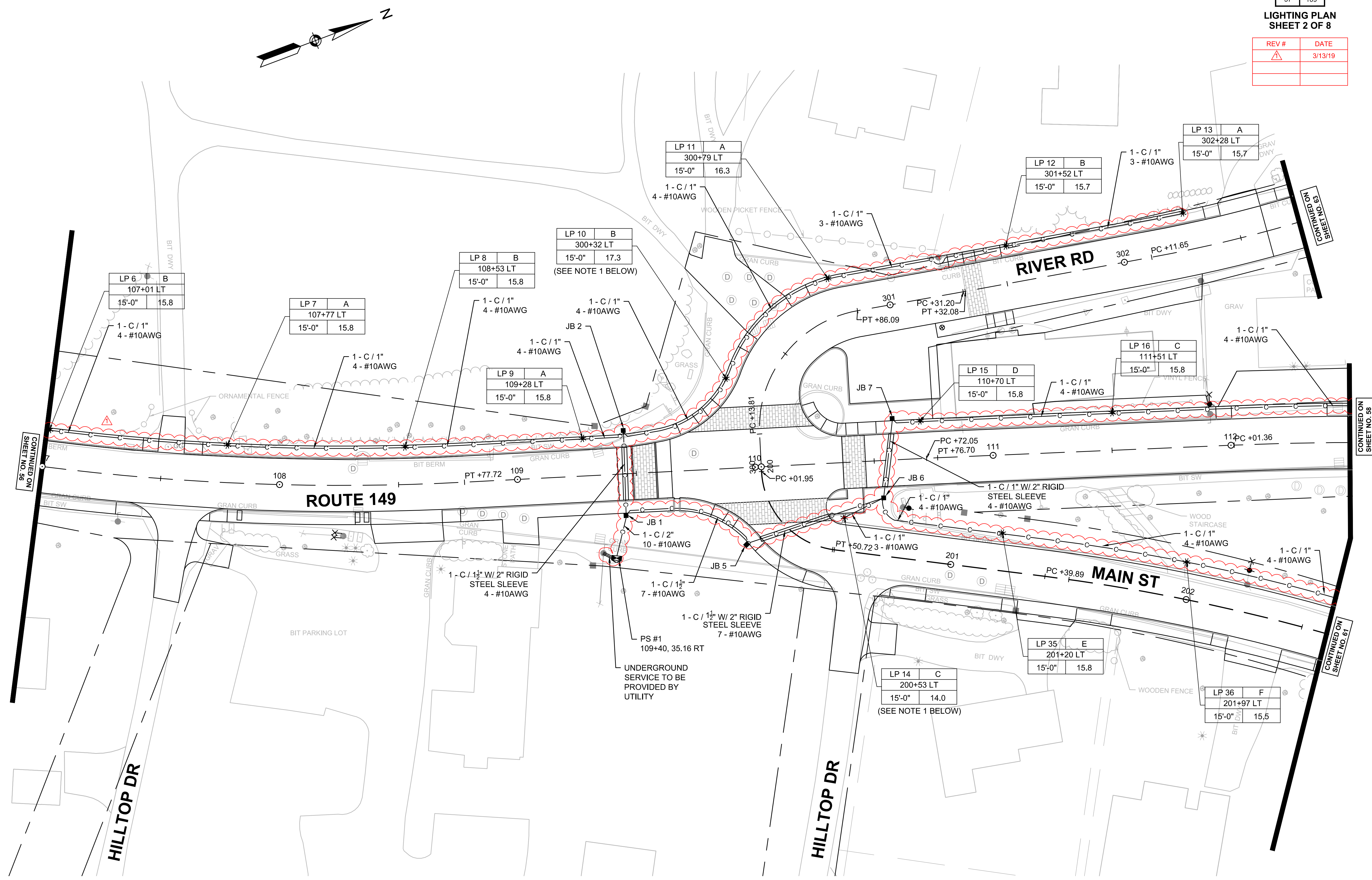

NOTE:

- ALL LIGHT FIXTURES SHALL BE ORIENTED PERPENDICULAR TO THE CENTERLINE OF THE ROADWAY, WITH THE FOLLOWING EXCEPTIONS:
 - THE LIGHT FIXTURE ON LP 10 SHALL BE ORIENTED AT 64 DEGREES CLOCKWISE OF TRUE NORTH.
 - THE LIGHT FIXTURE ON LP 14 SHALL BE ORIENTED AT 163 DEGREES CLOCKWISE OF TRUE NORTH.



BARNSTABLE
MARSTONS MILLS VILLAGE CENTER IMPROVEMENTS

SHEET NO.	TOTAL SHEETS
58	109

LIGHTING PLAN
SHEET 3 OF 8

REV #	DATE
△	3/13/19

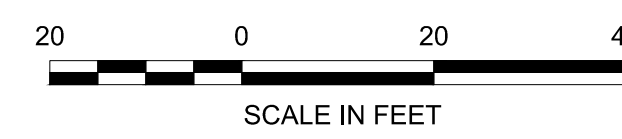
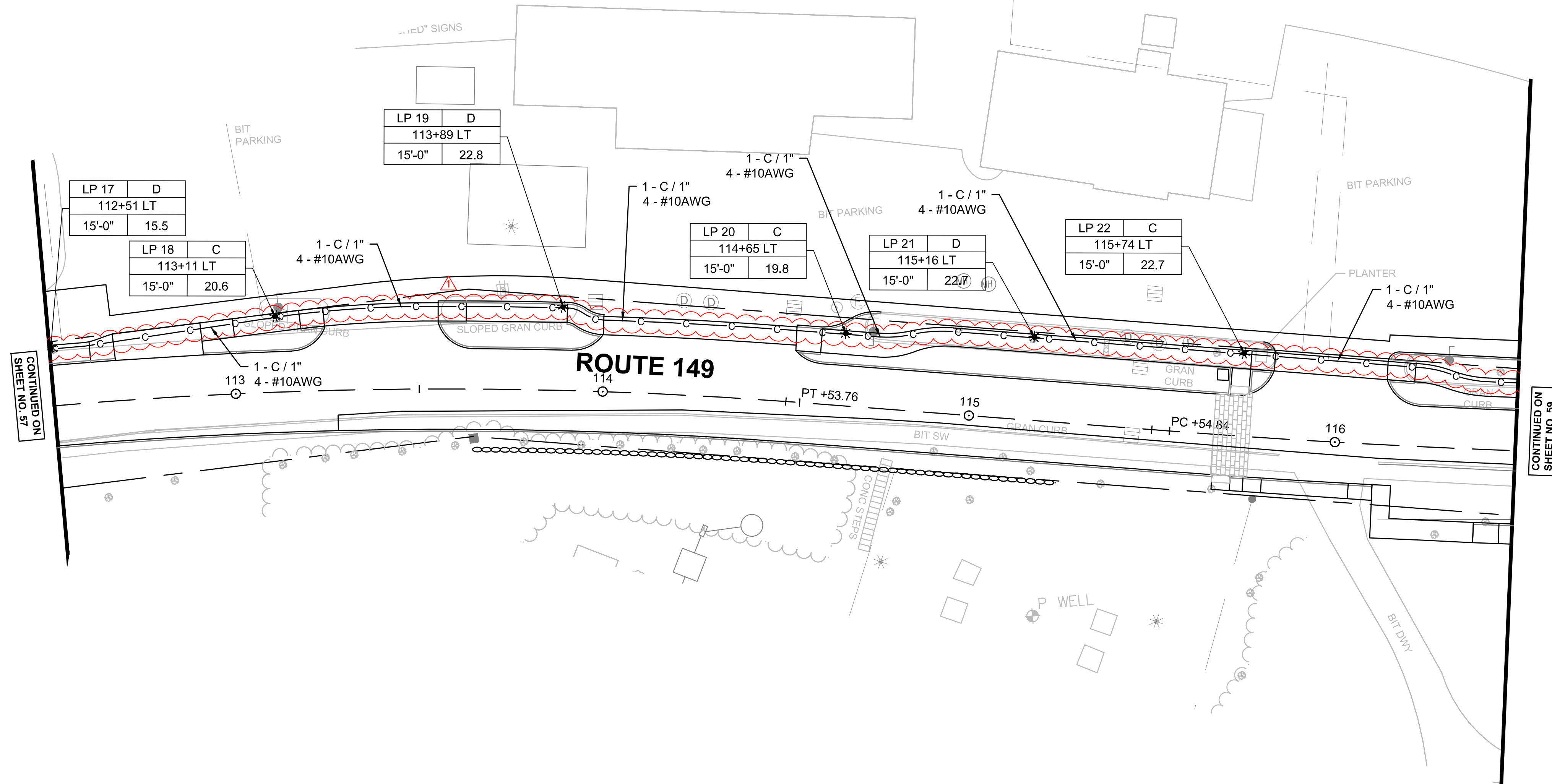
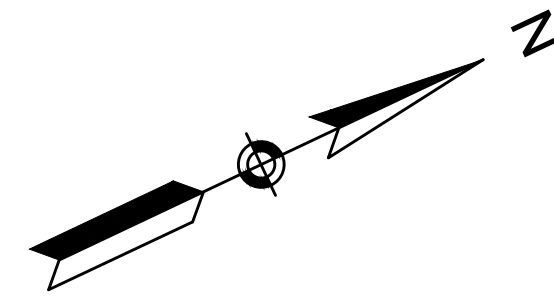

BARNSTABLE
MARSTONS MILLS VILLAGE CENTER IMPROVEMENTS

SHEET NO.	TOTAL SHEETS
59	109

LIGHTING PLAN
SHEET 4 OF 8

REV #	DATE
△	3/13/19

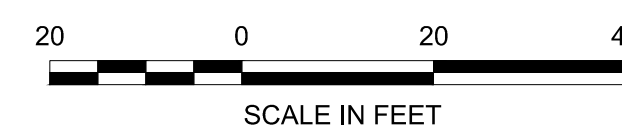

CONTINUED ON
SHEET NO. 58

CONTINUED ON
SHEET NO. 60

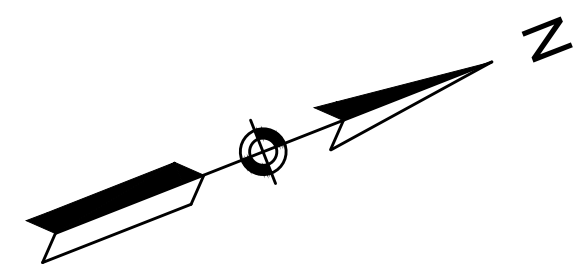

BARNSTABLE
MARSTONS MILLS VILLAGE CENTER IMPROVEMENTS

SHEET NO.	TOTAL SHEETS
60	109

LIGHTING PLAN
SHEET 5 OF 8

REV #	DATE
△	3/13/19

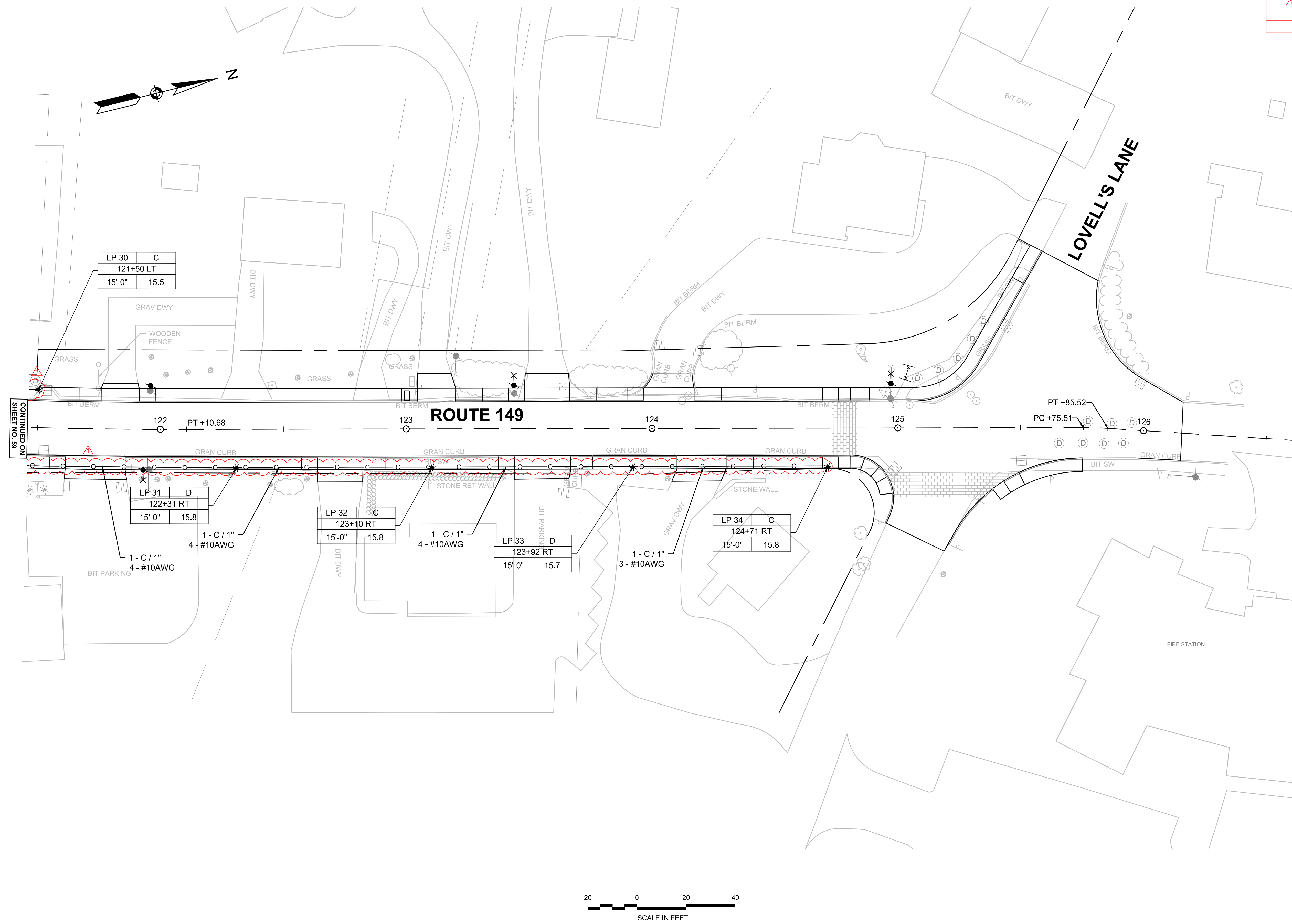

CONTINUED ON
SHEET NO. 59

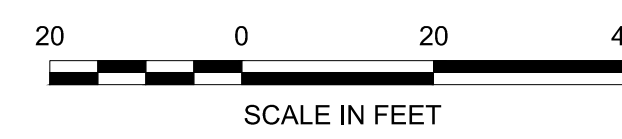

BARNSTABLE
MARSTONS MILLS VILLAGE CENTER IMPROVEMENTS

SHEET NO.	TOTAL SHEETS
61	109

LIGHTING PLAN
SHEET 6 OF 8

REV #	DATE
△	3/13/19

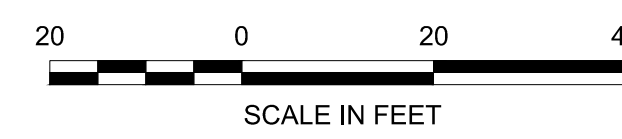
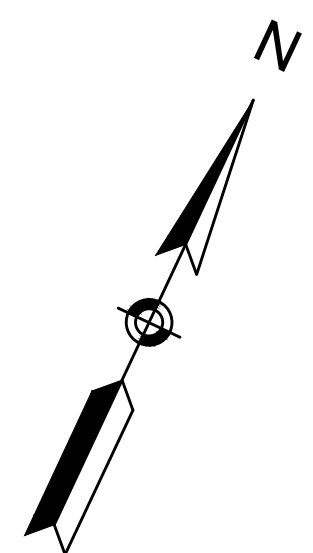
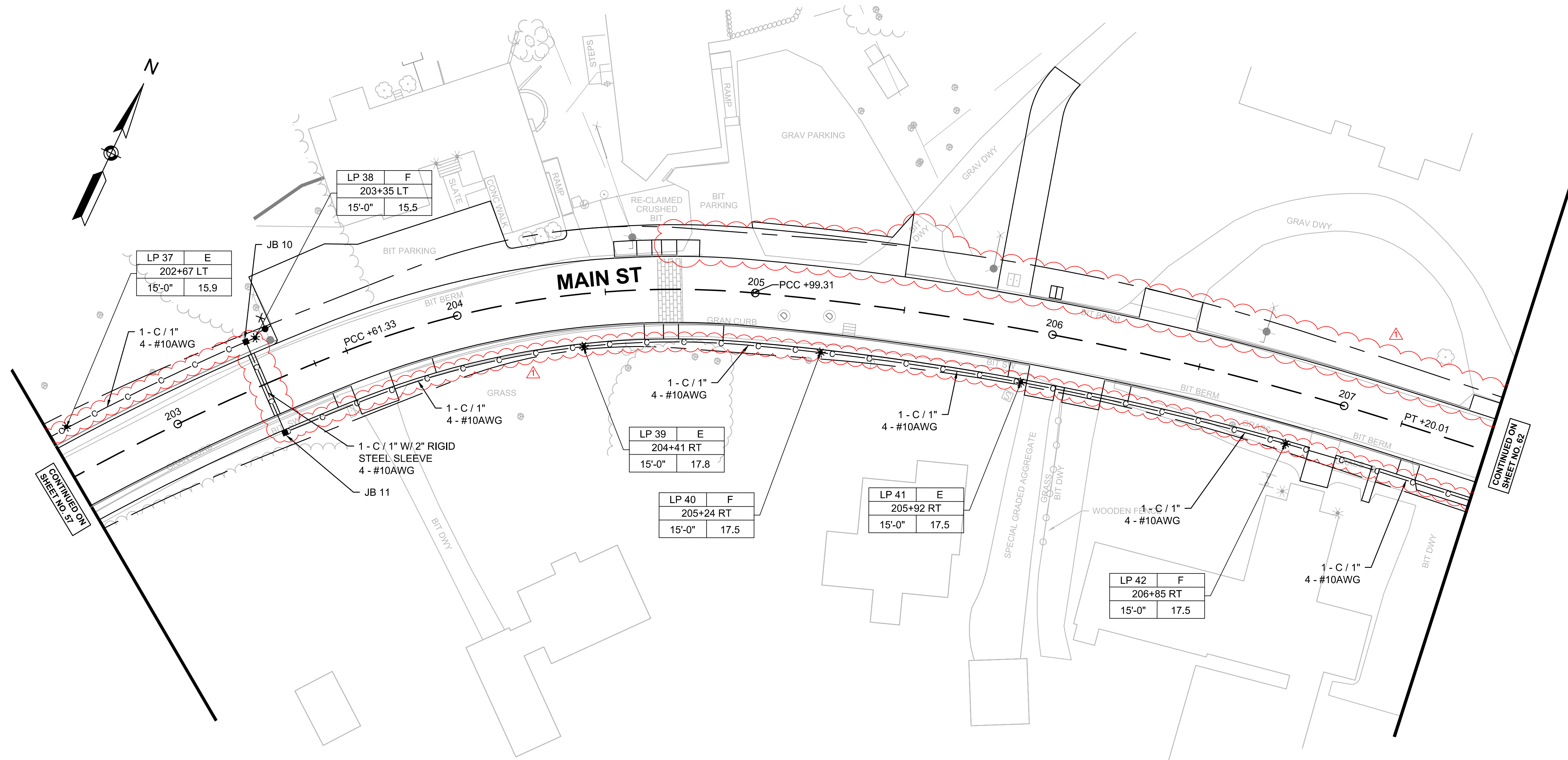

CONTINUED ON
SHEET NO. 57

CONTINUED ON
SHEET NO. 62

BARNSTABLE
MARSTONS MILLS VILLAGE CENTER IMPROVEMENTS

SHEET NO.	TOTAL SHEETS
62	109

LIGHTING PLAN
SHEET 7 OF 8

REV #	DATE
△	3/13/19

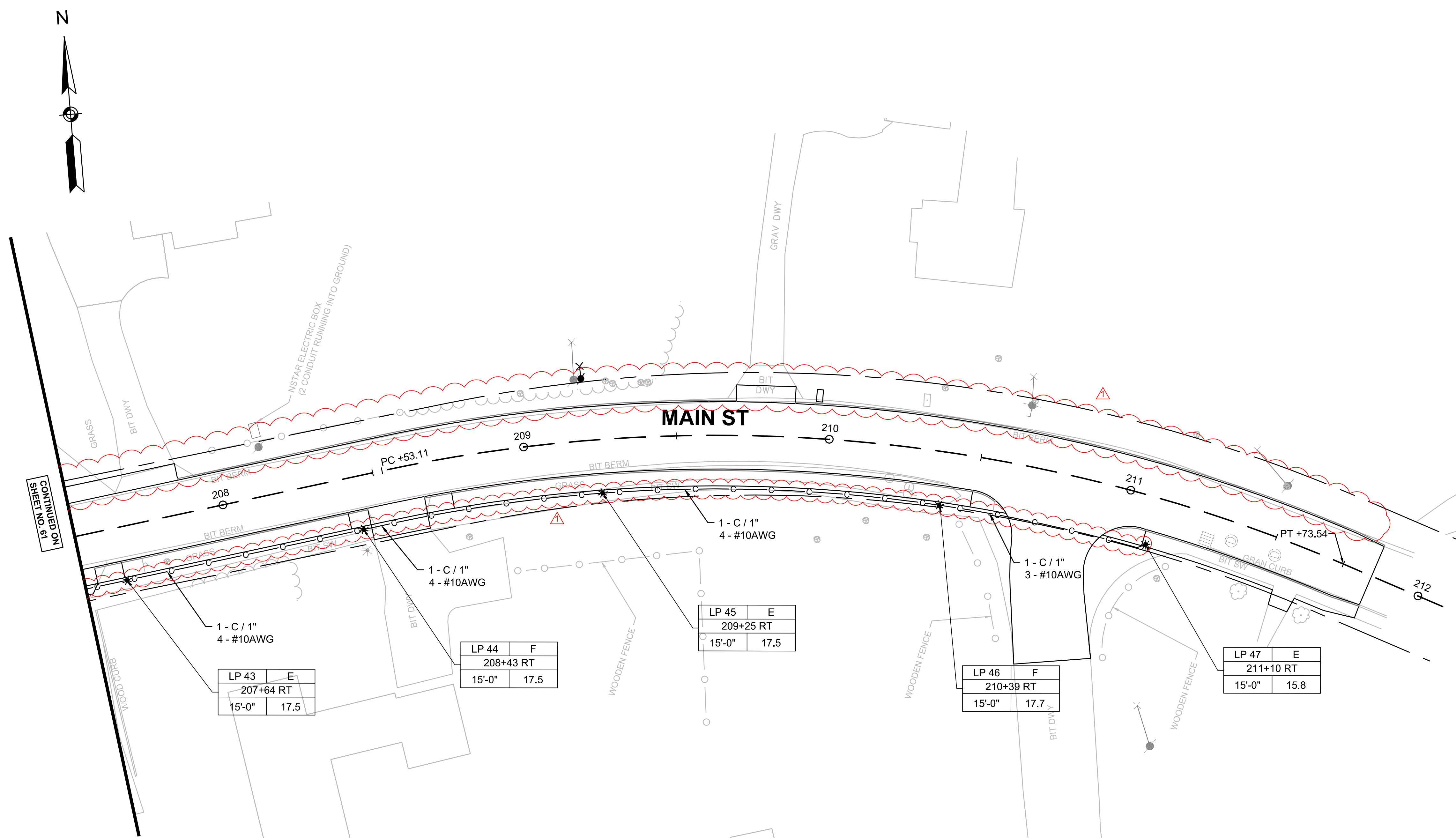

CONTINUED ON
SHEET NO. 61

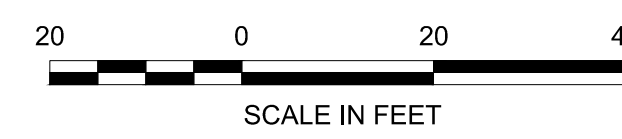

BARNSTABLE
MARSTONS MILLS VILLAGE CENTER IMPROVEMENTS

SHEET NO.	TOTAL SHEETS
63	109

LIGHTING PLAN
SHEET 8 OF 8

12874 - LIGHTING.DWG 12-Mar-2019



NOTE: THERE ARE NO PROPOSED LIGHT FIXTURES OR CONDUIT ON THIS SHEET.



**BARNSTABLE
MARSTONS MILLS VILLAGE CENTER IMPROVEMENTS**

SHEET NO.	TOTAL SHEETS
64	109

LIGHTING SCHEMATICS

REV #	DATE
△	3/5/19

LEGEND:

○ 35 WATT LED PENDANT LUMINAIRE

▭ JB

POWER SUPPLY 1 (PS #1)
STA 109+40, 35.16' RT

C N D

JB 1

JB 5

JB 6

JB 7

JB 1

JB 5

JB 6

JB 7

LP #15

LP #16

LP #17

LP #18

LP #19

LP #20

LP #21

LP #22

LP #23

LP #24

LP #25

LP #26

LP #27

LP #28

LP #29

LP #32

LP #31

LP #34

LP #33

LP #34

LP #33

POWER SUPPLY 1 (PS #1)
STA 109+40, 35.16' RT

E N F

JB 1

JB 5

JB 6

JB 1

JB 5

JB 6

LP #35

LP #36

LP #37

LP #38

LP #39

LP #40

LP #41

LP #42

LP #43

LP #44

LP #45

LP #46

LP #47

LP #46

POWER SUPPLY 1 (PS #1)
STA 109+40, 35.16' RT

A N B

JB 1

JB 2

LP #11

LP #13

LP #10

LP #12

LP #8

LP #6

LP #2

LP #4

LP #2

LP #9

LP #7

LP #5

LP #3

LP #1

LP #1

LP #1

LP #29

LP #30

LP #31

LP #33

LP #33

LP #33

LP #33

LP #33

LP #33

LP #33

LP #33

SHEET NO.	TOTAL SHEETS
65	109

LIGHTING DETAILS

REV #	DATE
1	3/5/19

POLE MOUNTED CABINET
SUBSTITUTED WITH
PAD MOUNTED CABINET

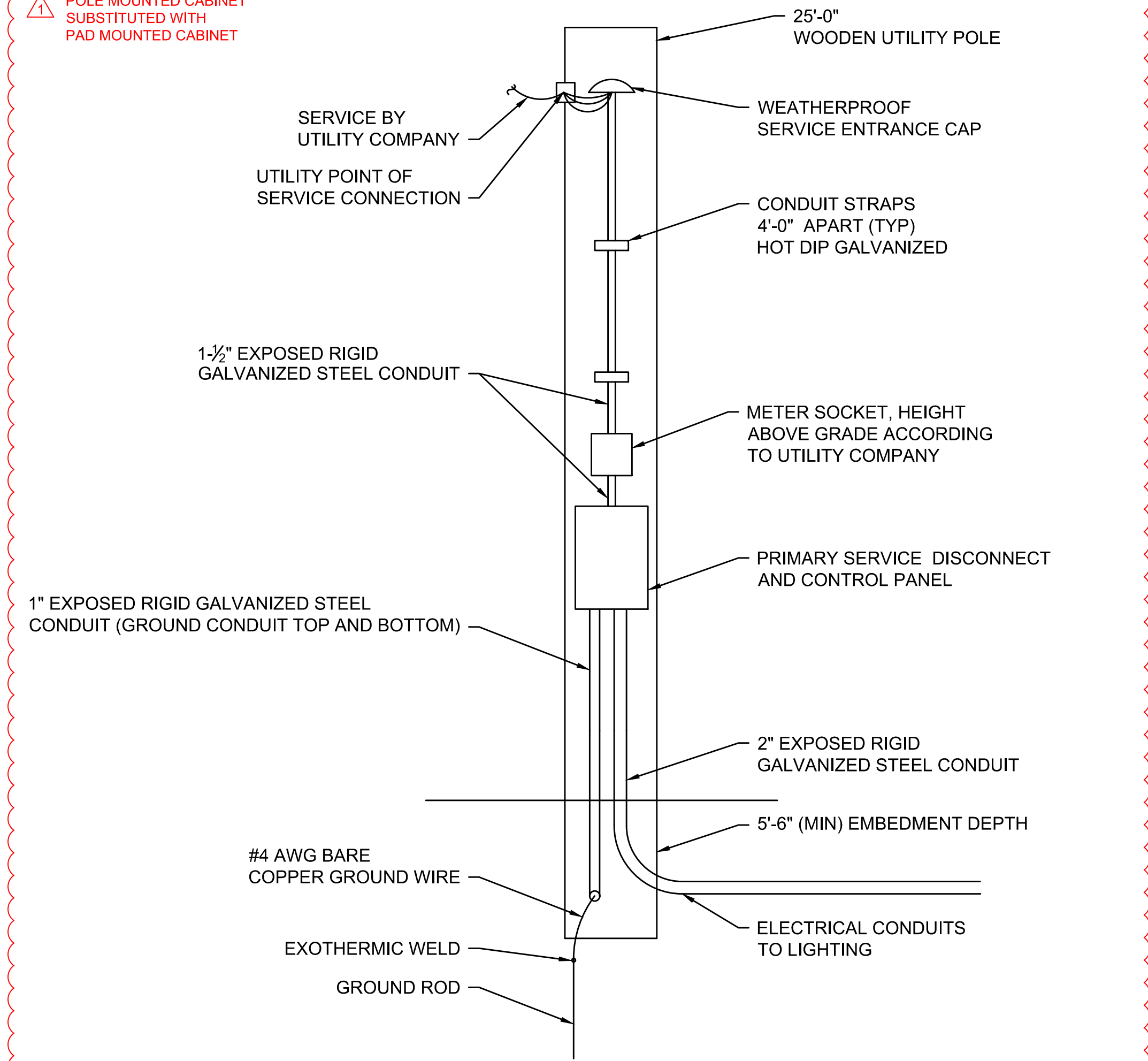

NOTES:

- ASSEMBLE IN A WAY TO BE SERVICE ENTRANCE RATED AND LABELED "SERVICE DISCONNECT". PROVIDE LOCKING MECHANISM FOR MAIN DISCONNECT SWITCH. COORDINATE WITH THE REPRESENTATIVE.
- INSTALL SO THAT METER PANEL FACES OR DIRECTION FROM WHICH THE UTILITY WILL APPROACH THE SERVICE.
- INSTALLATION REQUIREMENTS MAY VARY BY UTILITY COMPANY. COORDINATE WITH UTILITY FOR INSTALLATION REQUIREMENTS.
- TRANSITION FROM GRS TO PVC CONDUIT WITHIN 6" OF THE GROUND ON SERVICE POLE.
- TRANSITION CONDUIT FROM 2'-0" (MIN) DEPTH AT THE POLE TO 3'-0" (MIN) DEPTH BASED ON THE CABLE BENDING RADIUS FOR ALL CONDUIT RUNS.

CONTROL CABINET ASSEMBLY DETAIL

NOT TO SCALE

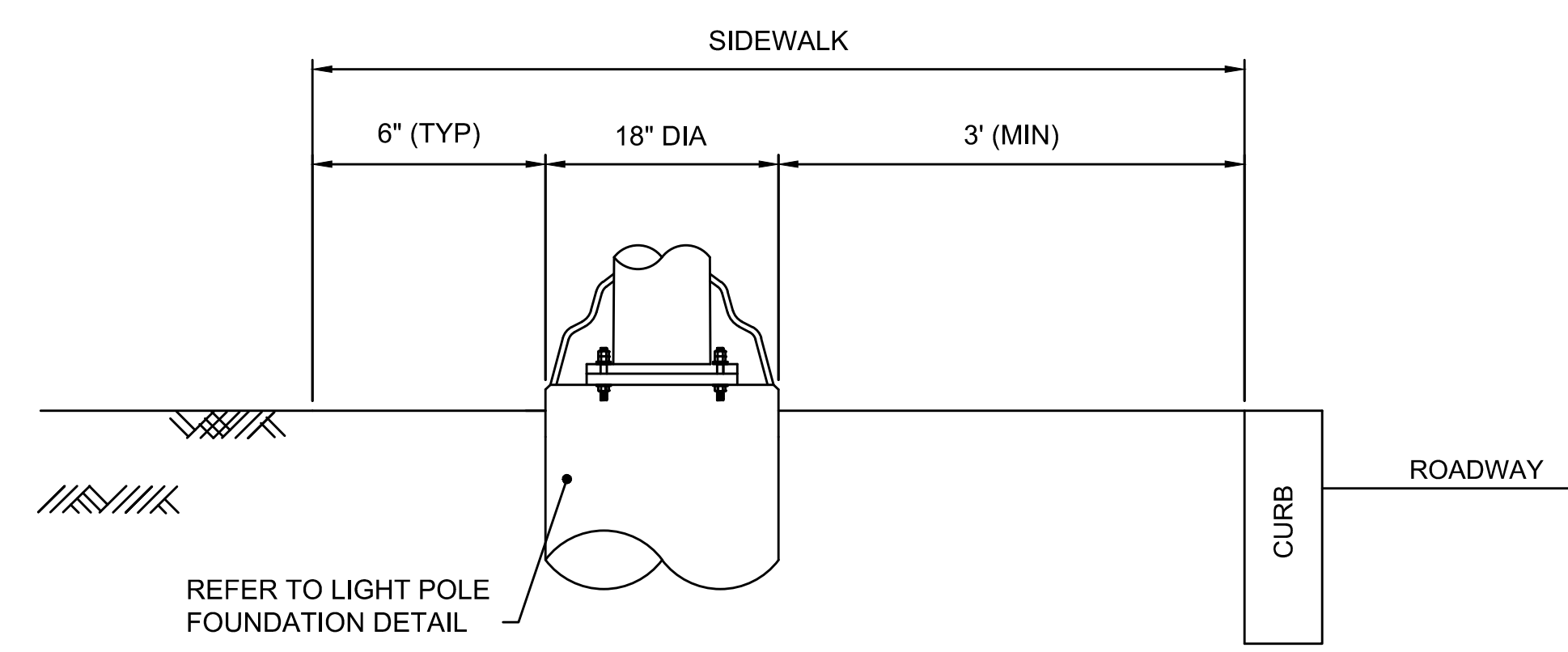

LIGHT POLE PLACEMENT IN SIDEWALK DETAIL

NOT TO SCALE

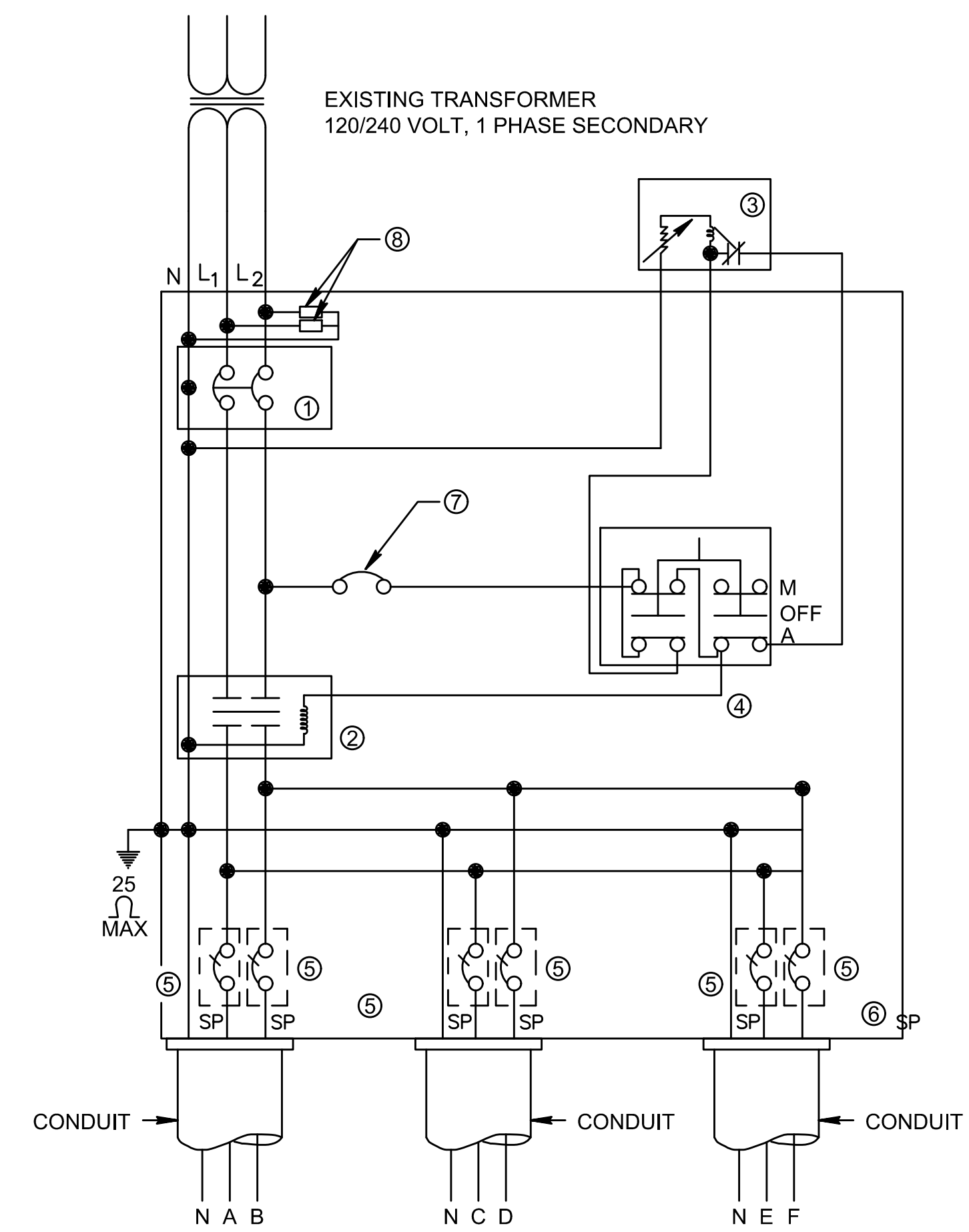

POWER SUPPLY NO	SYSTEM VOLTAGE	1 MAIN CIRCUIT BREAKER D.P.	2 CONTROL CONTACTOR	CIRCUIT	5 DISTRIBUTION BREAKER S.P.
1	120/240 V	60A	60A	A/B	20A
				C/D	20A
				E/F	20A

LEGEND:

- N - NEUTRAL
- L - LINE 1
- L - LINE 2
- M - MANUAL
- N - AUTOMATIC
- SP - SINGLE POST
- DP - DOUBLE POST
- ① - MAIN CONTROL CABINET CIRCUIT BREAKERS - 60A, DP (10,000 AIC, MIN.)
- ② - CONTROL CONTACTOR - 60A, DP
- ③ - PHOTOELECTRIC CELL (PLUG-IN TYPE)
- ④ - SELECTOR SWITCH
- ⑤ - DISTRIBUTION BREAKERS - 20A, SP (10,000 AIC)
- ⑥ - CONTROL CABINET
- ⑦ - 20A, SP BREAKER
- ⑧ - LIGHTNING ARRESTER

NOTE:

PROVIDE A DISCONNECT BREAKER THAT IS SERVICE RATED, IN A SEPARATE NEMA 3R OR NEMA 4 ENCLOSURE AHEAD OF THE CONTROL CABINET AND MARKED "SUITABLE FOR USE AS SERVICE EQUIPMENT." PROVIDE AS A SEPARATE UNIT OUTSIDE THE MAIN ENCLOSURE WITH A LOCKABLE COVER AND NO EXTERNAL HANDLE. THE DISCONNECT MAY BE PROVIDED INTEGRAL TO THE CONTROL CABINET IF THE CABINET IS DEAD FRONT AND LABELED AS "SUITABLE FOR USE AS SERVICE EQUIPMENT."

TYPICAL CONTROL CABINET SCHEMATIC WIRING DIAGRAM

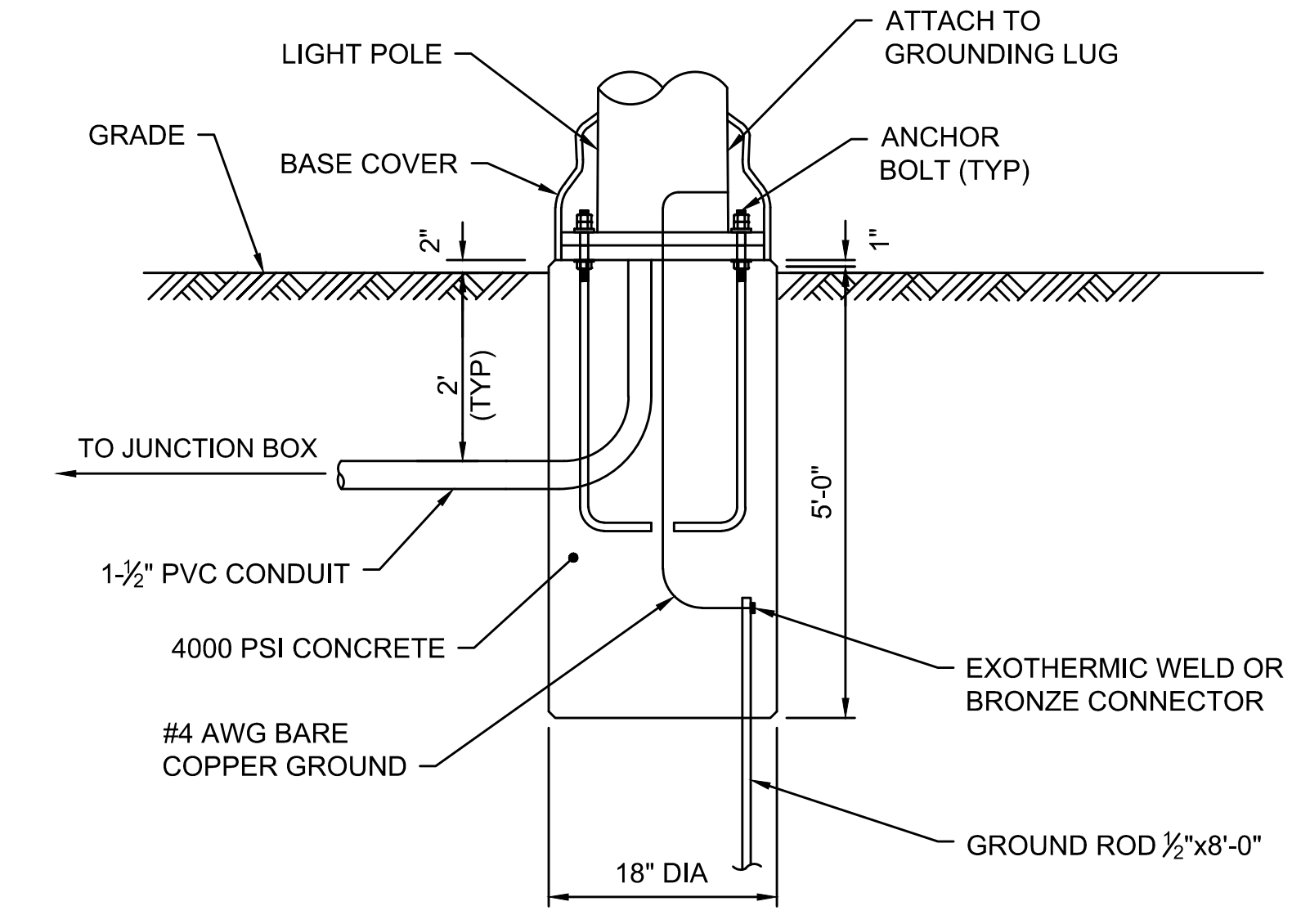

NOTES:

- FOUNDATION DEPTH PER LIGHT POLE MANUFACTURER'S RECOMMENDATION.
- ANCHOR BOLTS AND ANCHOR BOLT HARDWARE SIZED PER LIGHT POLE MANUFACTURER'S RECOMMENDATION.

LIGHT POLE FOUNDATION

NOT TO SCALE

**BARNSTABLE
MARSTONS MILLS VILLAGE CENTER IMPROVEMENTS**

SHEET NO.	TOTAL SHEETS
66	109

**TRAFFIC SIGNS AND PAVEMENT MARKING PLAN
SHEET 1 OF 8**

REV #	DATE
1	11/28/18

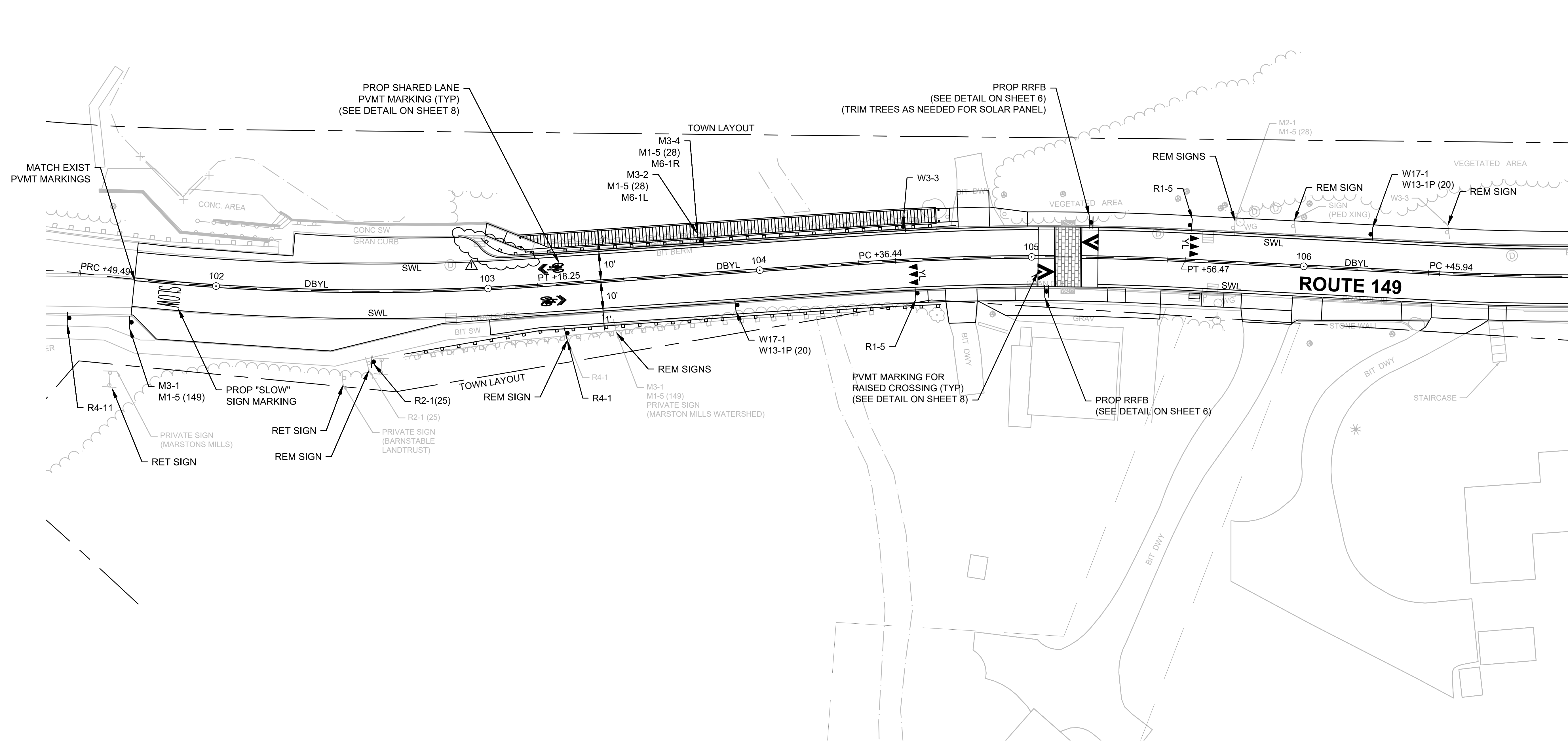
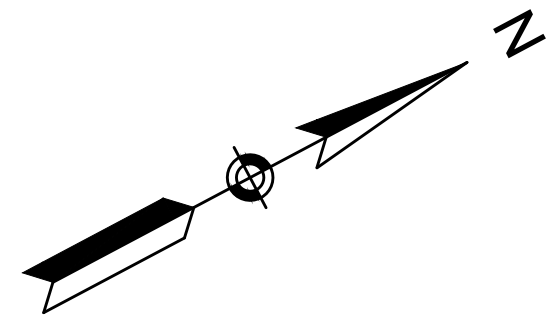

CONTINUED ON SHEET NO. 67

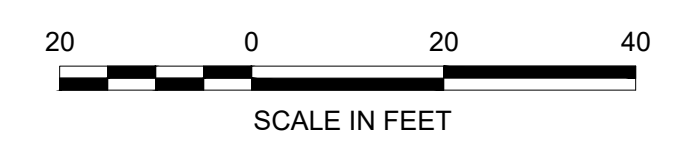

BARNSTABLE
MARSTONS MILLS VILLAGE CENTER IMPROVEMENTS

SHEET NO.	TOTAL SHEETS
67	109

TRAFFIC SIGNS AND PAVEMENT MARKING PLAN
SHEET 2 OF 8

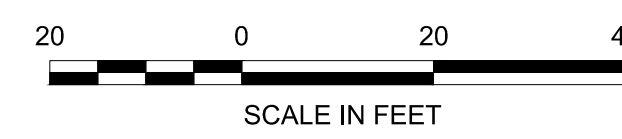
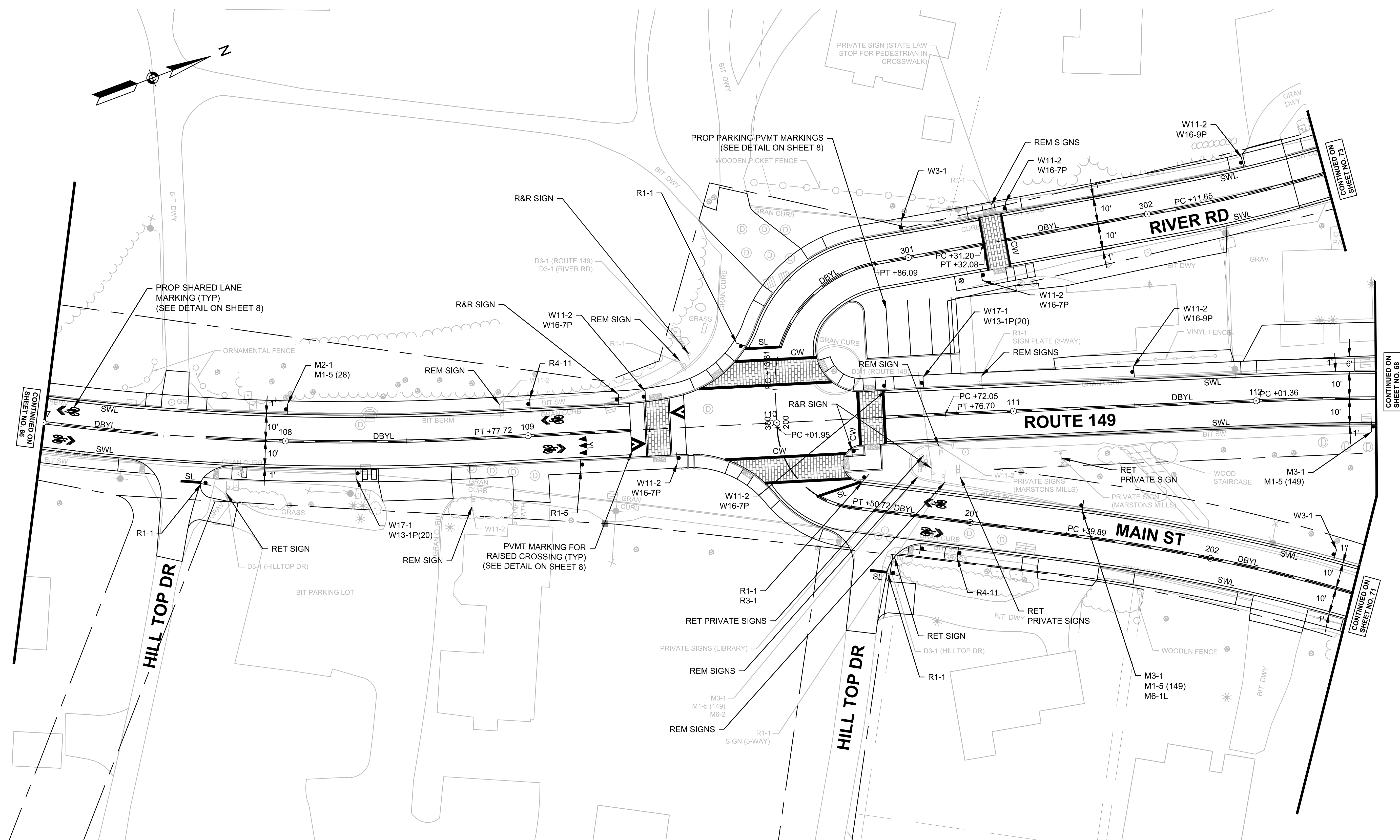

CONTINUED ON SHEET NO. 68

CONTINUED ON SHEET NO. 68

CONTINUED ON SHEET NO. 71

BARNSTABLE
MARSTONS MILLS VILLAGE CENTER IMPROVEMENTS

SHEET NO.	TOTAL SHEETS
68	109

TRAFFIC SIGNS AND PAVEMENT MARKING PLAN
SHEET 3 OF 8

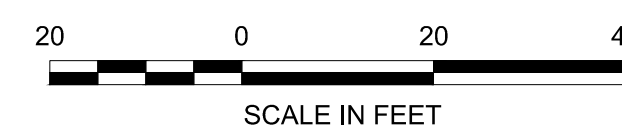
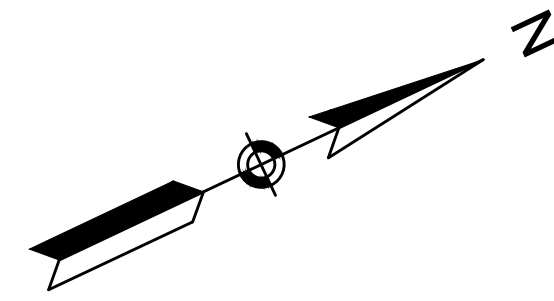
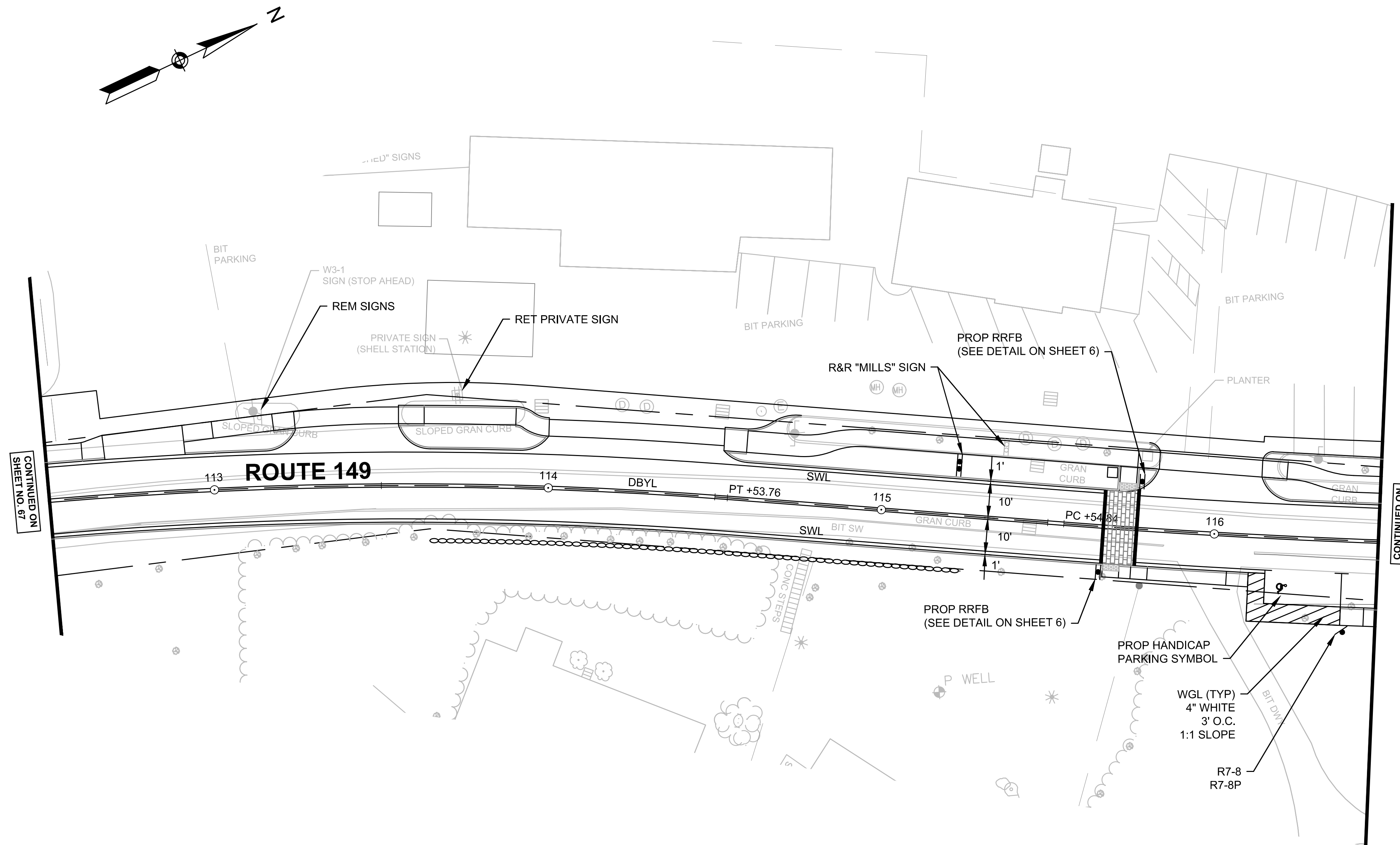

CONTINUED ON SHEET NO. 67

CONTINUED ON SHEET NO. 69

SHEET NO.	TOTAL SHEETS
69	109

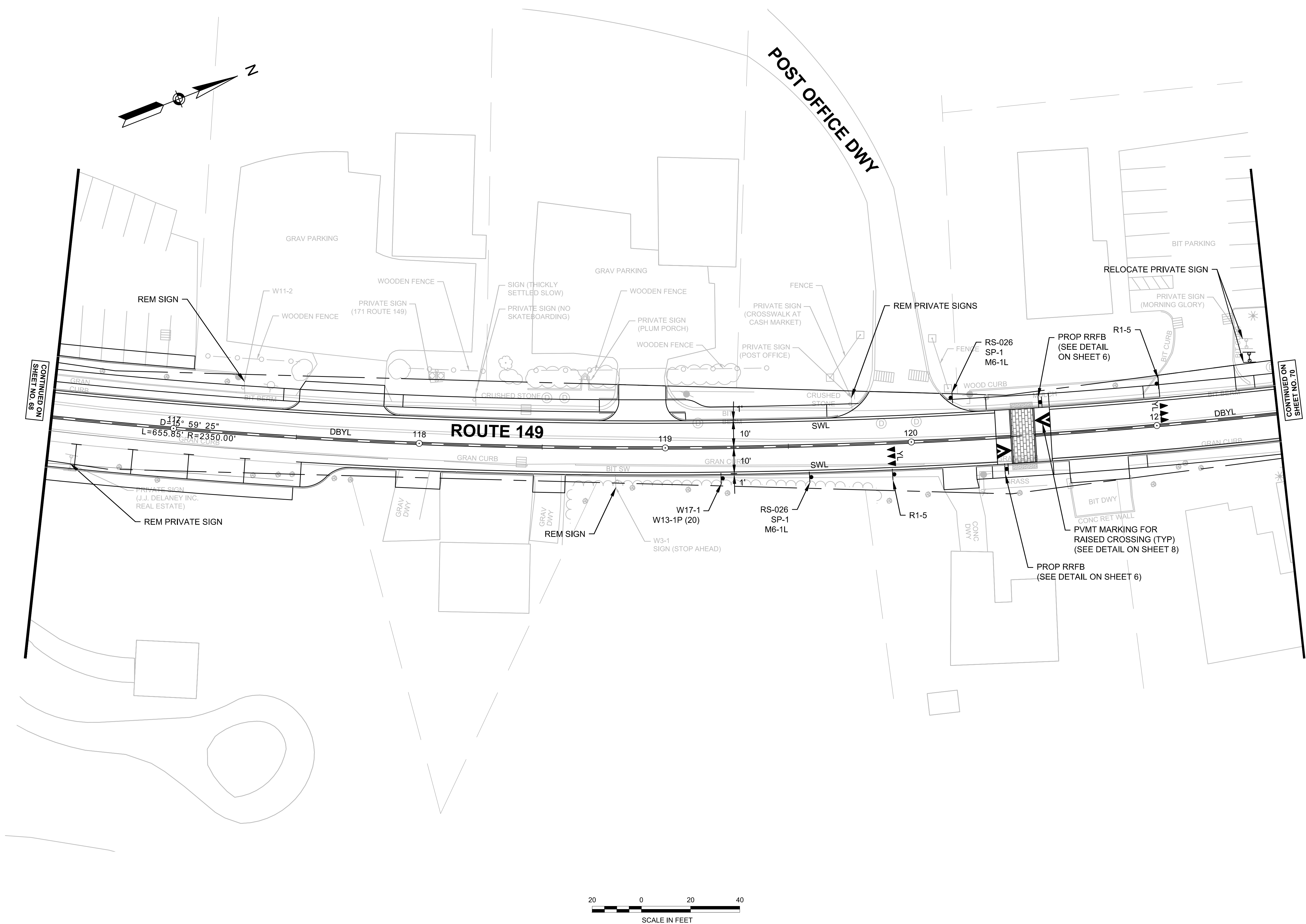

CONTINUED ON SHEET NO. 68

CONTINUED ON SHEET NO. 70

SHEET NO.	TOTAL SHEETS
70	109

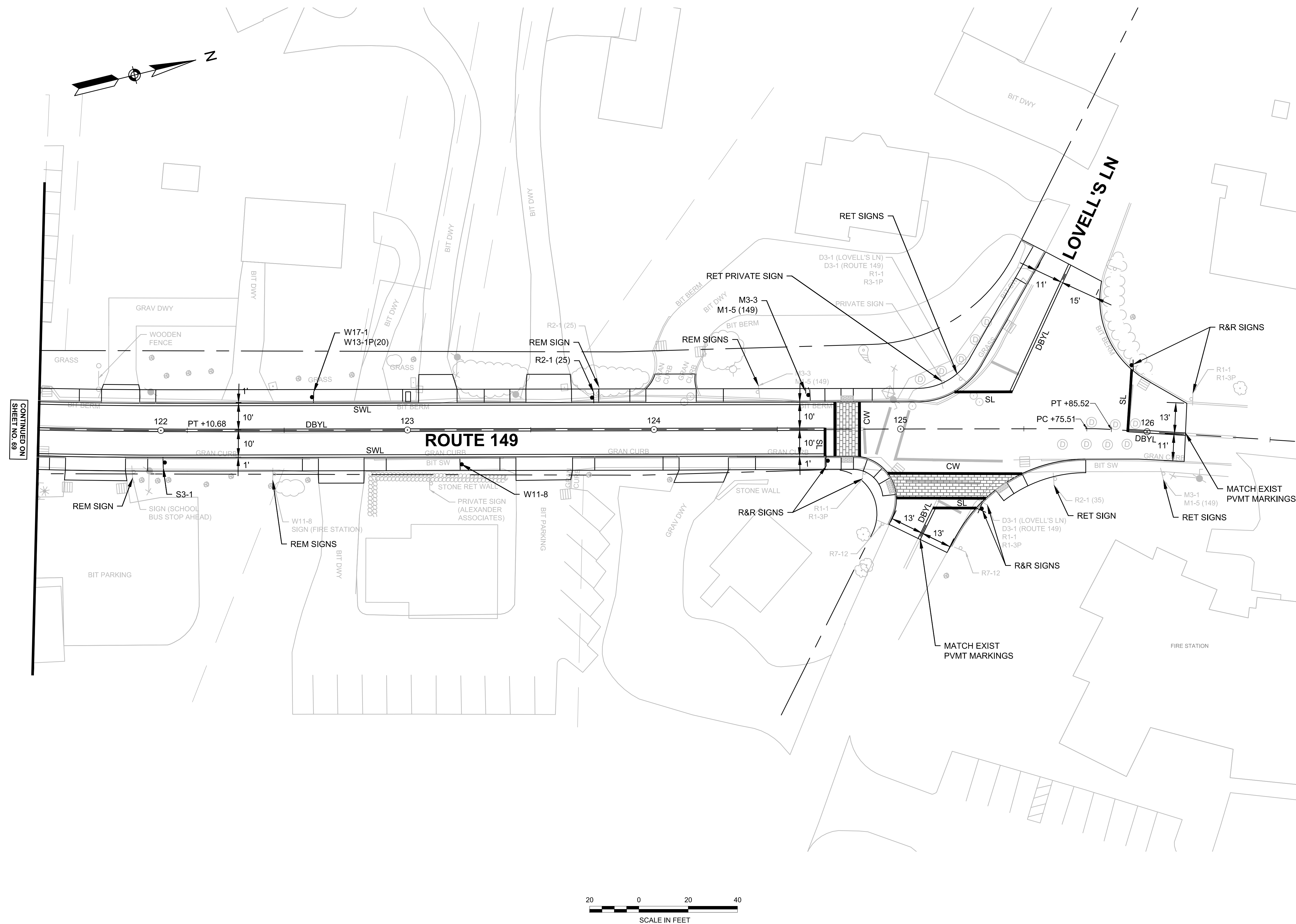

CONTINUED ON
SHEET NO. 69

BARNSTABLE
MARSTONS MILLS VILLAGE CENTER IMPROVEMENTS

SHEET NO.	TOTAL SHEETS
71	109

TRAFFIC SIGNS AND PAVEMENT MARKING PLAN
SHEET 6 OF 8

REV #	DATE
1	3/13/19

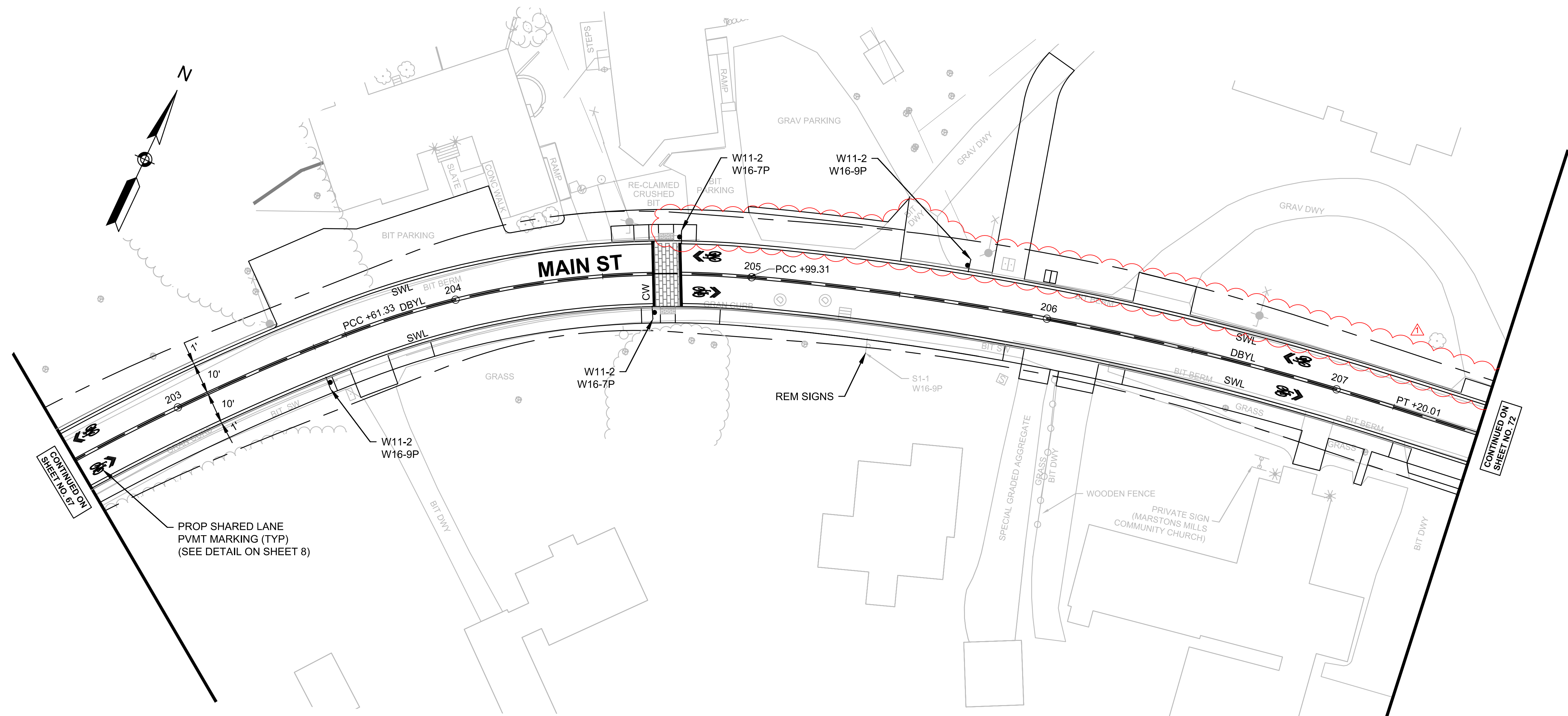

CONTINUED ON
SHEET NO. 87

PROP SHARED LANE
PVMT MARKING (TYP)
(SEE DETAIL ON SHEET 8)

CONTINUED ON
SHEET NO. 72



BARNSTABLE
MARSTONS MILLS VILLAGE CENTER IMPROVEMENTS

SHEET NO.	TOTAL SHEETS
72	109

TRAFFIC SIGNS AND PAVEMENT MARKING PLAN
SHEET 7 OF 8

REV #	DATE
1	3/13/19

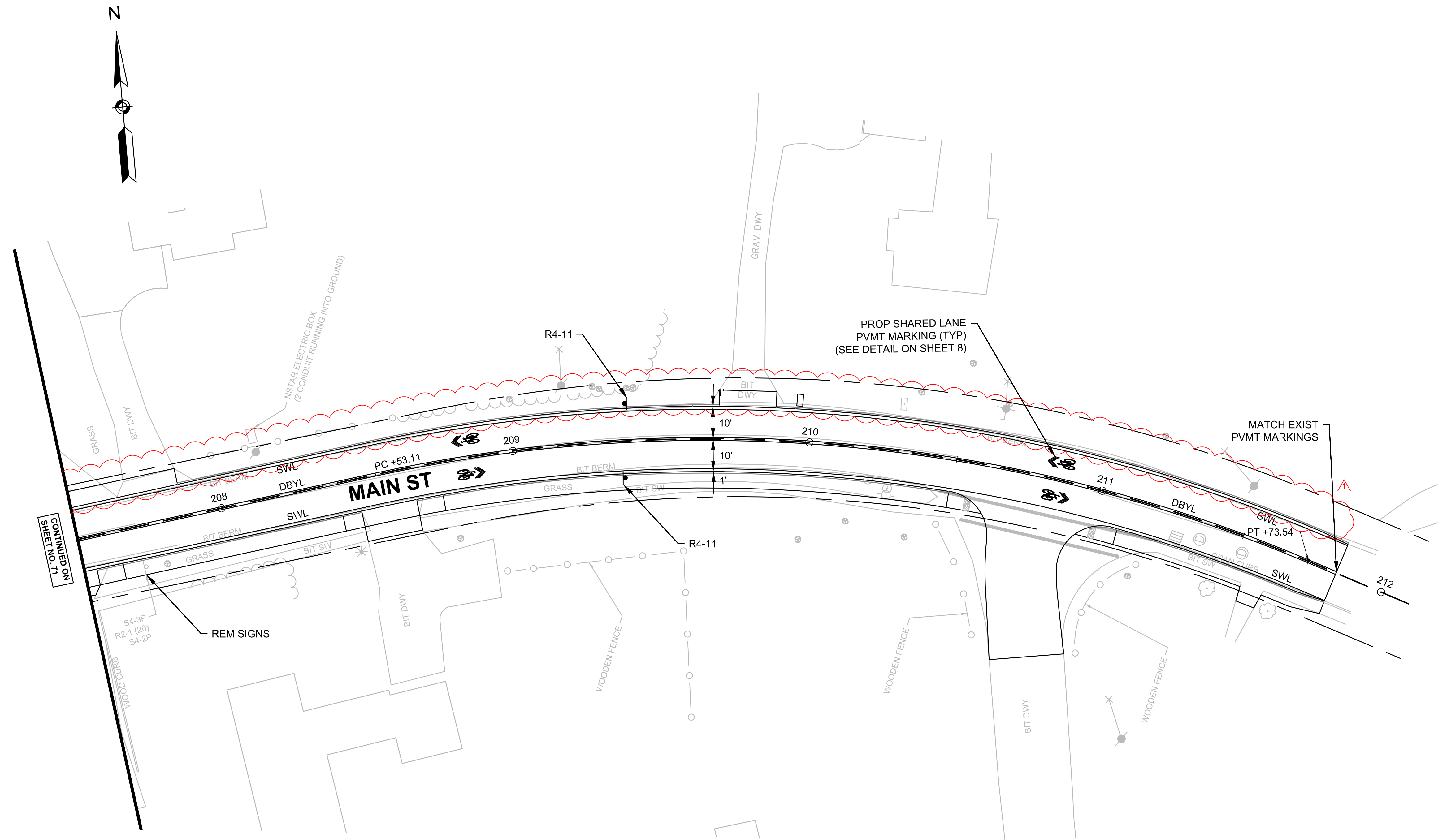

CONTINUED ON
SHEET NO. 71

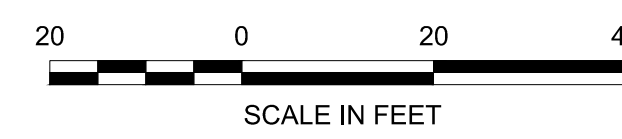

SHEET NO.	TOTAL SHEETS
73	109

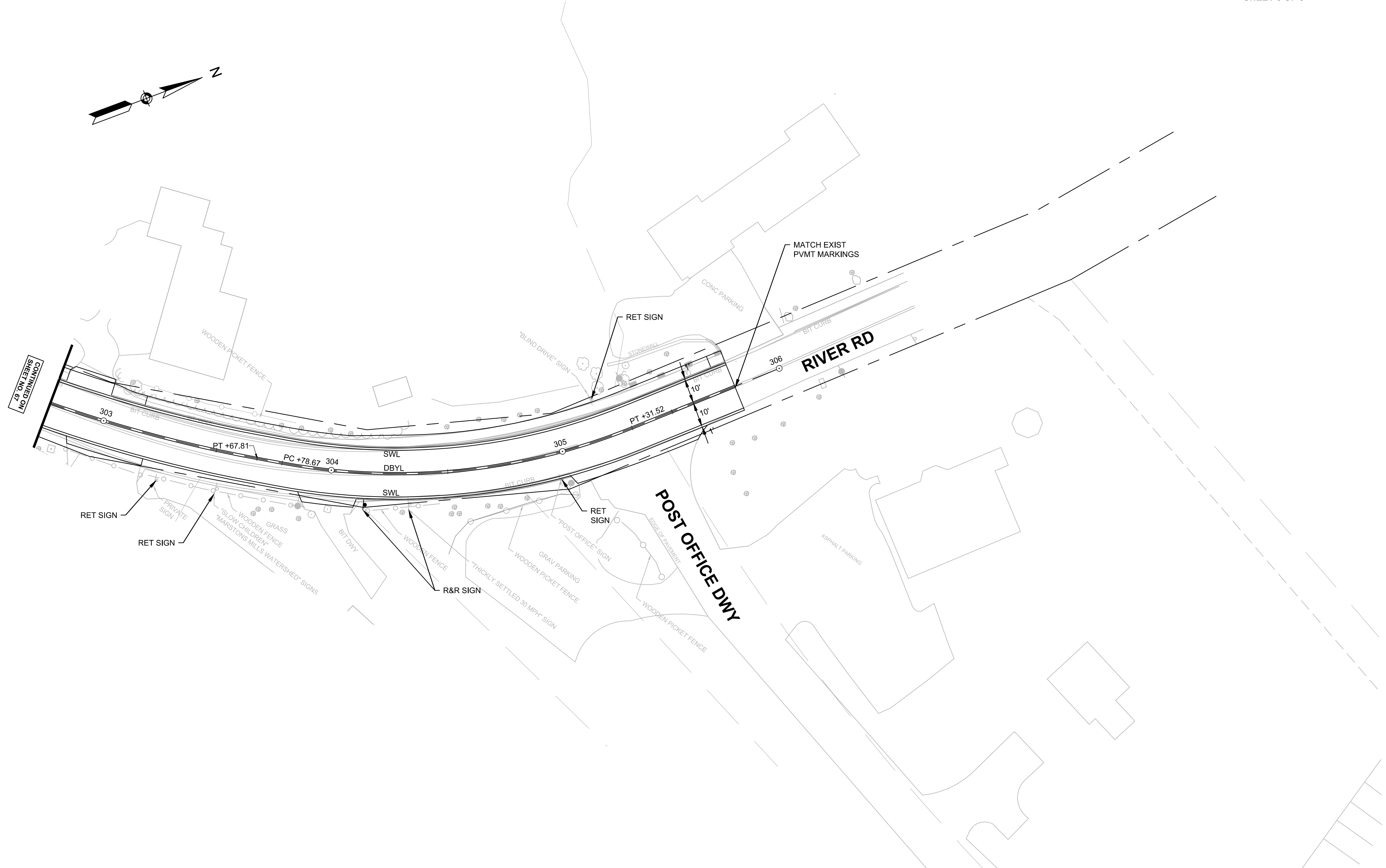
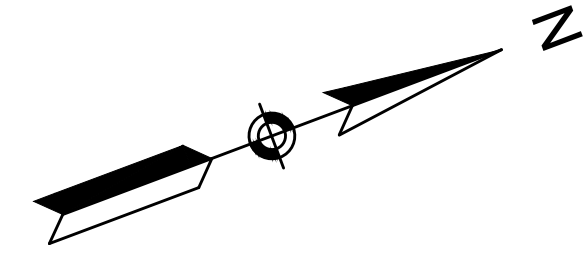











CONTINUED ON
SHEET NO. 87







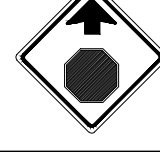
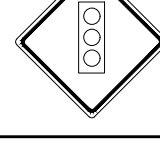

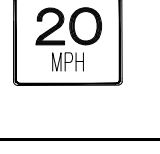
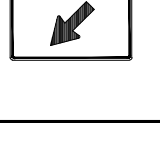



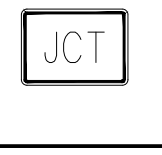
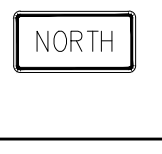

SHEET NO.	TOTAL SHEETS
74	109

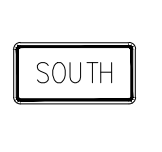
TRAFFIC SIGN SUMMARY

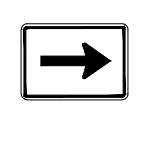
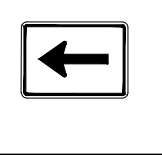
TRAFFIC SIGN SUMMARY

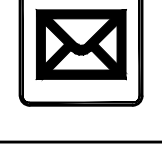
IDENTIFICATION NUMBER	SIZE OF SIGN		TEXT	TEXT DIMENSIONS (INCHES)			NUMBER OF SIGNS REQUIRED	COLOR			POST SIZE AND NUMBER REQUIRED	UNIT AREA (S.F.)	AREA IN SQUARE FEET
	WIDTH	HEIGHT		LETTER HEIGHT	VERTICAL SPACING	ARROW RTE. MKR.		BACK-GROUND	LEGEND	BORDER			
R1-1	30"	30"		SEE 2009 MUTCD			3	SEE 2009 MUTCD			P5-1 3-REQ	6.25	18.75
R1-5	36"	36"					5				P5-1 5-REQ	9.00	45.00
R2-1	24"	30"					2				P5-1 2-REQ	5.00	10.00
R3-1	24"	24"					1				1-MOUNT W/ R1-1	4.00	4.00
R4-1	24"	30"					1				P5-1 1-REQ	5.00	5.00
R4-11	30"	30"					5				P5-1 5-REQ	6.25	31.25
R7-8	12"	18"					1				P5-1 1-REQ	1.50	1.50
R7-8P	12"	6"					1				1-MOUNT W/ R7-8	0.50	0.50
W3-1	30"	30"					2				P5-1 2-REQ	6.25	12.50
W3-3	30"	30"					1				P5-1 1-REQ	6.25	6.25
W11-2	30"	30"					15				P5-1 15-REQ	6.25	93.75
W11-8	30"	30"					1				P5-1 1-REQ	6.25	6.25
W13-1P	18"	18"					6				6-MOUNT W/ W17-1	2.25	13.50
W16-7P	24"	12"					11				11-MOUNT W/ W11-2	2.00	22.00

IDENTIFICATION NUMBER	SIZE OF SIGN		TEXT	TEXT DIMENSIONS (INCHES)			NUMBER OF SIGNS REQUIRED	COLOR			POST SIZE AND NUMBER REQUIRED	UNIT AREA (S.F.)	AREA IN SQUARE FEET
	WIDTH	HEIGHT		LETTER HEIGHT	VERTICAL SPACING	ARROW RTE. MKR.		BACK-GROUND	LEGEND	BORDER			
W16-9P	24"	12"		SEE 2009 MUTCD			4	SEE 2009 MUTCD			4-MOUNT W/ W11-2	2.00	8.00
W17-1	30"	30"					6				P5-1 6-REQ	6.25	37.50
M1-5	24"	24"					3				P5-2 2-REQ P5-1 1-REQ	4.00	12.00
M1-5	30"	24"					4				P5-1 4-REQ	5.00	20.00
M2-1	21"	15"					1				1-MOUNT W/ M1-5 (28)	2.19	2.19
M3-1	24"	12"					3				3-MOUNT W/ M1-5 (149)	2.00	6.00
M3-2	24"	12"					1				1-MOUNT W/ M1-5 (28)	2.00	2.00
M3-3	24"	12"					1				1-MOUNT W/ M1-5 (149)	2.00	2.00
M3-4	24"	12"					1				1-MOUNT W/ M1-5 (28)	2.00	2.00
M6-1R	21"	15"					1				1-MOUNT W/ M1-5 (28)	2.19	2.19
M6-1L	21"	15"					4				2-MOUNT W/ M1-5 (28) 2-MOUNT W/ RS-026	2.19	8.76
S3-1	36"	36"					1				P5-1 1-REQ	9.00	9.00
RS-026	24"	24"					2				P5-1 2-REQ	4.00	8.00
RS-026P	24"	12"					2				2-MOUNT W/ RS-026	2.00	4.00

TOTAL: 393.89 SF

SHEET NO.	TOTAL SHEETS
75	109

TEMPORARY TRAFFIC CONTROL PLAN

12674 - TEMPORARY TRAFFIC CONTROL DWG 19-Oct-2018

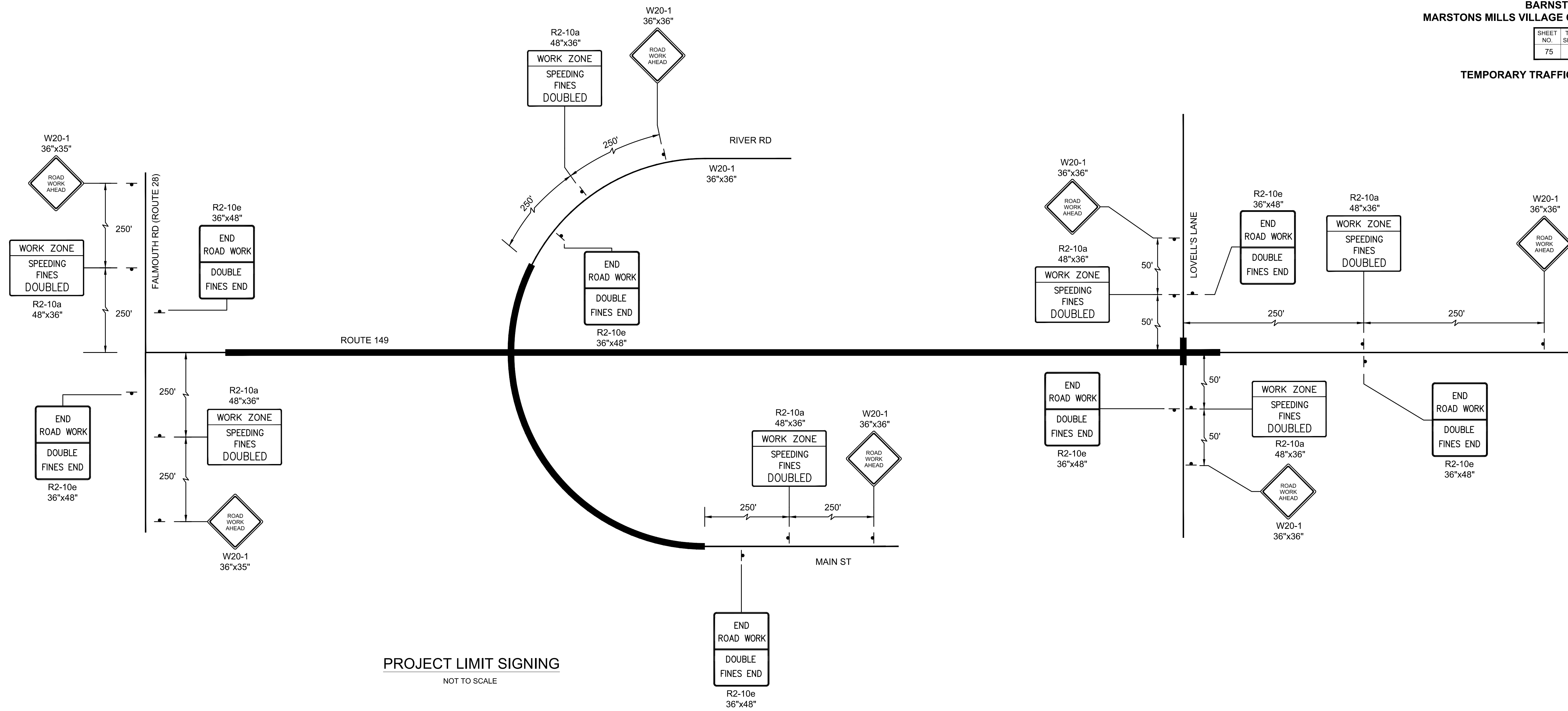

PROJECT LIMIT SIGNING
NOT TO SCALE

VARIABLE MESSAGE SIGN (VMS)
(REFER TO SHEET 76 FOR LOCATIONS)

VARIABLE MESSAGE SIGN (VMS) MESSAGES



NOTES:

- ALL TRAFFIC CONTROL DEVICES AND WORK ZONE SET-UPS ARE TO BE IN ACCORDANCE WITH MASSDOT AND MUTCD STANDARDS.
- DRUM SPACING SHALL BE 25 FEET ON ROUTE 149, MAIN STREET, AND RIVER ROAD.
- MINIMUM SPACING OF TRAFFIC DEVICES IN A TAPER (DRUMS AND CONES) IS EQUAL IN FEET TO THE SPEED LIMIT IN MILES PER HOUR.
- ALL SIGNS SHOWN SHALL BE MOUNTED ON SUITABLE TEMPORARY SUPPORTS SUCH THAT SIGNS ARE CLEARLY VISIBLE TO APPROACHING TRAFFIC.
- MAINTAIN ACCESS TO ALL DRIVEWAYS AND PEDESTRIAN SIDEWALKS AT ALL TIMES, UNLESS OTHERWISE NOTED.
- THE FIRST THREE PLASTIC DRUMS OF A TAPER MAY BE MOUNTED WITH TYPE A LIGHTS.
- THE ADVISORY SPEED LIMIT, IF REQUIRED, SHALL BE DETERMINED BY THE ENGINEER.
- DISTANCES ARE A GUIDE AND MAY BE ADJUSTED IN THE FIELD BY THE ENGINEER.
- MINIMUM TRAVEL LANE WIDTH IS TO BE 10 FEET, MEASURED FROM THE EDGE OF DRUMS OR MEDIAN BARRIER.

LEGEND:

- WORK AREA
- SIGN
- CHANNELIZING DEVICE
- FLASHING ARROW BOARD
- TYPE III BARRICADE
- FLAGGER
- ARROW PANEL SUPPORT TRAILER
- FLOW DIRECTION
- WORK ZONE

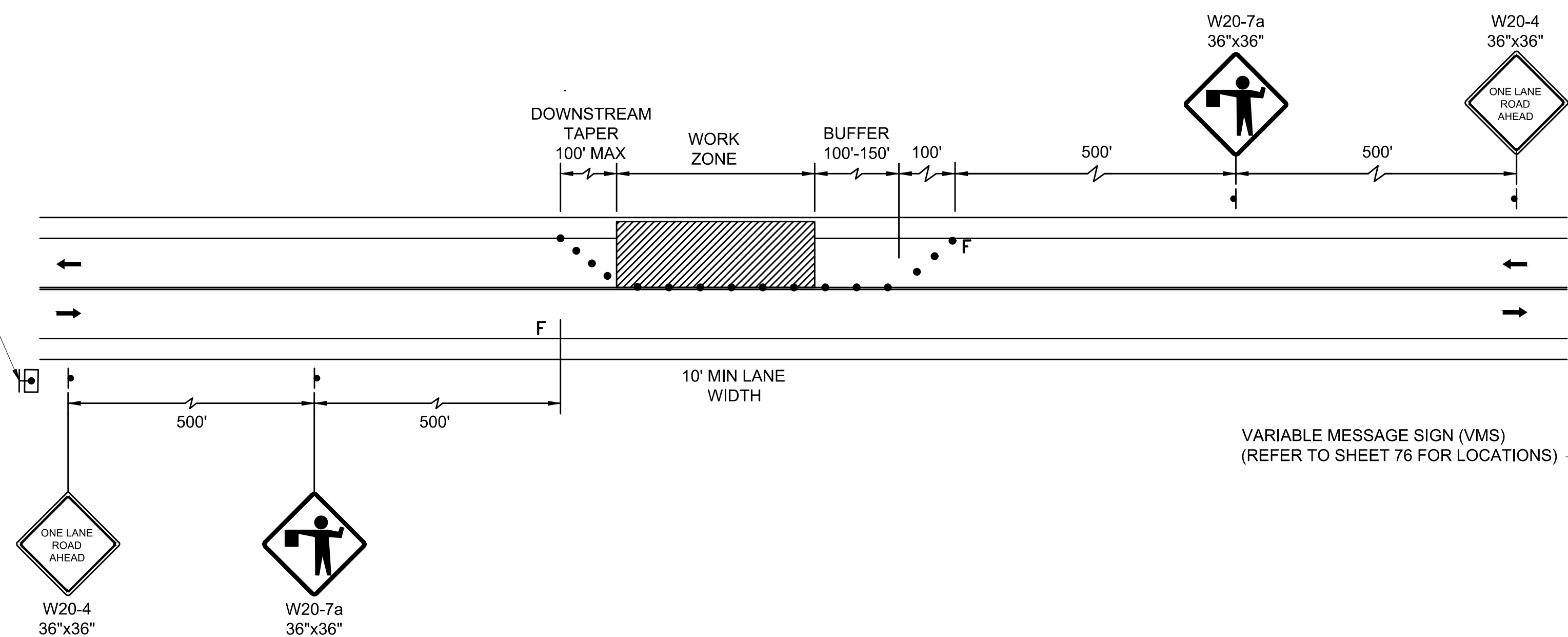

ONE LANE ALTERNATING TRAFFIC WITH FLAGGER
NOT TO SCALE

REV #	DATE
1	2/6/19

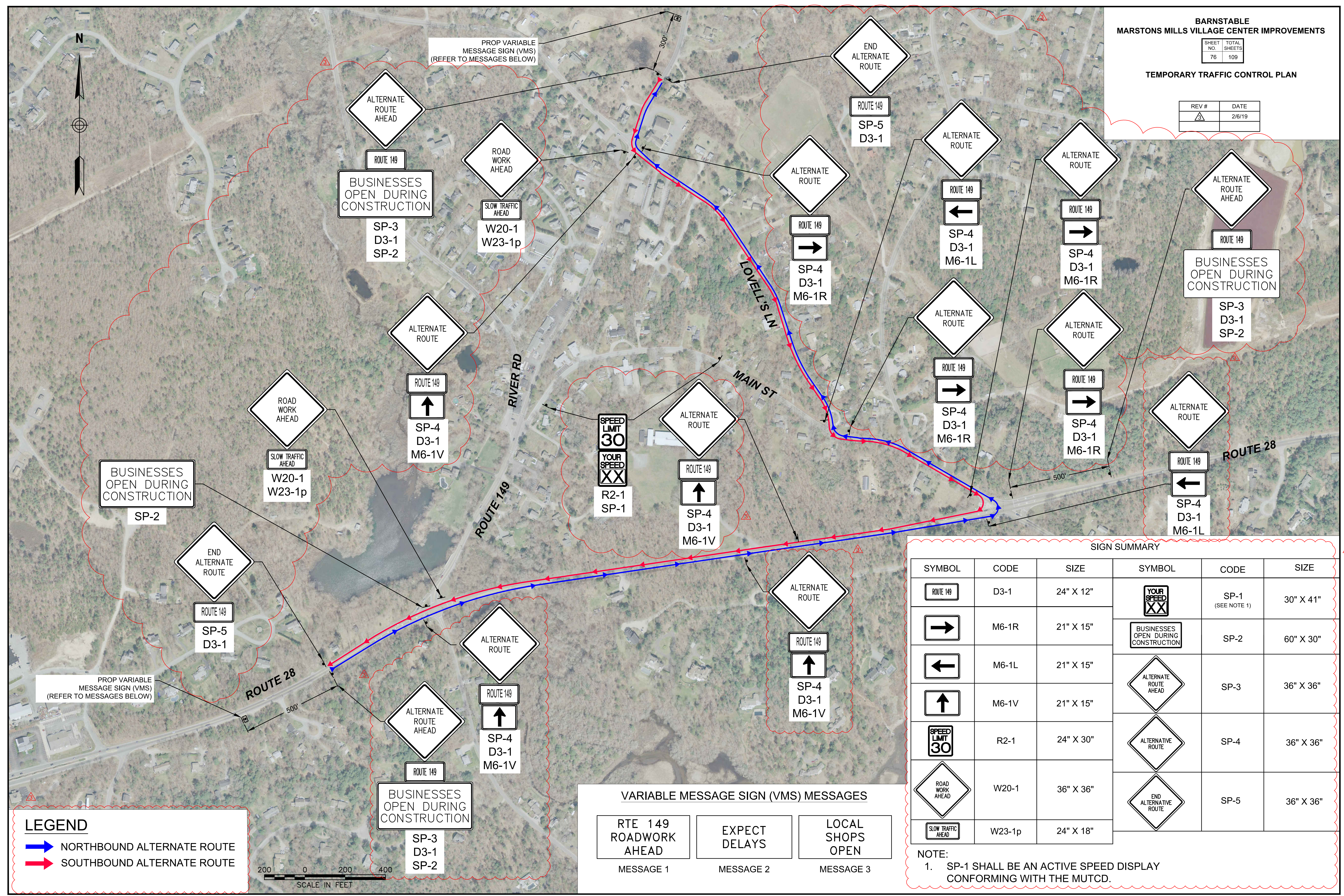

LEGEND

NORTHBOUND ALTERNATE ROUTE
 SOUTHBOUND ALTERNATE ROUTE

VARIABLE MESSAGE SIGN (VMS) MESSAGES

RTE 149 ROADWORK AHEAD	EXPECT DELAYS	LOCAL SHOPS OPEN
MESSAGE 1	MESSAGE 2	MESSAGE 3

SIGN SUMMARY

SYMBOL	CODE	SIZE	SYMBOL	CODE	SIZE
	D3-1	24" X 12"		SP-1 (SEE NOTE 1)	30" X 41"
	M6-1R	21" X 15"		SP-2	60" X 30"
	M6-1L	21" X 15"		SP-3	36" X 36"
	M6-1V	21" X 15"		SP-4	36" X 36"
	R2-1	24" X 30"		SP-5	36" X 36"
	W20-1	36" X 36"			
	W23-1p	24" X 18"			

NOTE:
 1. SP-1 SHALL BE AN ACTIVE SPEED DISPLAY CONFORMING WITH THE MUTCD.

BARNSTABLE
MARSTONS MILLS VILLAGE CENTER IMPROVEMENTS

SHEET NO.	TOTAL SHEETS
77	109

CROSS SECTIONS - SHEET 12674 - Cross Sections - 1 OF 33
ROUTE 149

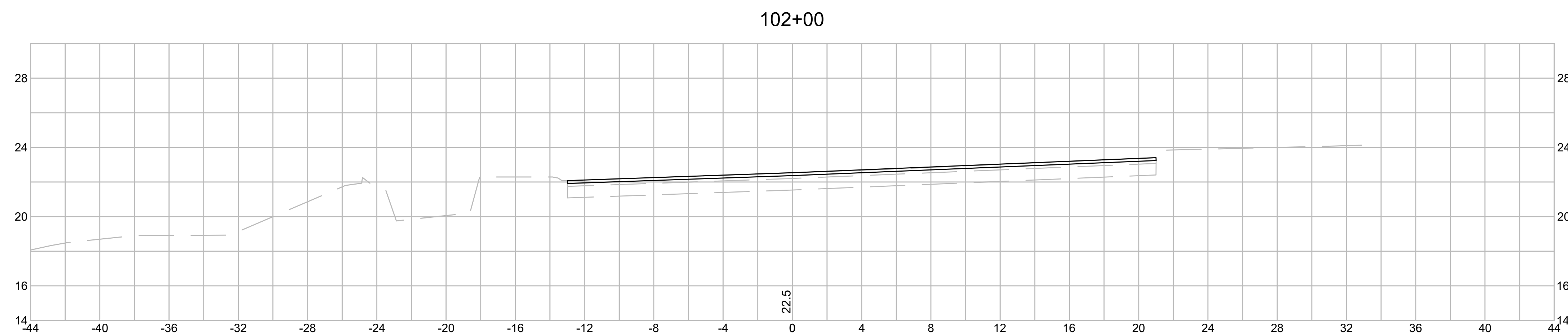
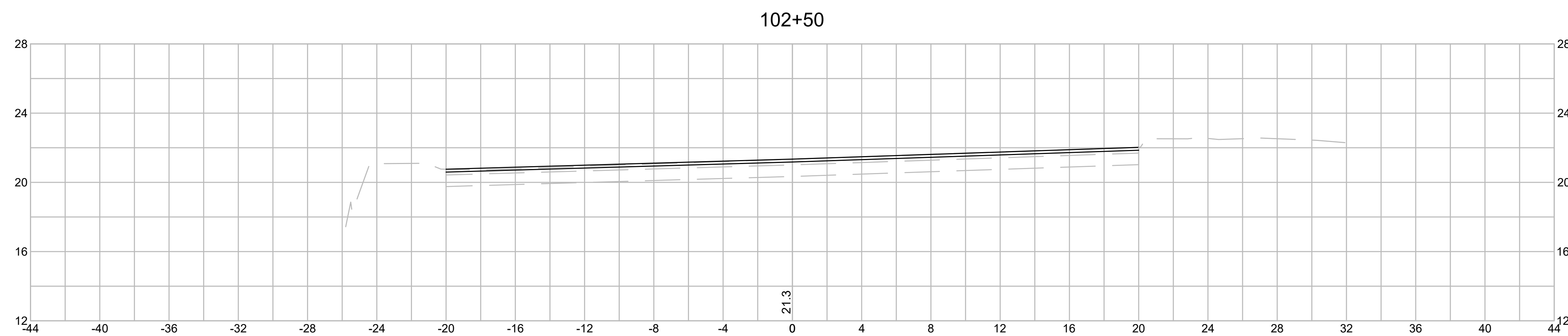
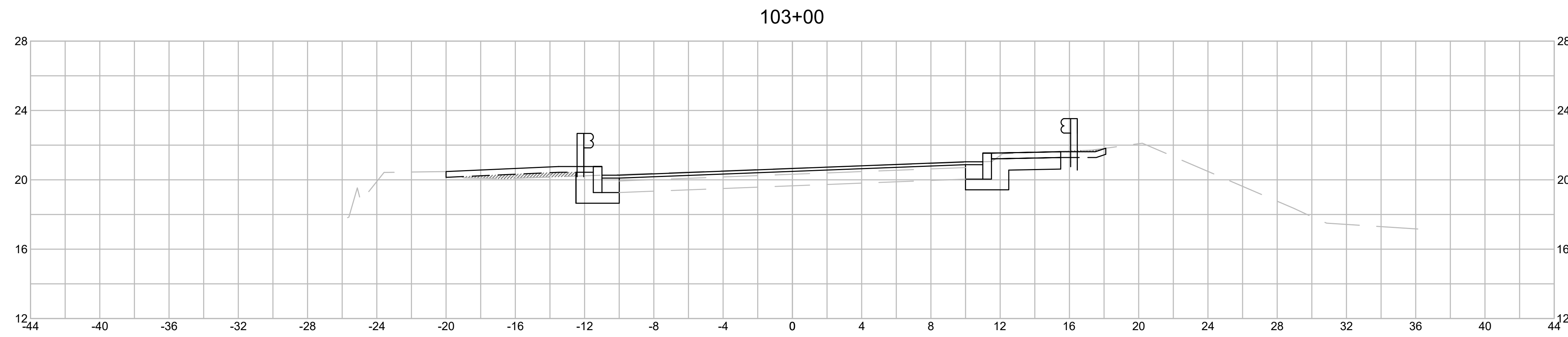

**BARNSTABLE
MARSTONS MILLS VILLAGE CENTER IMPROVEMENTS**

SHEET NO.	TOTAL SHEETS
78	109

**CROSS SECTIONS - SHEET 12674 - Cross Sections - 2 OF 33
ROUTE 149**

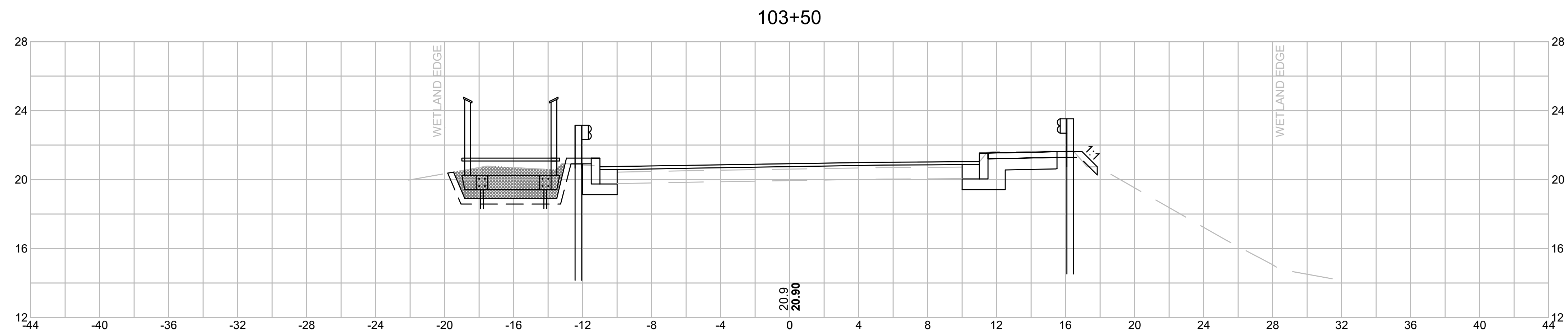
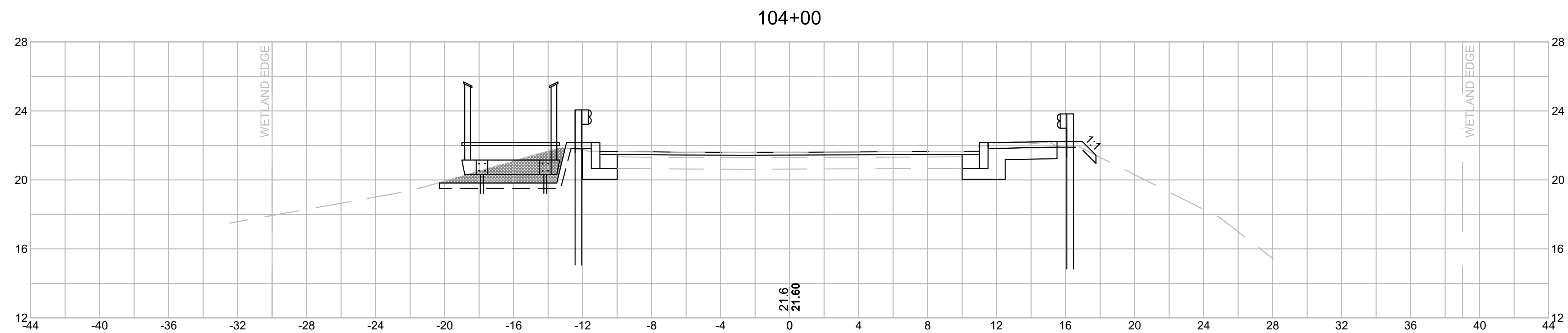
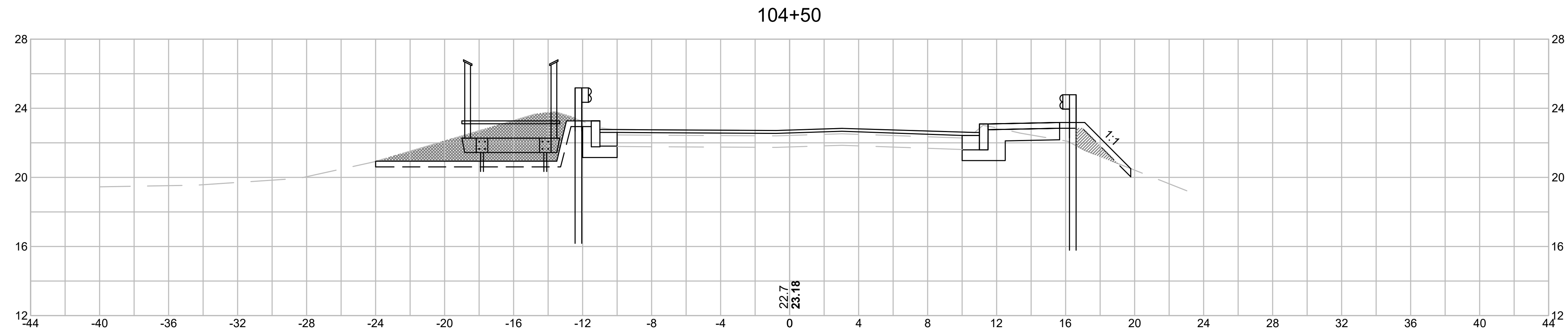

**BARNSTABLE
MARSTONS MILLS VILLAGE CENTER IMPROVEMENTS**

SHEET NO.	TOTAL SHEETS
79	109

**CROSS SECTIONS - SHEET 12674 - Cross Sections - 3 OF 33
ROUTE 149**

12674 - CROSS SECTIONS.DWG 17-Jul-2018

105+42

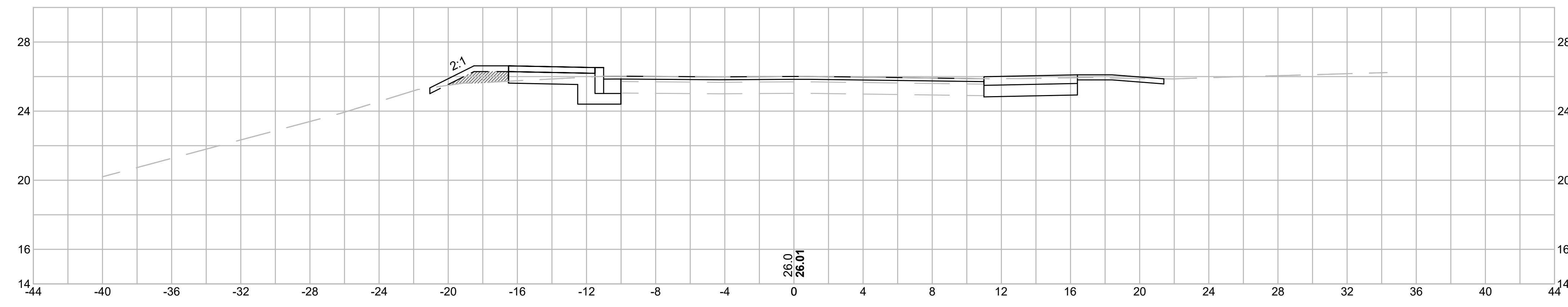

CUT: 0.0 SF
FILL: 2.0 SF

105+00

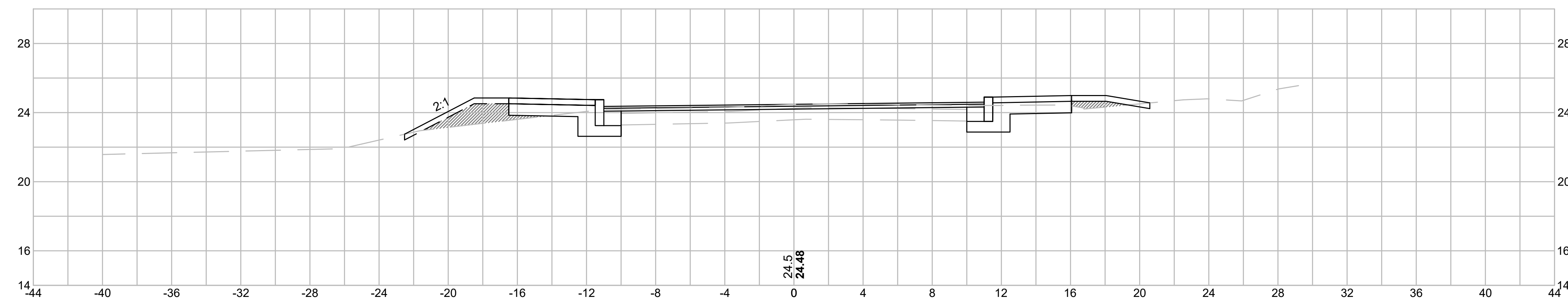

CUT: 0.0 SF
FILL: 5.0 SF

104+77

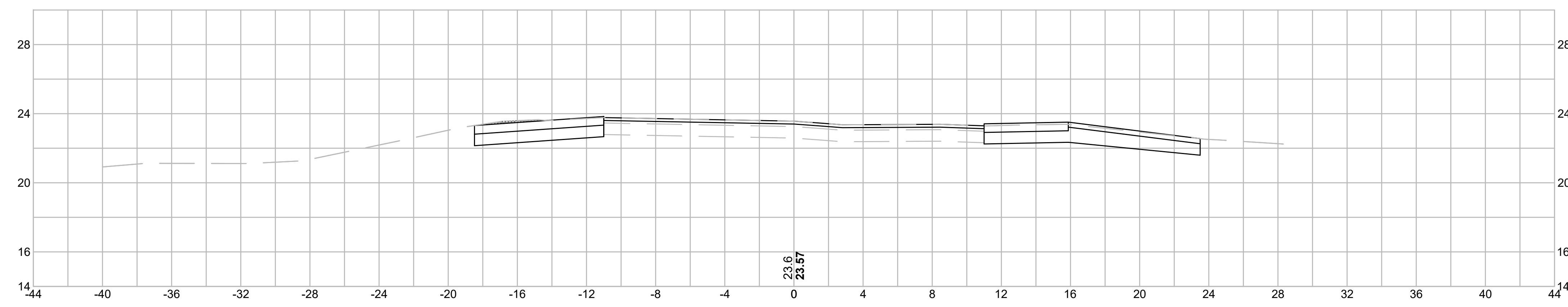

CUT: 0.5 SF
FILL: 0.0 SF

BARNSTABLE
MARSTONS MILLS VILLAGE CENTER IMPROVEMENTS

SHEET NO.	TOTAL SHEETS
80	109

CROSS SECTIONS - SHEET 12674 - Cross Sections - 4 OF 33
ROUTE 149

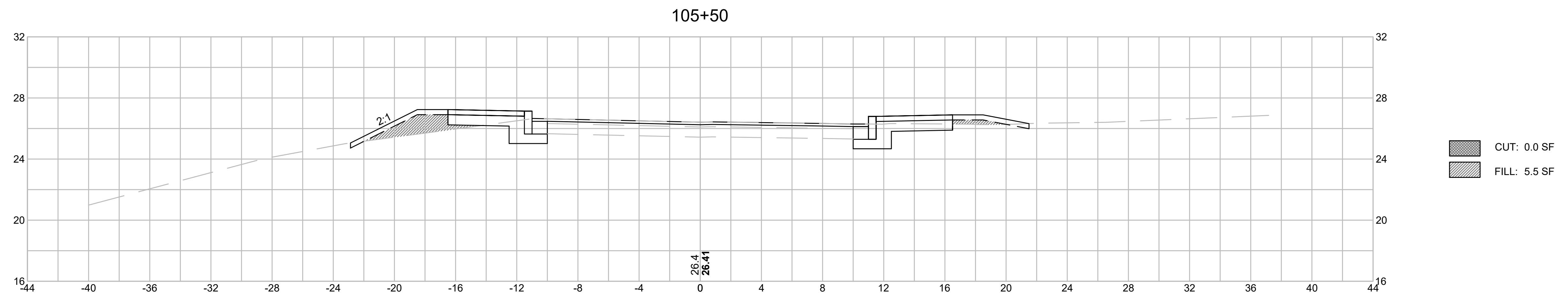
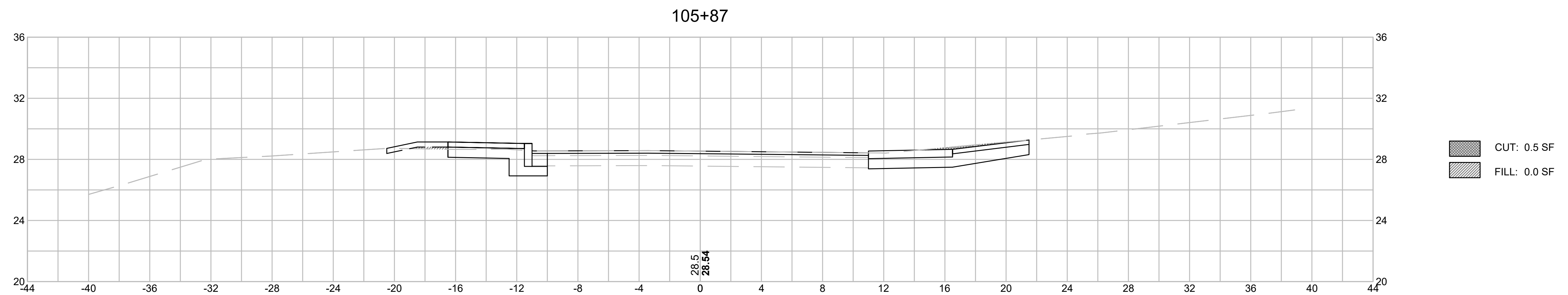
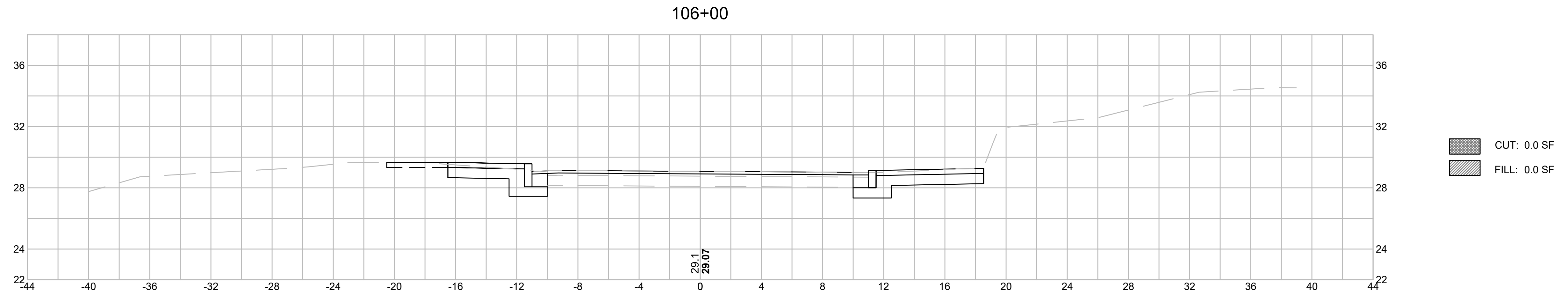

BARNSTABLE
MARSTONS MILLS VILLAGE CENTER IMPROVEMENTS

SHEET NO.	TOTAL SHEETS
81	109

CROSS SECTIONS - SHEET 12674 - Cross Sections - 5 OF 33
ROUTE 149

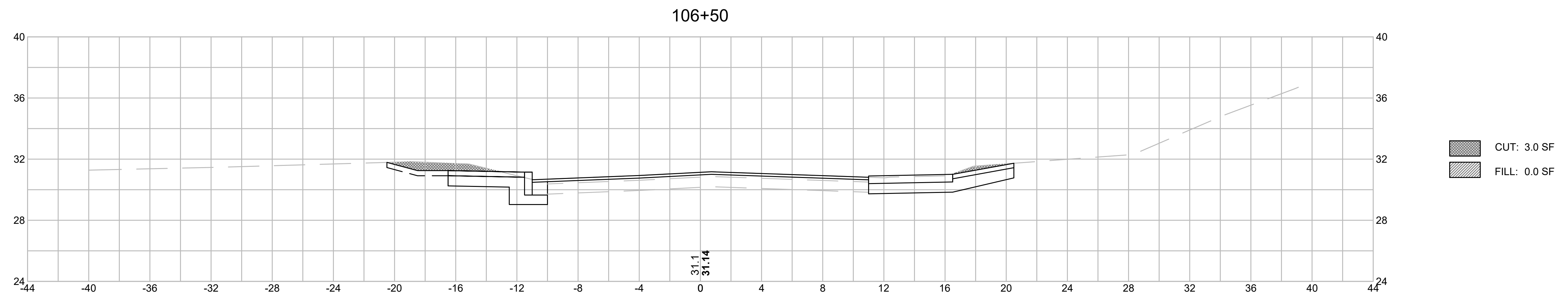
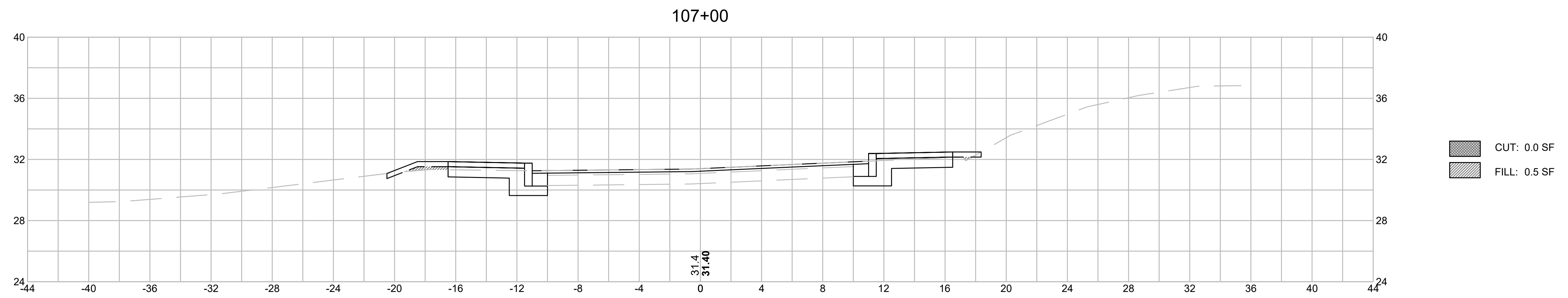

BARNSTABLE
MARSTONS MILLS VILLAGE CENTER IMPROVEMENTS

SHEET NO.	TOTAL SHEETS
82	109

CROSS SECTIONS - SHEET 12674 - Cross Sections - 6 OF 33
ROUTE 149

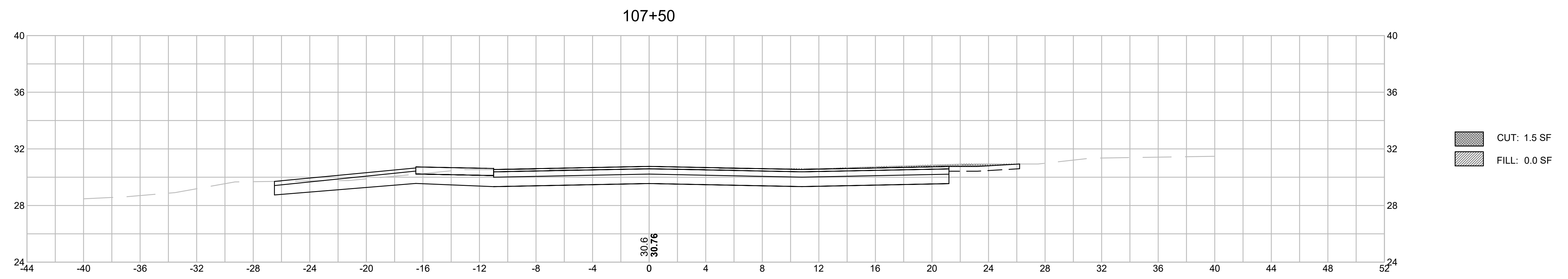
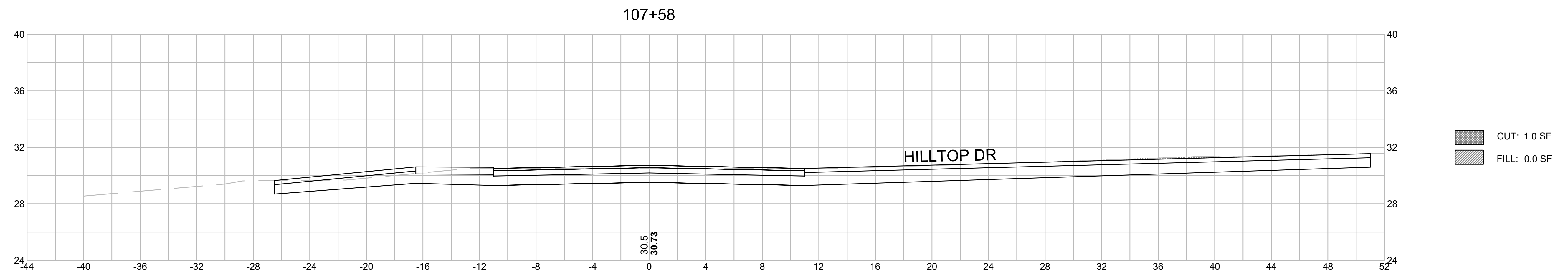
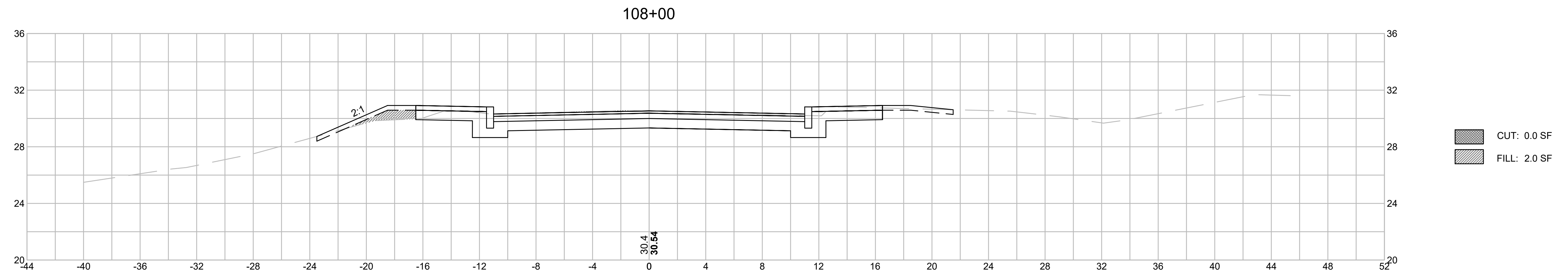

BARNSTABLE
MARSTONS MILLS VILLAGE CENTER IMPROVEMENTS

SHEET NO.	TOTAL SHEETS
83	109

CROSS SECTIONS - SHEET 12674 - Cross Sections - 7 OF 33
ROUTE 149

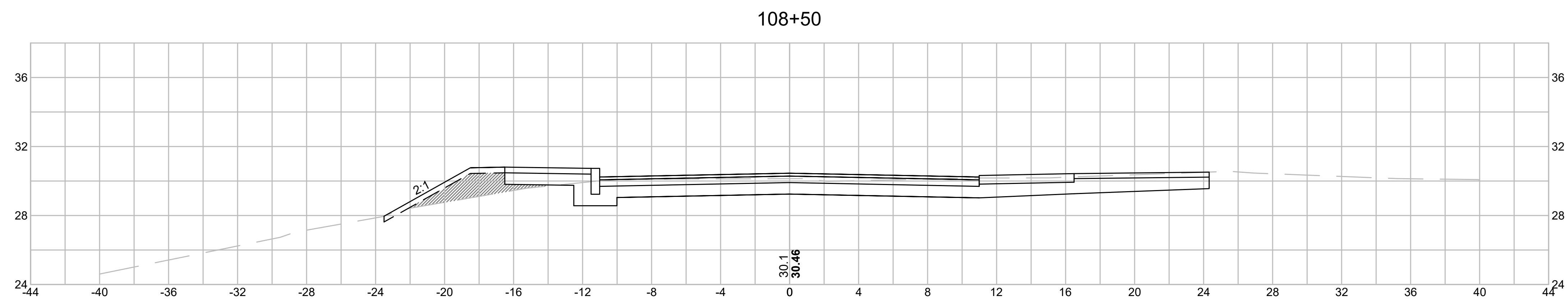
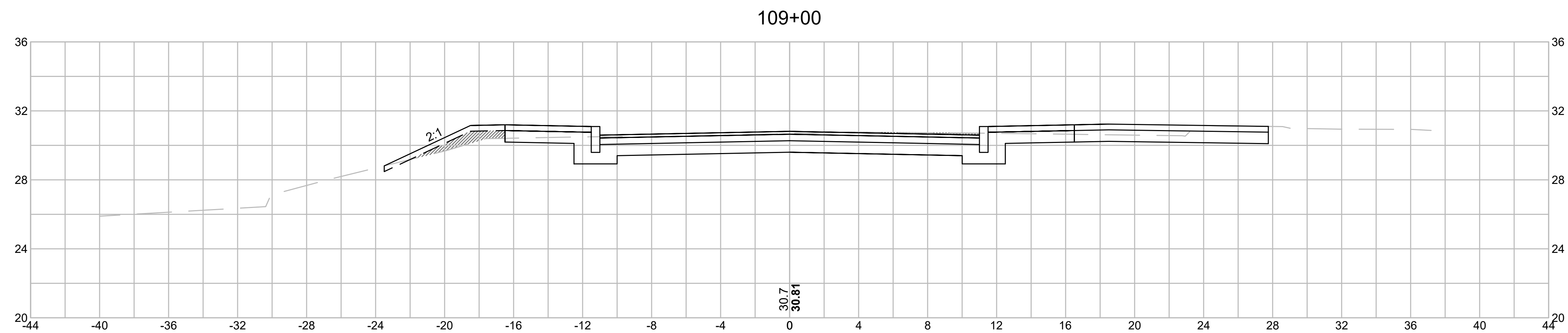
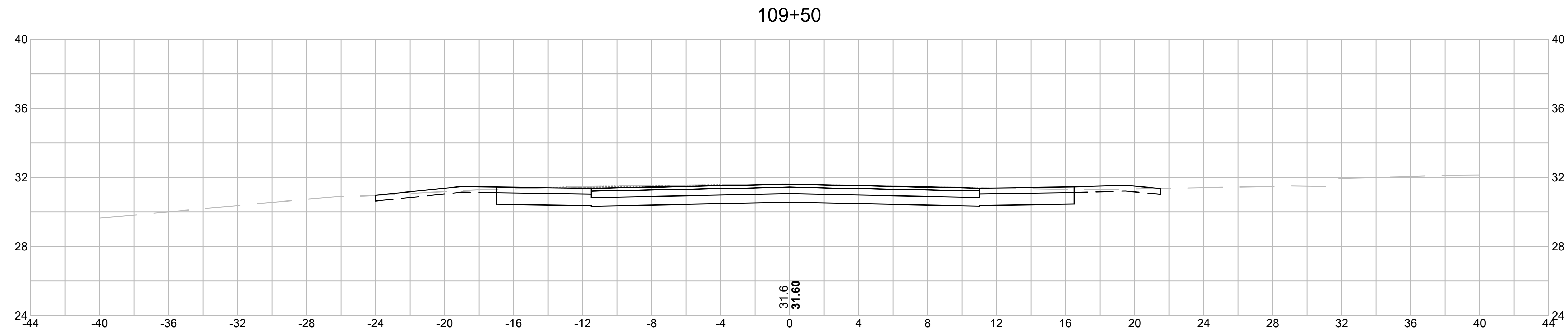

**BARNSTABLE
MARSTONS MILLS VILLAGE CENTER IMPROVEMENTS**

SHEET NO.	TOTAL SHEETS
84	109

**CROSS SECTIONS - SHEET 12674 - Cross Sections - 8 OF 33
ROUTE 149**

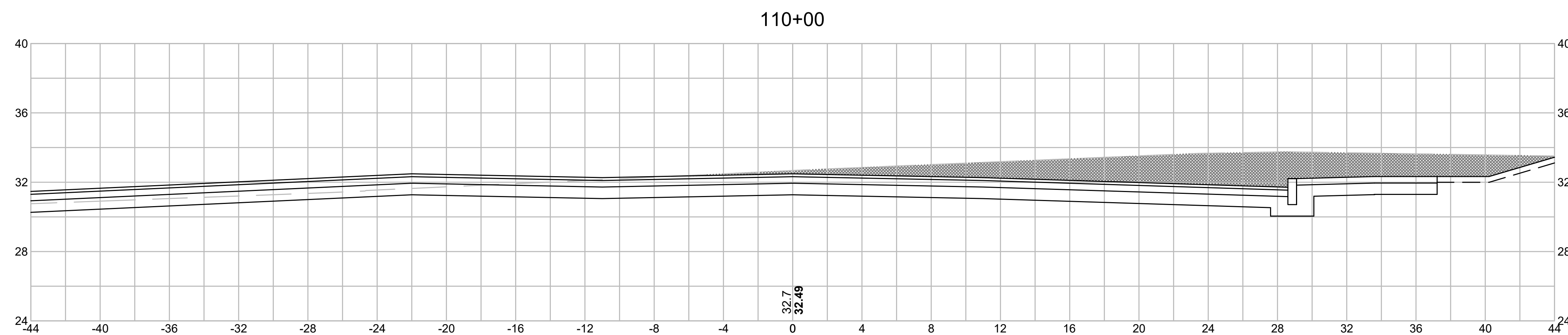
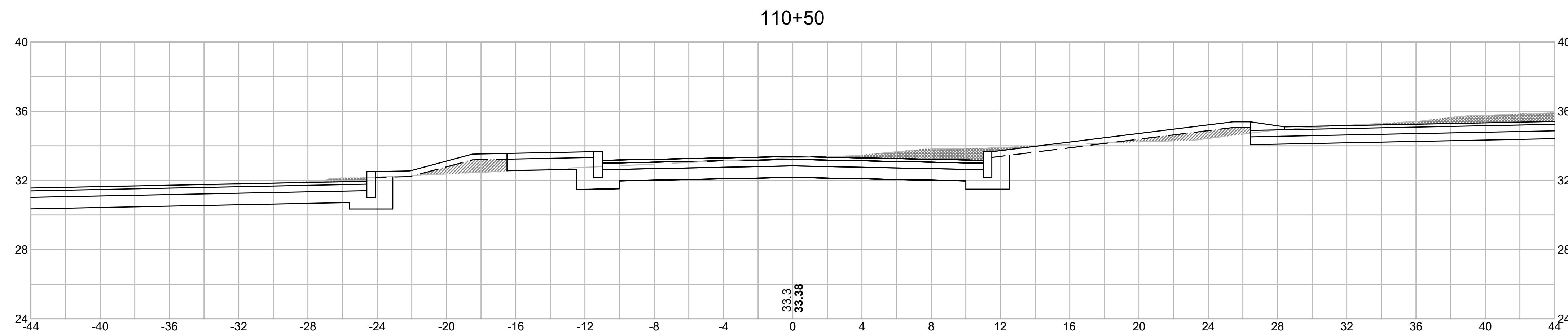
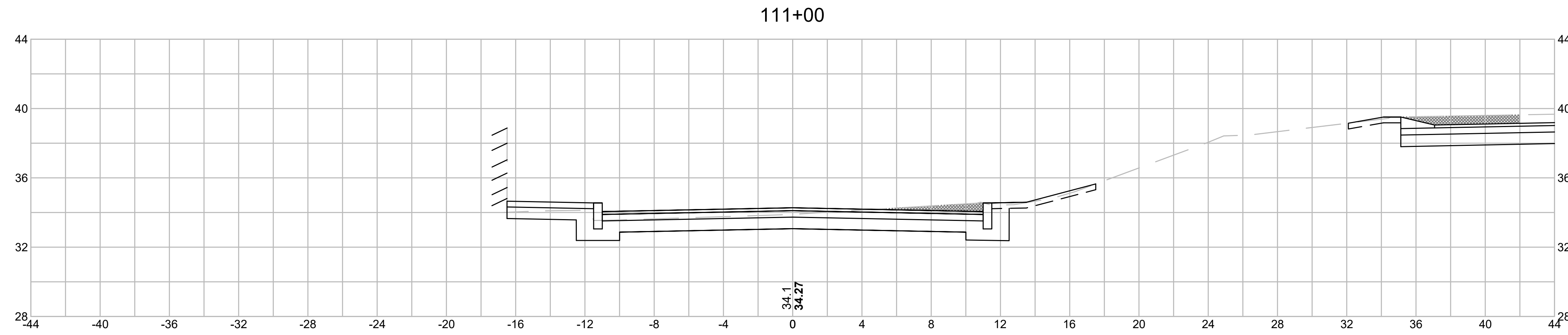

**BARNSTABLE
MARSTONS MILLS VILLAGE CENTER IMPROVEMENTS**

SHEET NO.	TOTAL SHEETS
85	109

**CROSS SECTIONS - SHEET 12674 - Cross Sections - 9 OF 33
ROUTE 149**

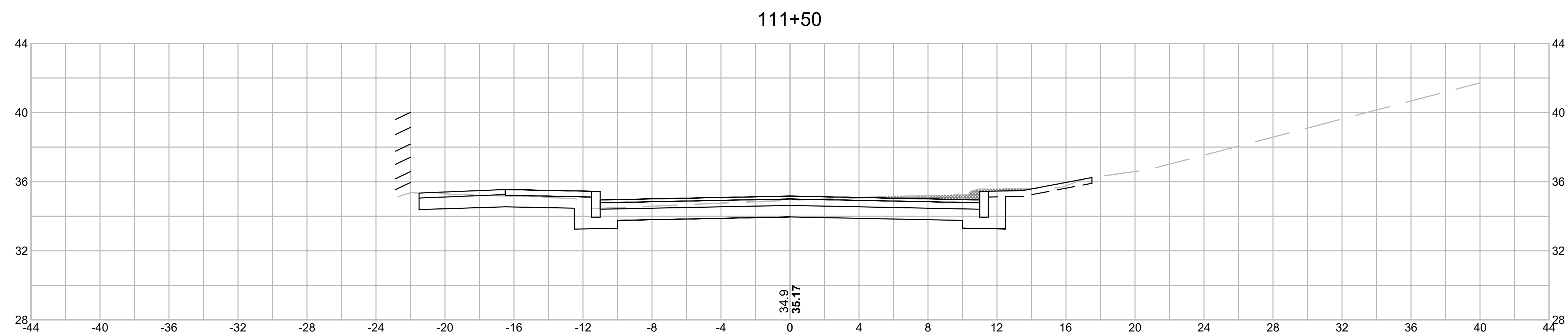
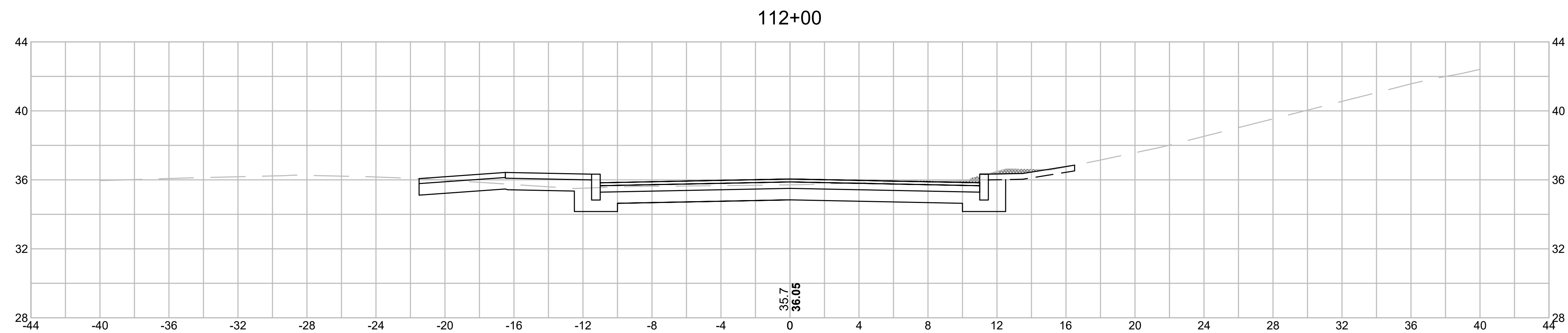
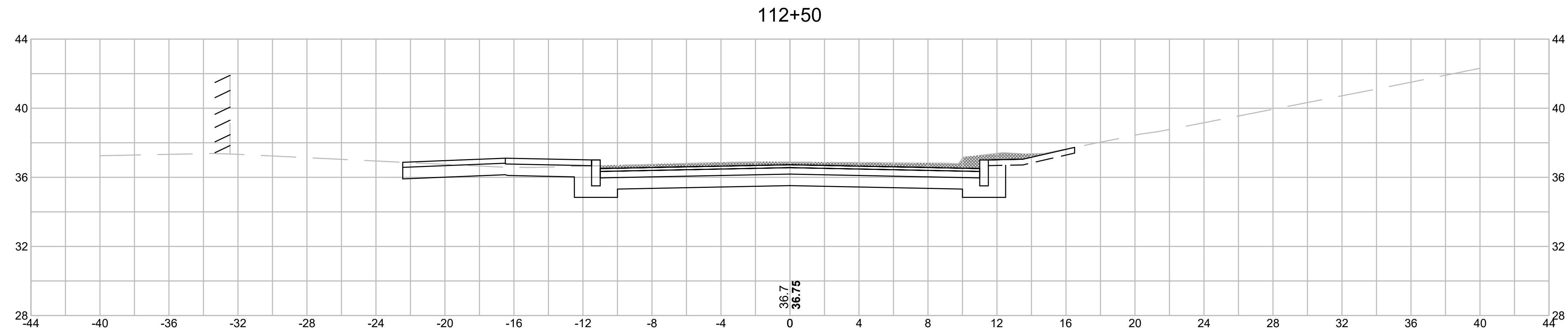

**BARNSTABLE
MARSTONS MILLS VILLAGE CENTER IMPROVEMENTS**

SHEET NO.	TOTAL SHEETS
86	

**CROSS SECTIONS - SHEET 12674 - Cross Sections - 10 OF 33
ROUTE 149**

12674 - CROSS SECTIONS.DWG 17-Jul-2018

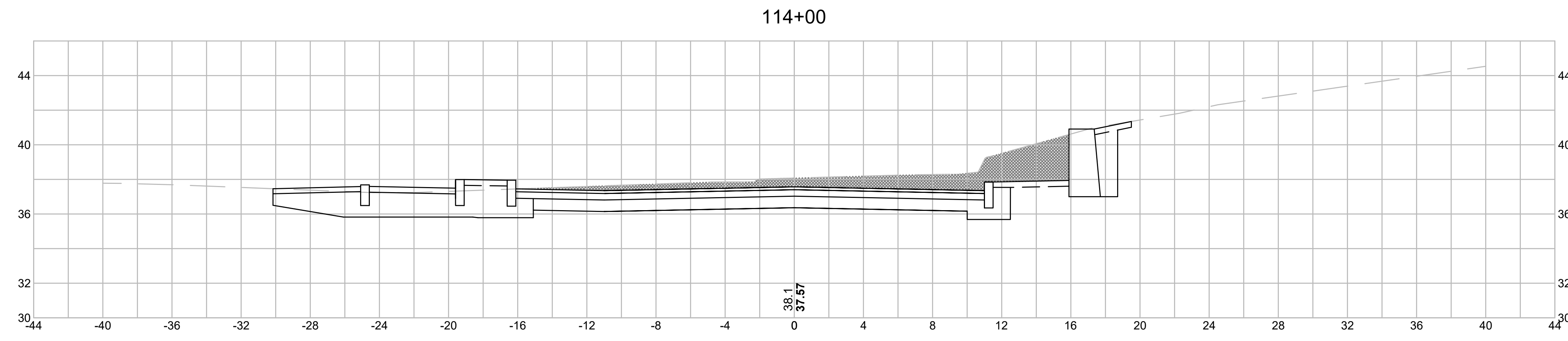

CUT: 23.0 SF
 FILL: 0.0 SF

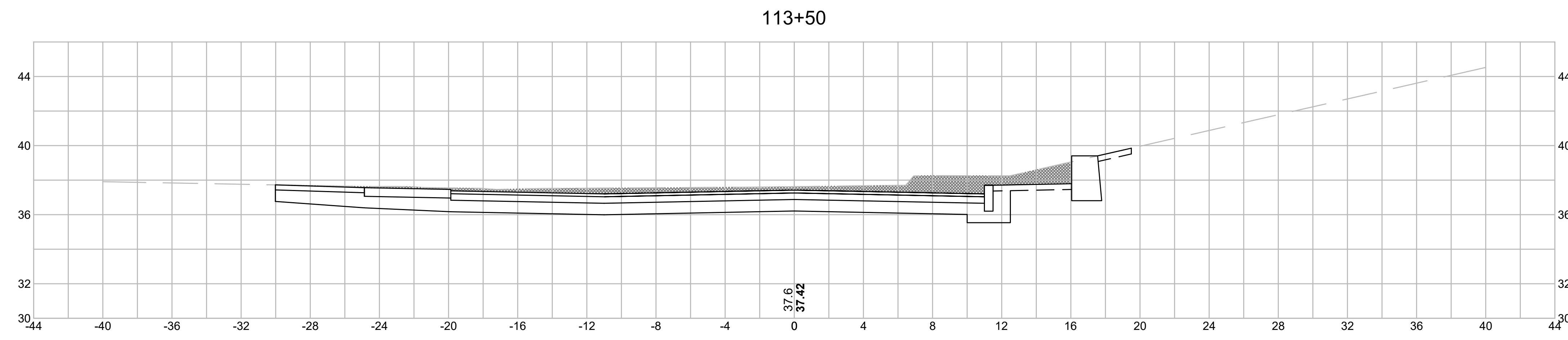

CUT: 16.0 SF
 FILL: 0.0 SF

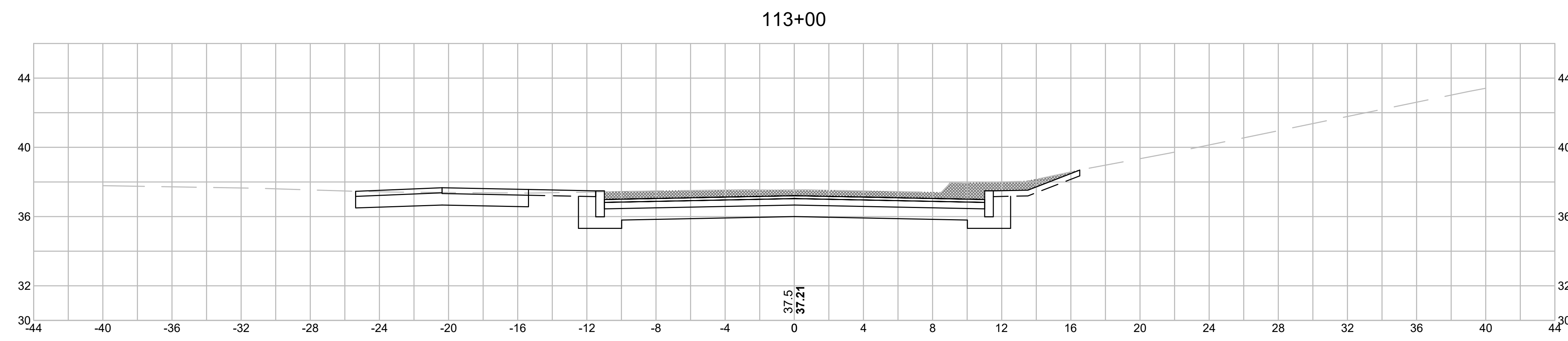

CUT: 12.0 SF
 FILL: 0.0 SF

BARNSTABLE
MARSTONS MILLS VILLAGE CENTER IMPROVEMENTS

SHEET NO.	TOTAL SHEETS
87	109

CROSS SECTIONS - SHEET 12674 - Cross Sections - 11 OF 33
ROUTE 149

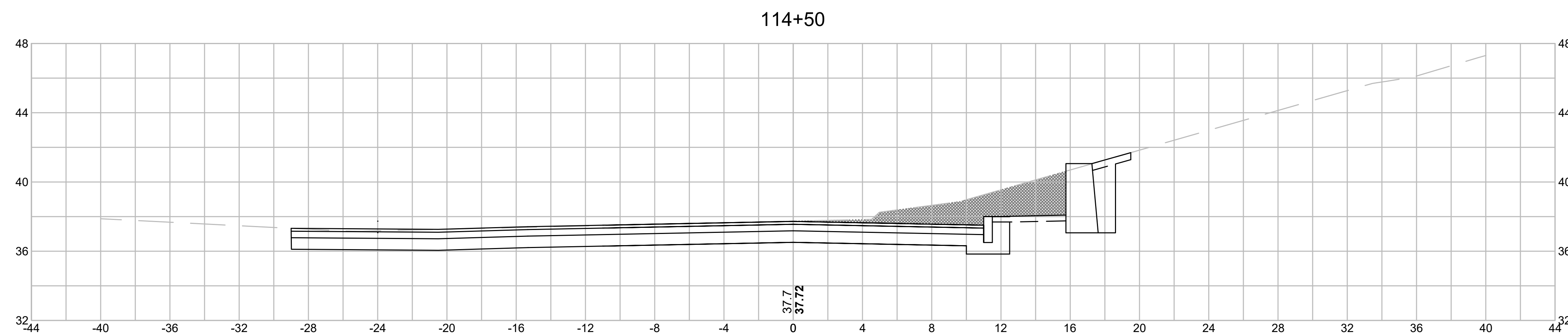
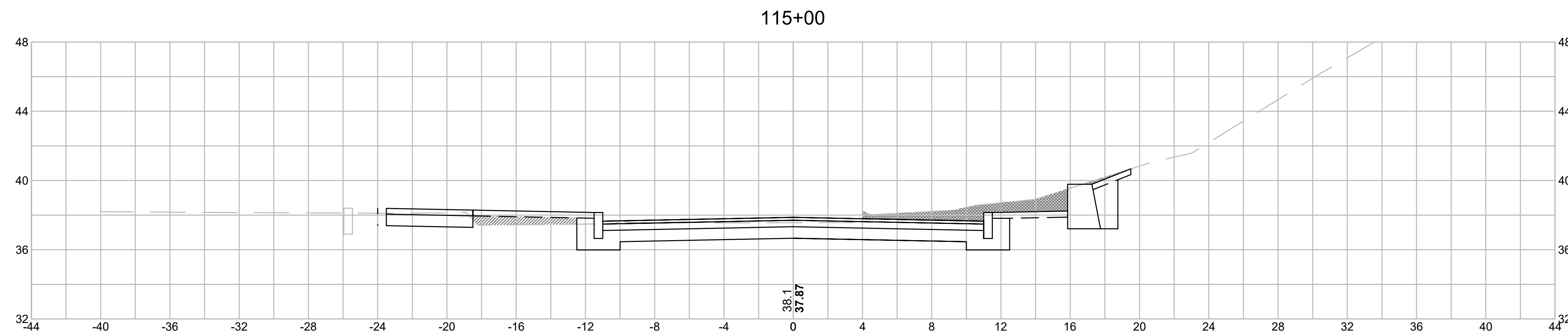
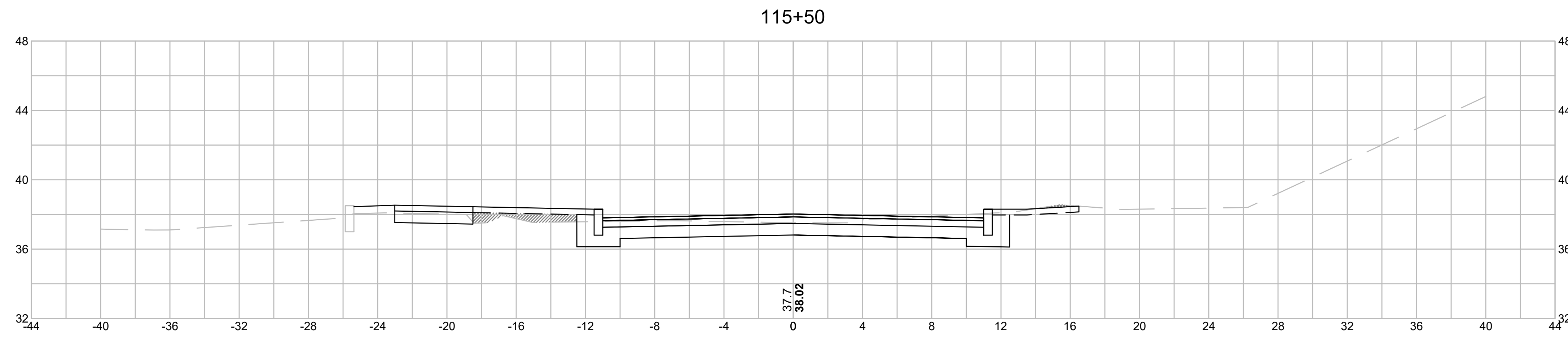

**BARNSTABLE
MARSTONS MILLS VILLAGE CENTER IMPROVEMENTS**

SHEET NO.	TOTAL SHEETS
88	109

**CROSS SECTIONS - SHEET 12674 - Cross Sections - 12 OF 33
ROUTE 149**

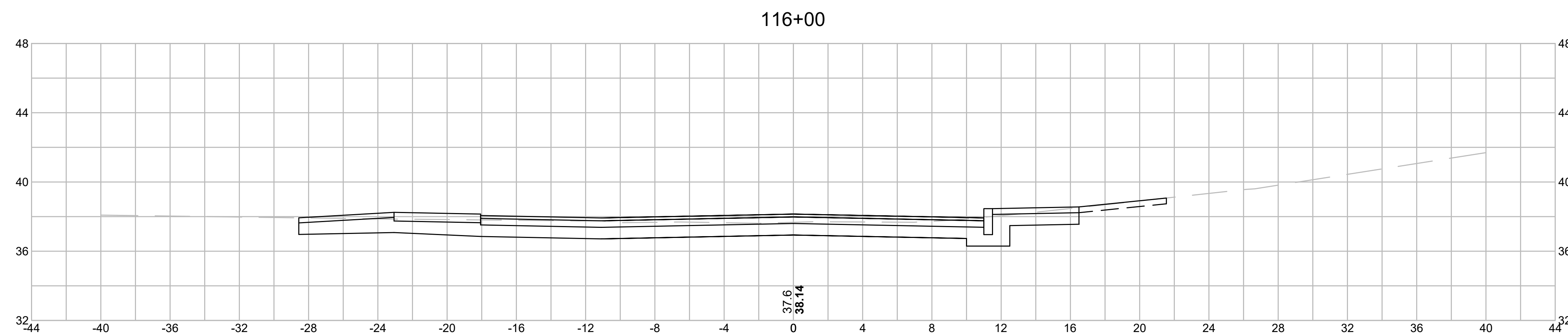
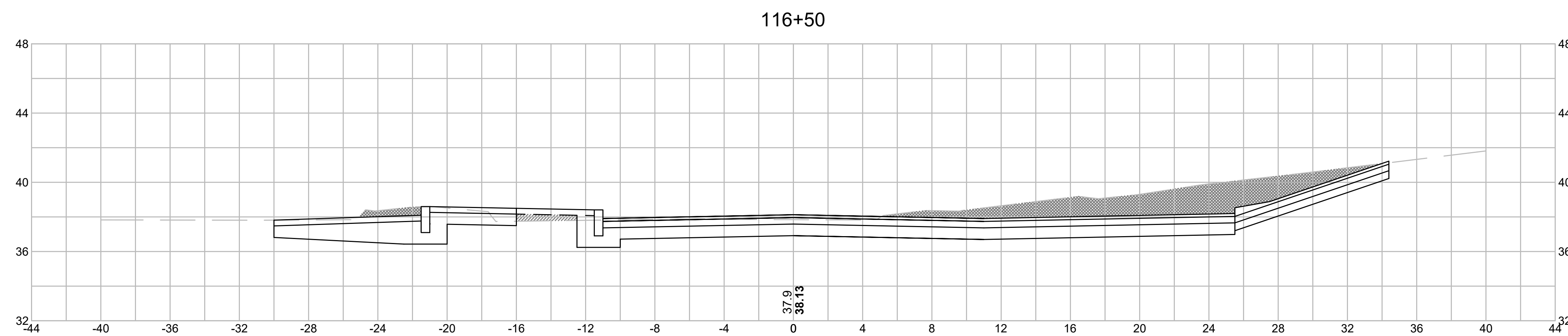
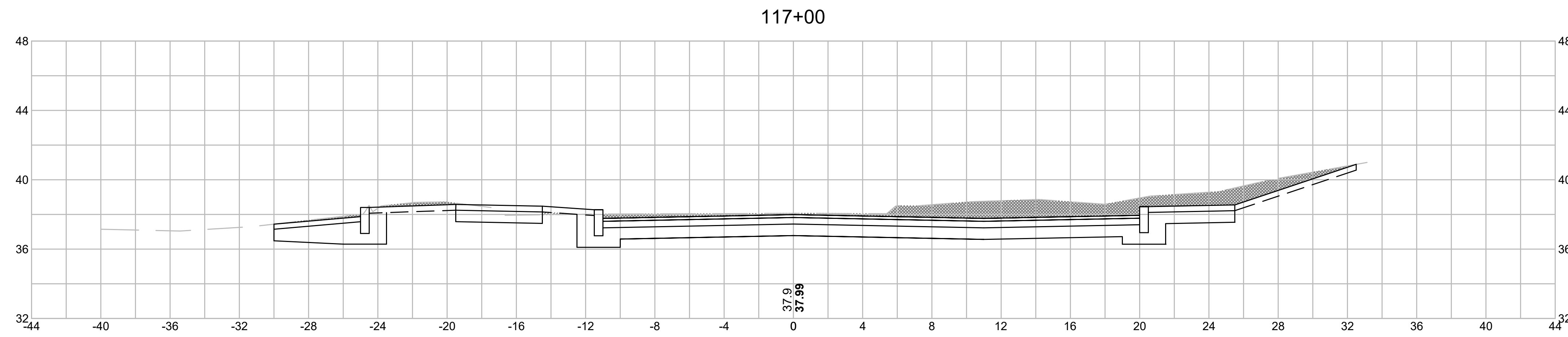

**BARNSTABLE
MARSTONS MILLS VILLAGE CENTER IMPROVEMENTS**

SHEET NO.	TOTAL SHEETS
89	109

**CROSS SECTIONS - SHEET 12674 - Cross Sections - 13 OF 33
ROUTE 149**

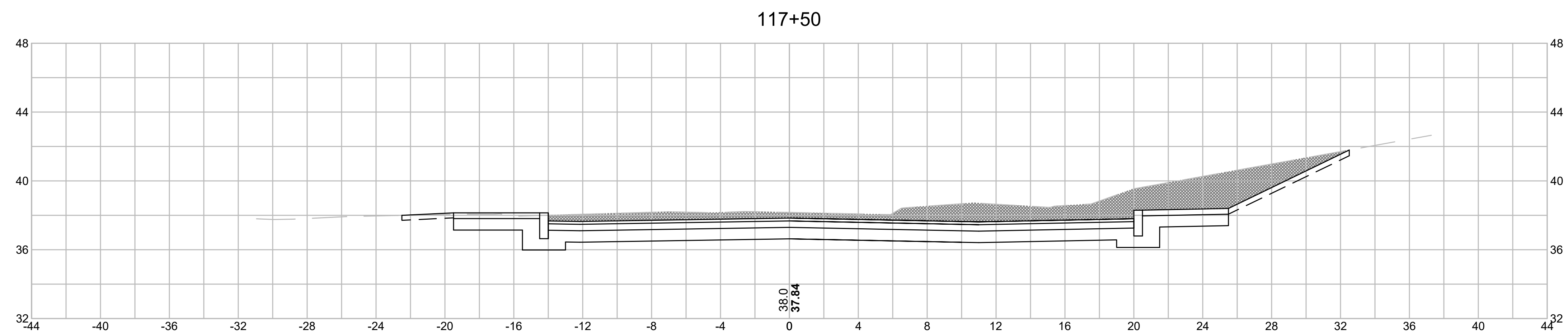
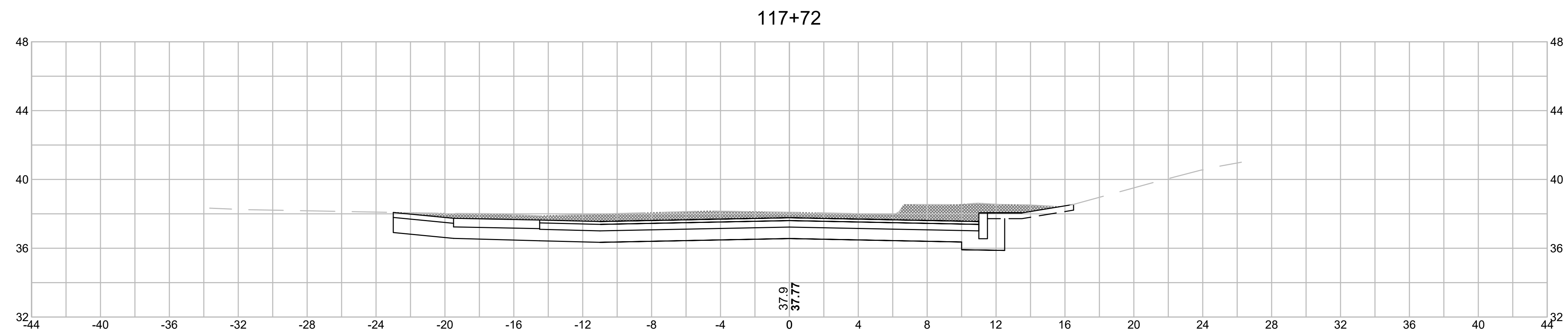
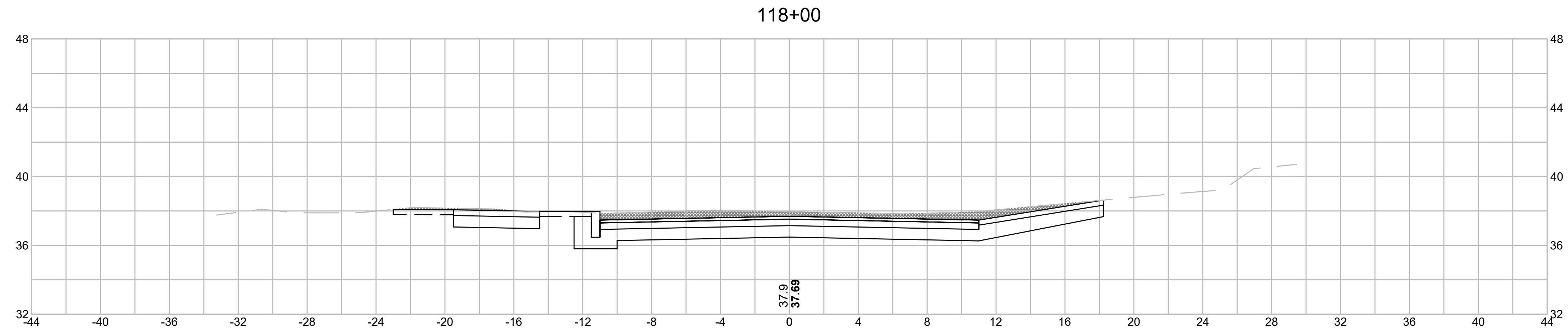

**BARNSTABLE
MARSTONS MILLS VILLAGE CENTER IMPROVEMENTS**

SHEET NO.	TOTAL SHEETS
90	109

**CROSS SECTIONS - SHEET 12674 - Cross Sections - 14 OF 33
ROUTE 149**

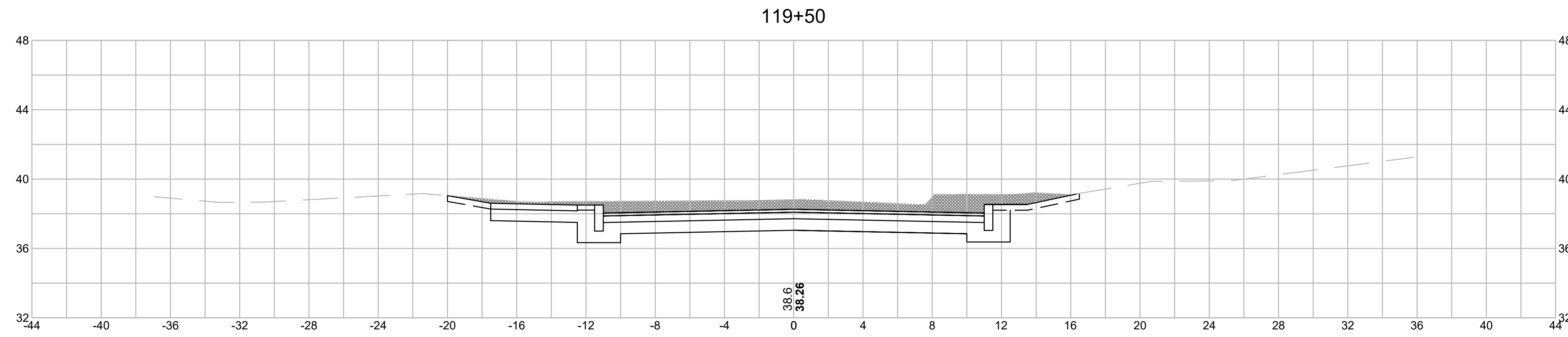

CUT: 17.5 SF
 FILL: 0.0 SF

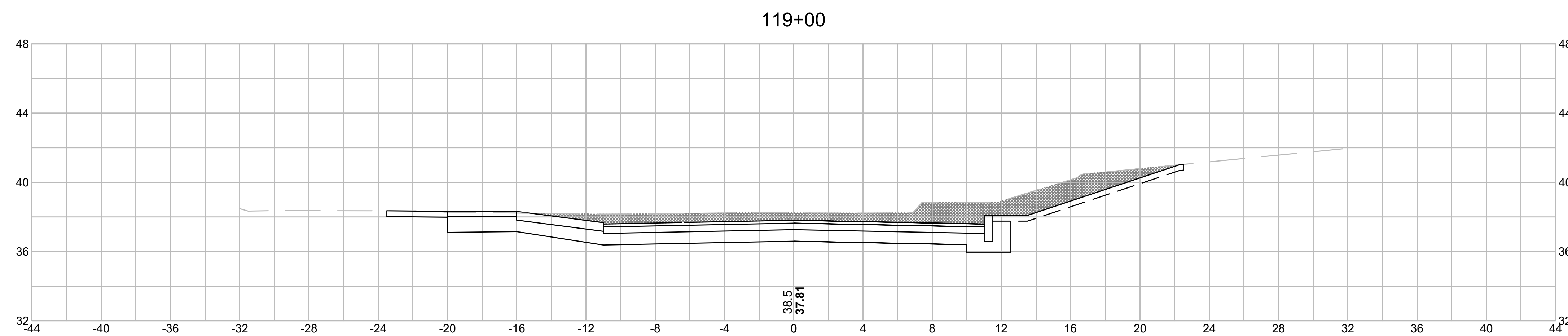

CUT: 24.5 SF
 FILL: 0.0 SF

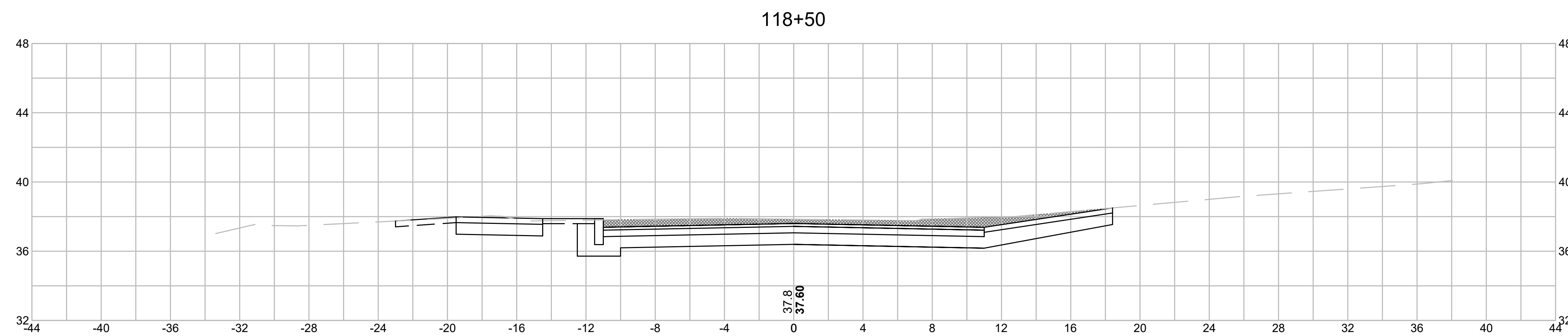

CUT: 10.0 SF
 FILL: 0.0 SF

BARNSTABLE
MARSTONS MILLS VILLAGE CENTER IMPROVEMENTS

SHEET NO.	TOTAL SHEETS
91	109

CROSS SECTIONS - SHEET 12674 - Cross Sections - 15 OF 33
ROUTE 149

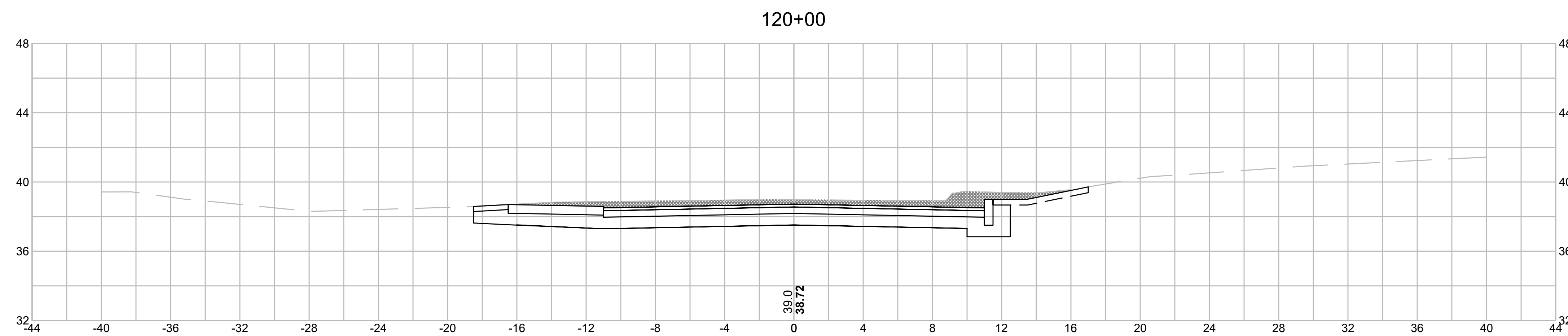
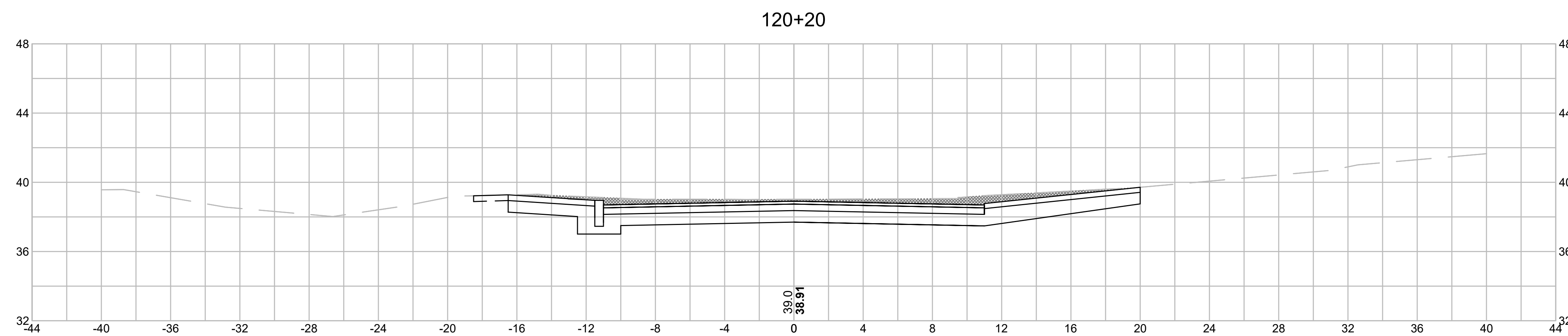
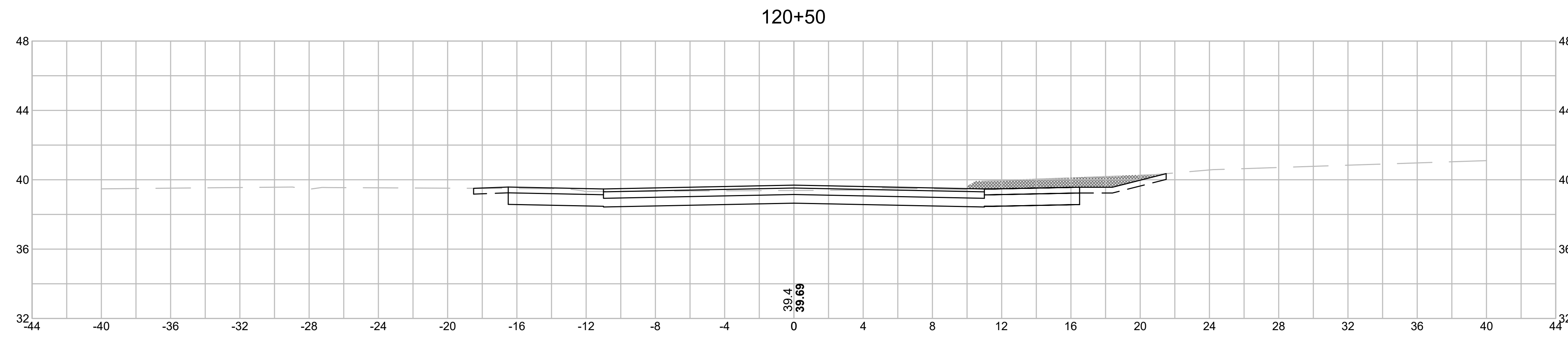

**BARNSTABLE
MARSTONS MILLS VILLAGE CENTER IMPROVEMENTS**

SHEET NO.	TOTAL SHEETS
92	109

**CROSS SECTIONS - SHEET 12674 - Cross Sections - 16 OF 33
ROUTE 149**

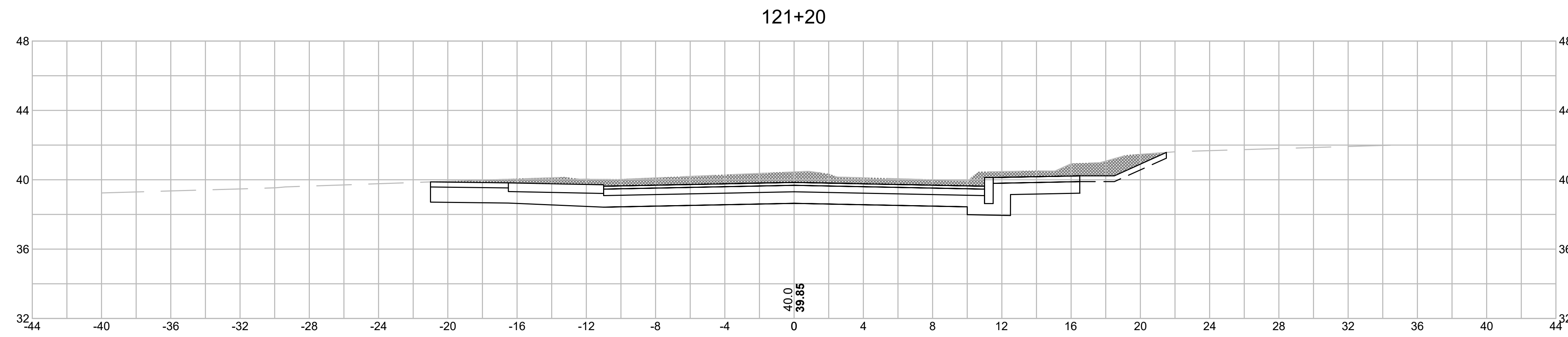

CUT: 17.5 SF
FILL: 0.0 SF

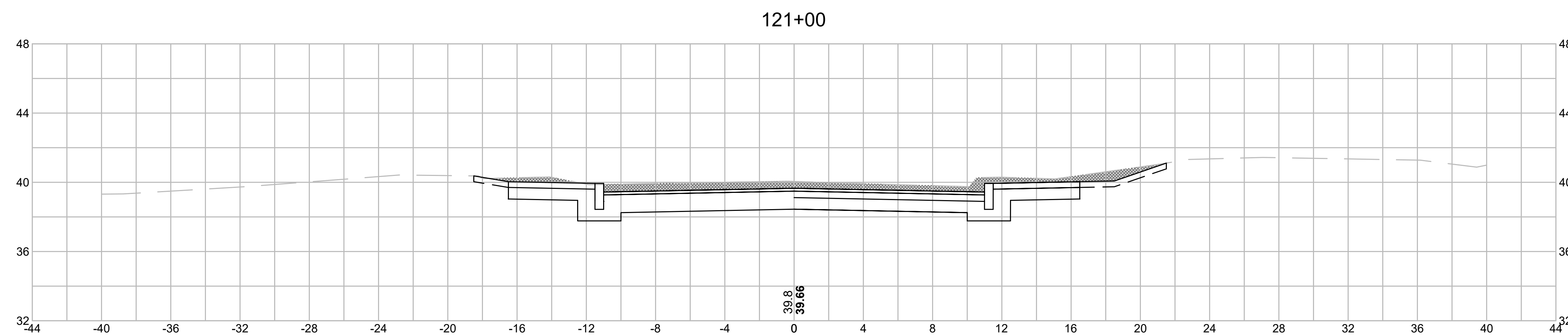

CUT: 13.0 SF
FILL: 0.0 SF

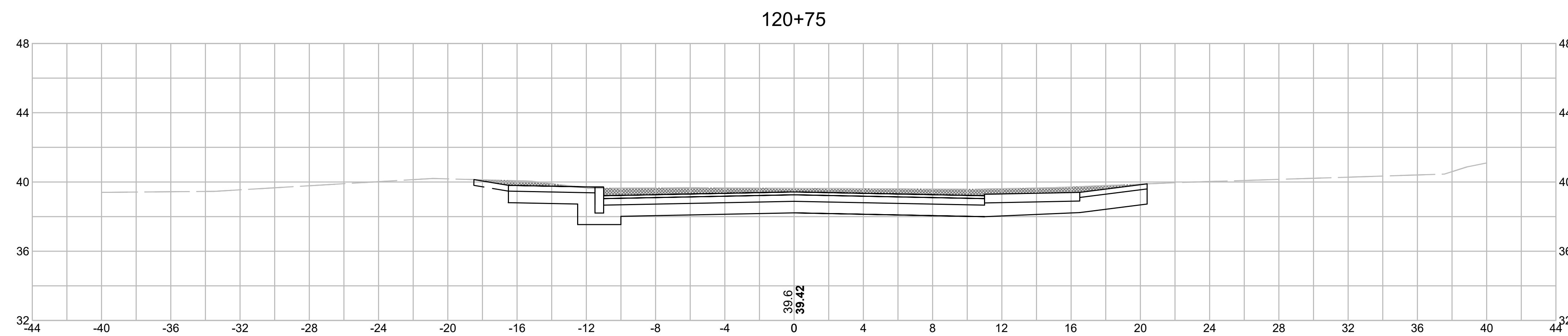

CUT: 10.5 SF
FILL: 0.0 SF

**BARNSTABLE
MARSTONS MILLS VILLAGE CENTER IMPROVEMENTS**

SHEET NO.	TOTAL SHEETS
93	109

**CROSS SECTIONS - SHEET 12674 - Cross Sections - 17 OF 33
ROUTE 149**

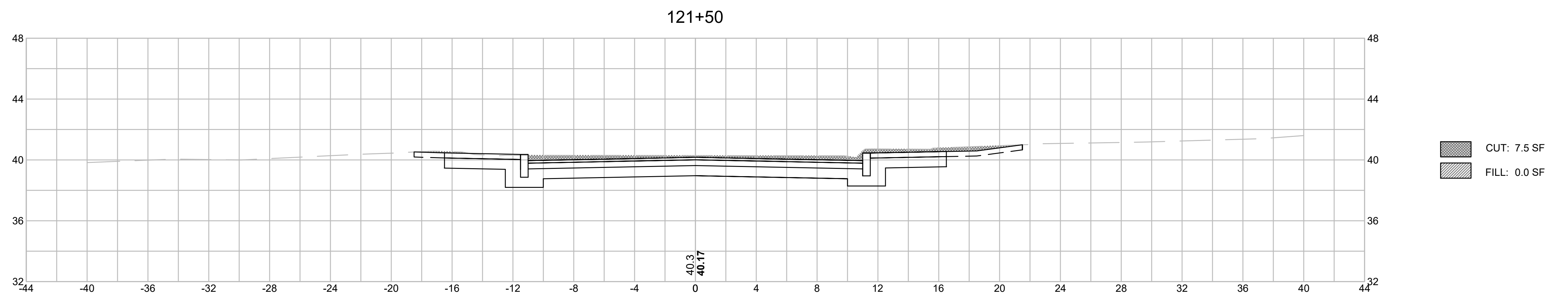
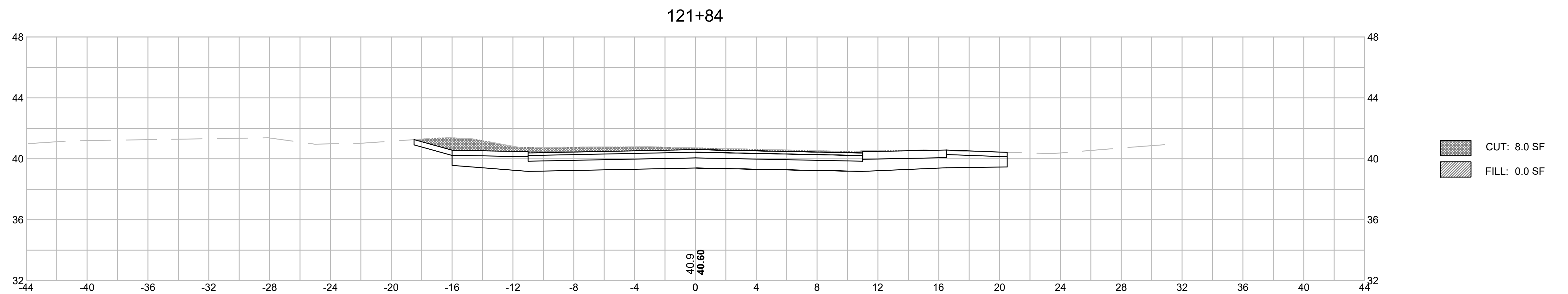
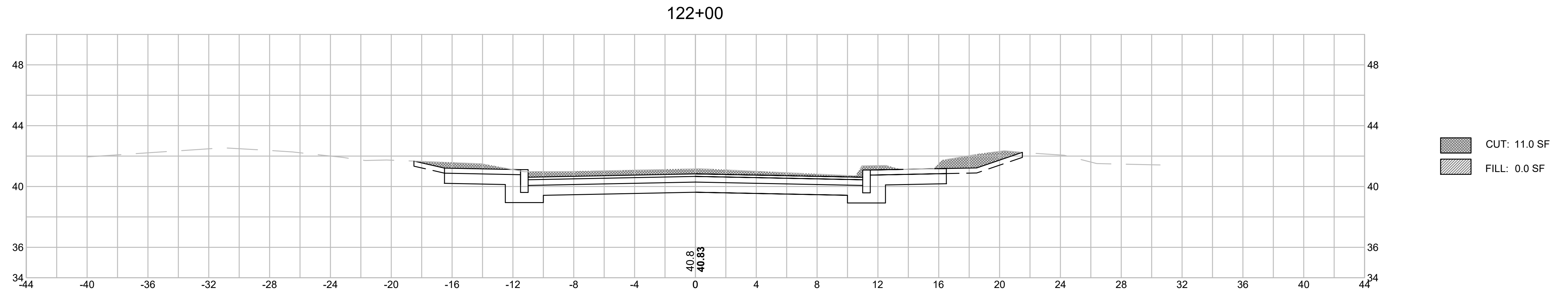

BARNSTABLE
MARSTONS MILLS VILLAGE CENTER IMPROVEMENTS

SHEET NO.	TOTAL SHEETS
94	109

CROSS SECTIONS - SHEET 12674 - Cross Sections - 18 OF 33
ROUTE 149

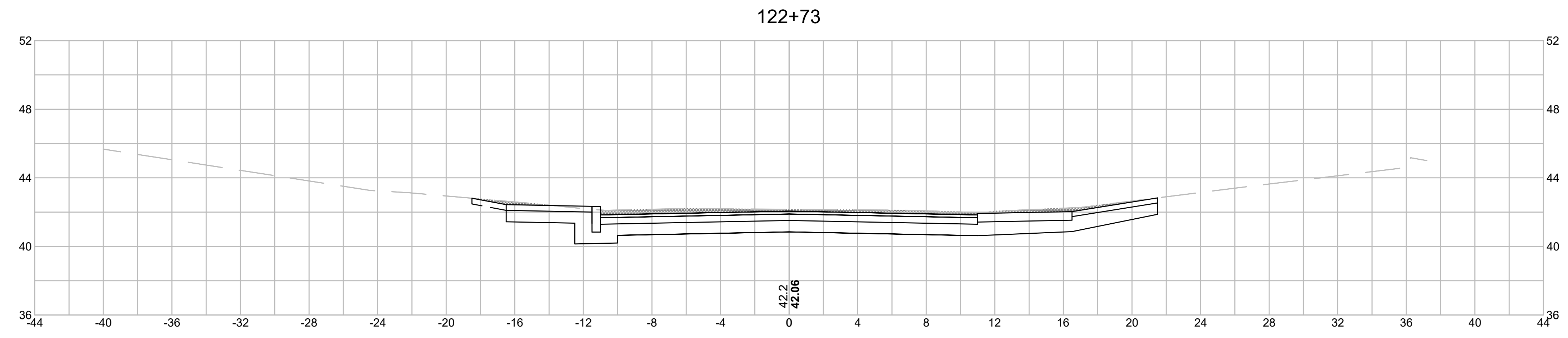

CUT: 6.0 SF
FILL: 0.0 SF

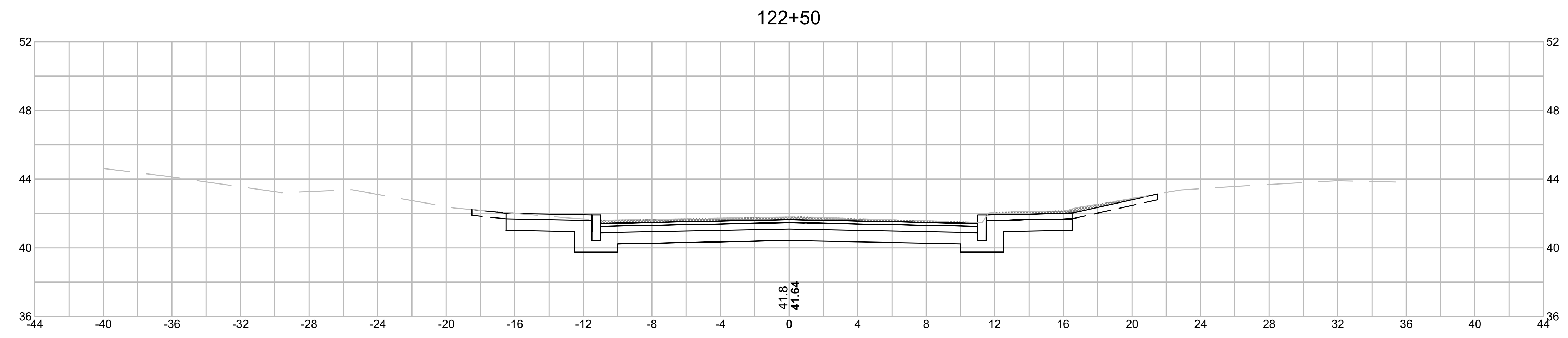

CUT: 4.5 SF
FILL: 0.0 SF

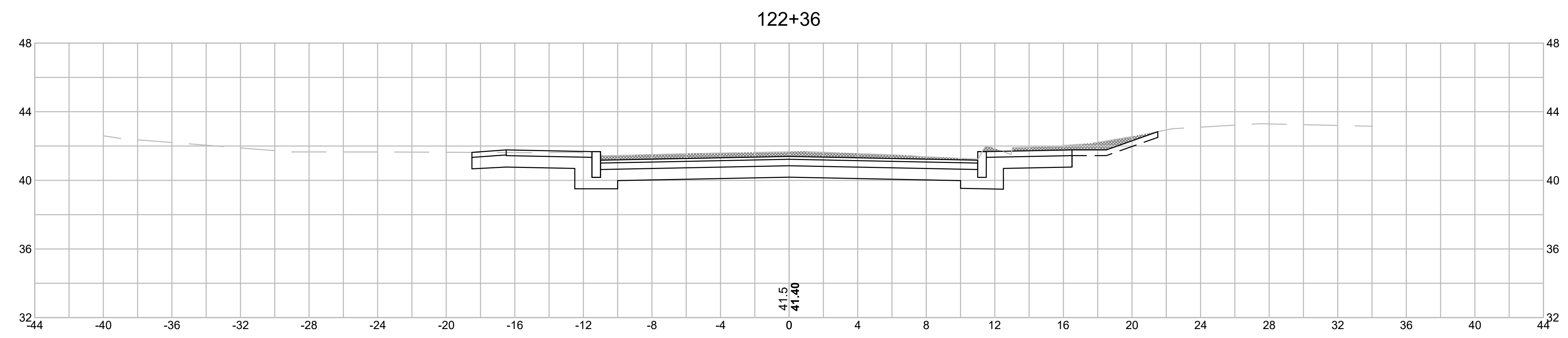

CUT: 7.5 SF
FILL: 0.0 SF

**BARNSTABLE
MARSTONS MILLS VILLAGE CENTER IMPROVEMENTS**

SHEET NO.	TOTAL SHEETS
95	109

**CROSS SECTIONS - SHEET 12674 - Cross Sections - 19 OF 33
ROUTE 149**

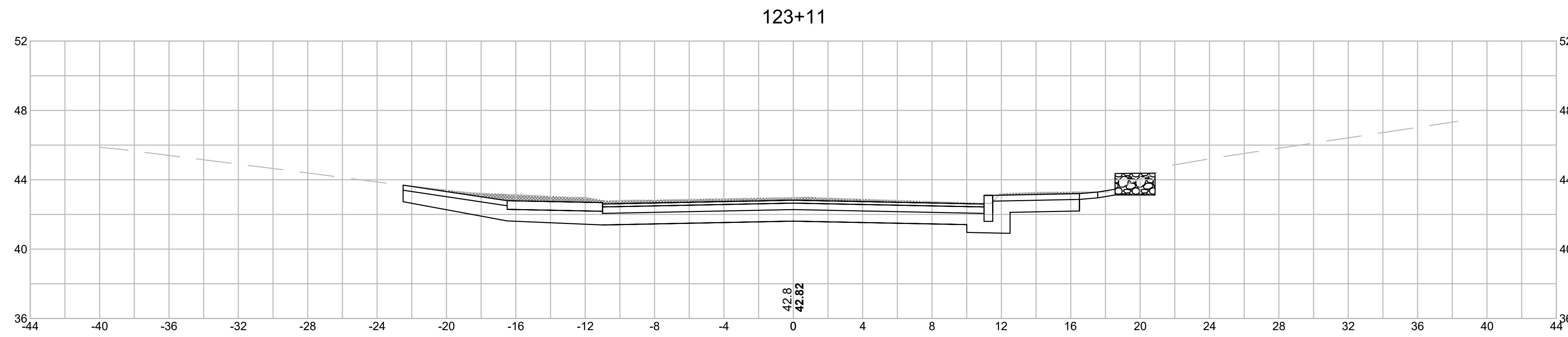

CUT: 6.0 SF
FILL: 0.0 SF

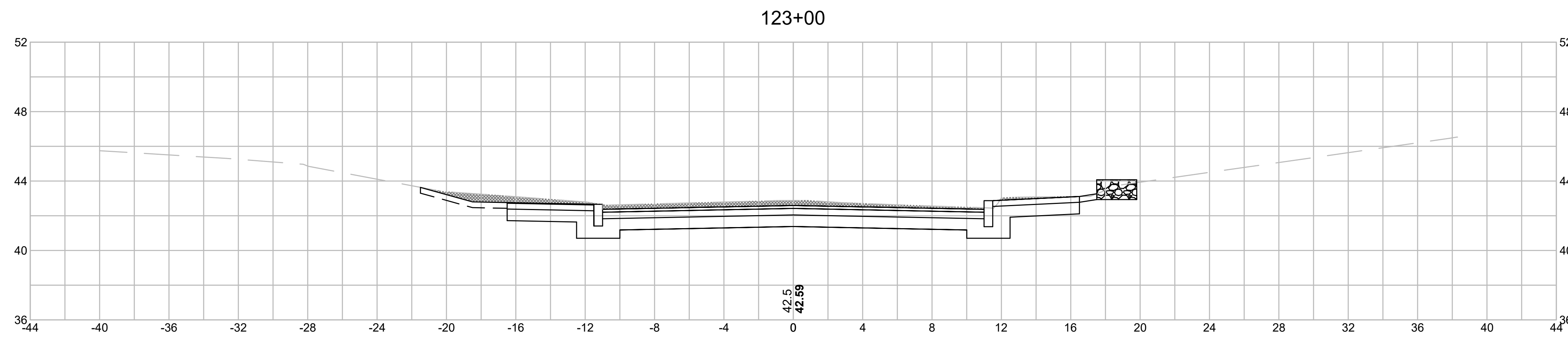

CUT: 8.0 SF
FILL: 0.0 SF

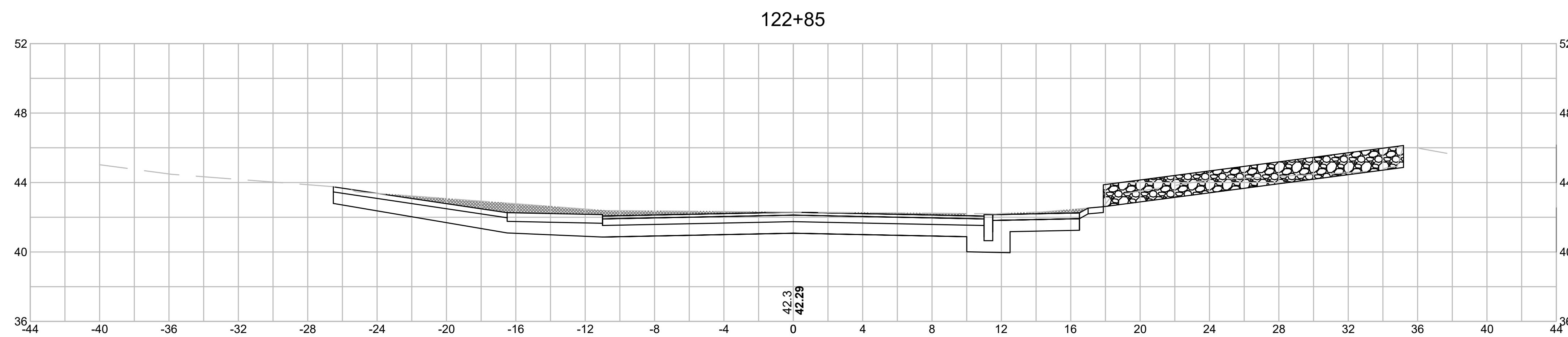

CUT: 7.0 SF
FILL: 0.0 SF

**BARNSTABLE
MARSTONS MILLS VILLAGE CENTER IMPROVEMENTS**

SHEET NO.	TOTAL SHEETS
96	109

**CROSS SECTIONS - SHEET 12674 - Cross Sections - 20 OF 33
ROUTE 149**

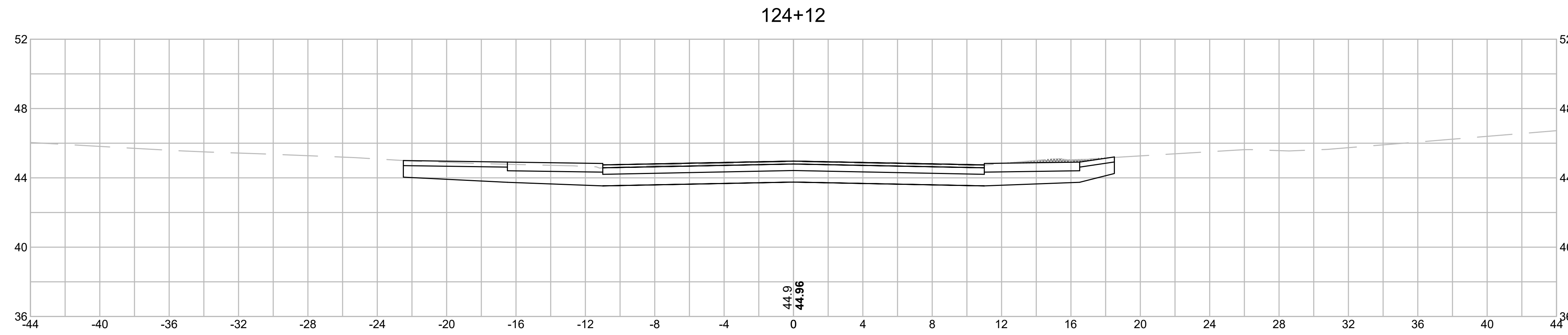

CUT: 0.5 SF
FILL: 0.0 SF

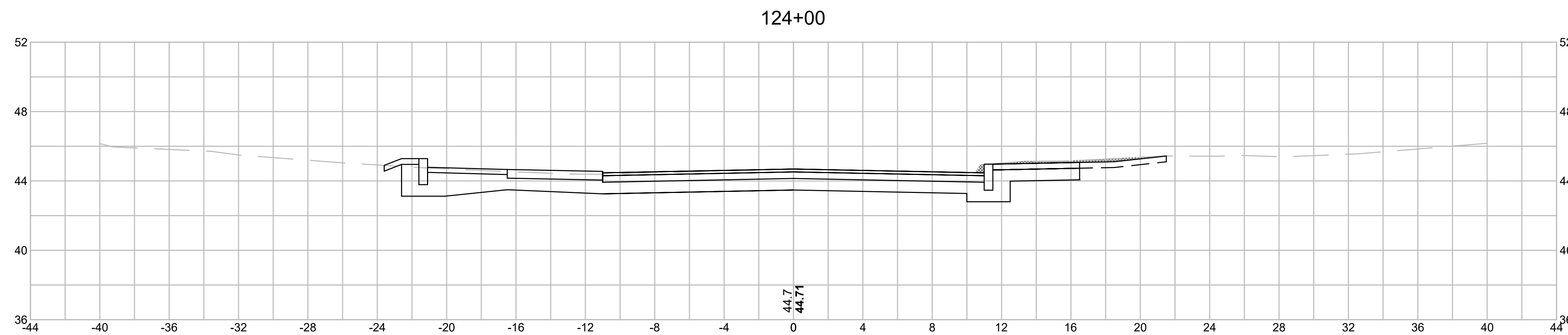

CUT: 1.0 SF
FILL: 0.0 SF

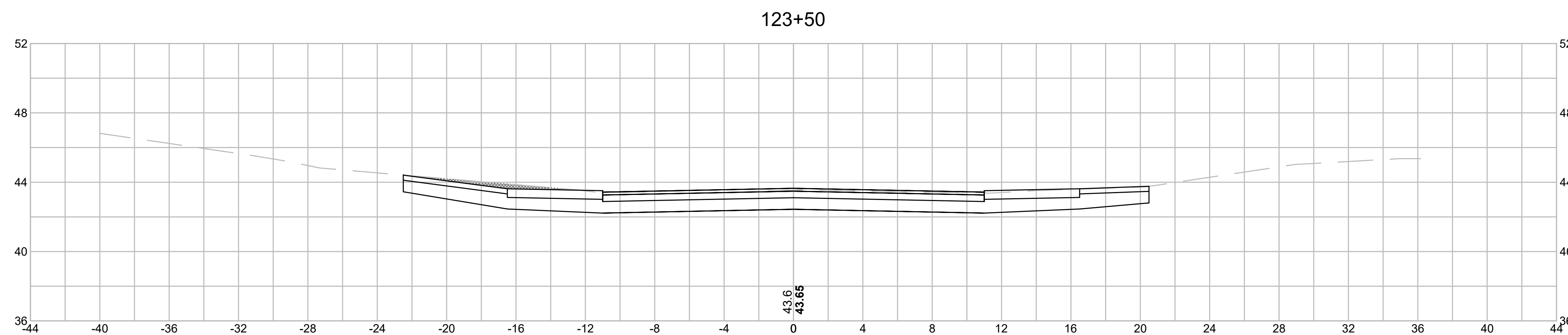

CUT: 1.5 SF
FILL: 0.0 SF

**BARNSTABLE
MARSTONS MILLS VILLAGE CENTER IMPROVEMENTS**

SHEET NO.	TOTAL SHEETS
97	109

**CROSS SECTIONS - SHEET 12674 - Cross Sections - 21 OF 33
ROUTE 149**

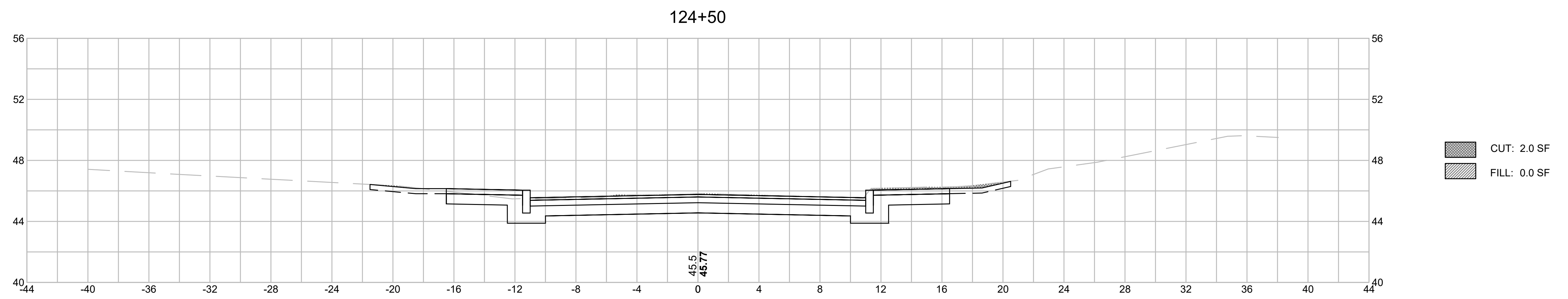
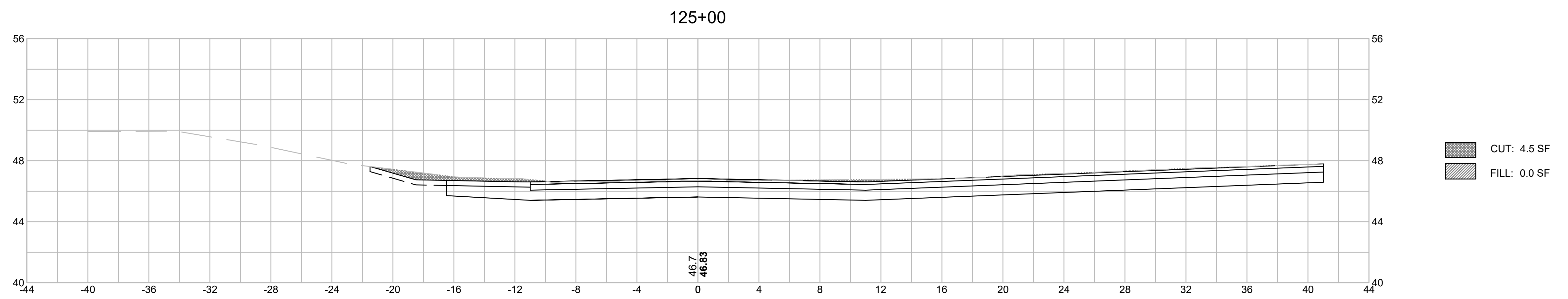

BARNSTABLE
MARSTONS MILLS VILLAGE CENTER IMPROVEMENTS

SHEET NO.	TOTAL SHEETS
98	109

CROSS SECTIONS - SHEET 12674 - Cross Sections - 22 OF 33
MAIN STREET

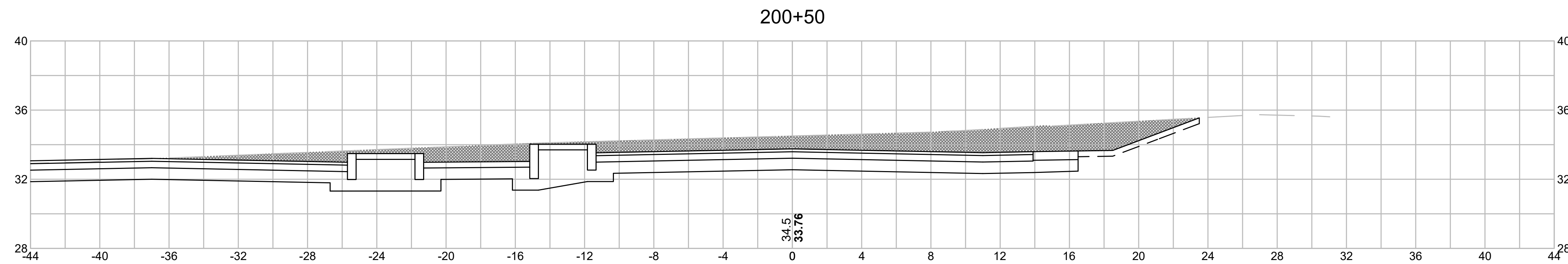
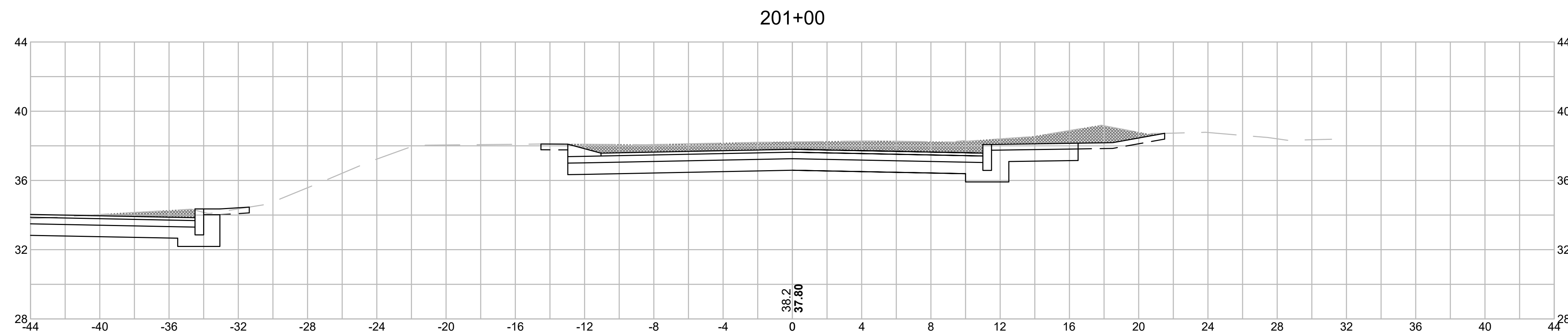
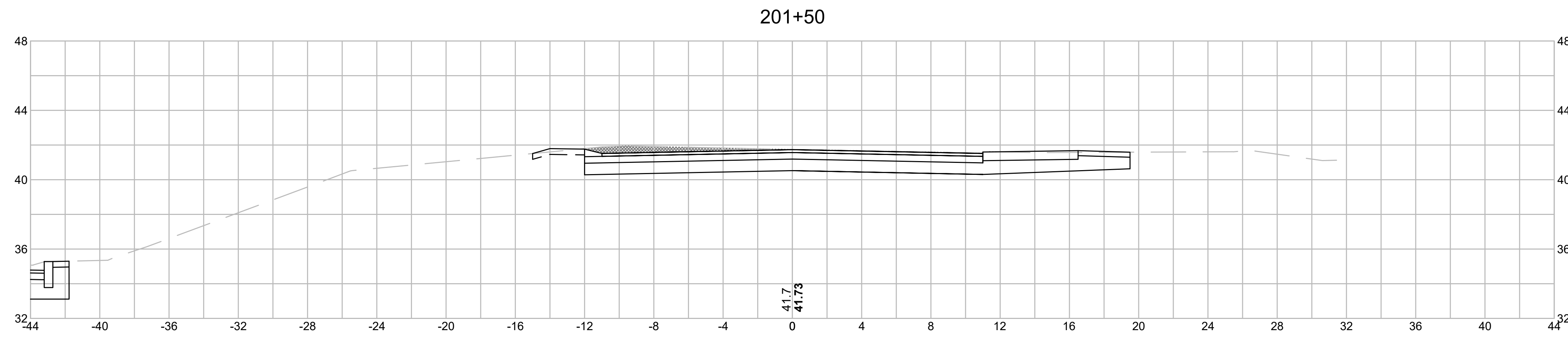

BARNSTABLE
MARSTONS MILLS VILLAGE CENTER IMPROVEMENTS

SHEET NO.	TOTAL SHEETS
99	109

CROSS SECTIONS - SHEET 12674 - Cross Sections - 23 OF 33
MAIN STREET

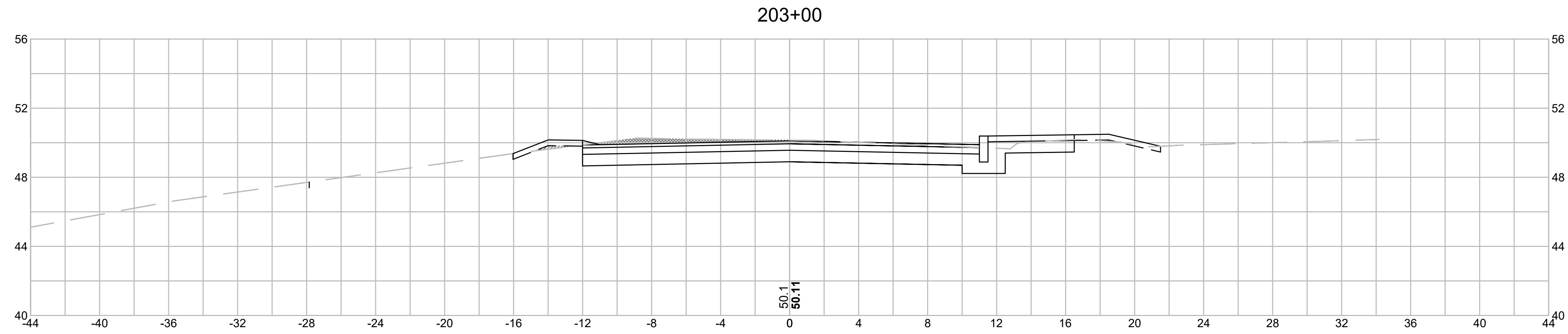

CUT: 2.0 SF
FILL: 0.5 SF

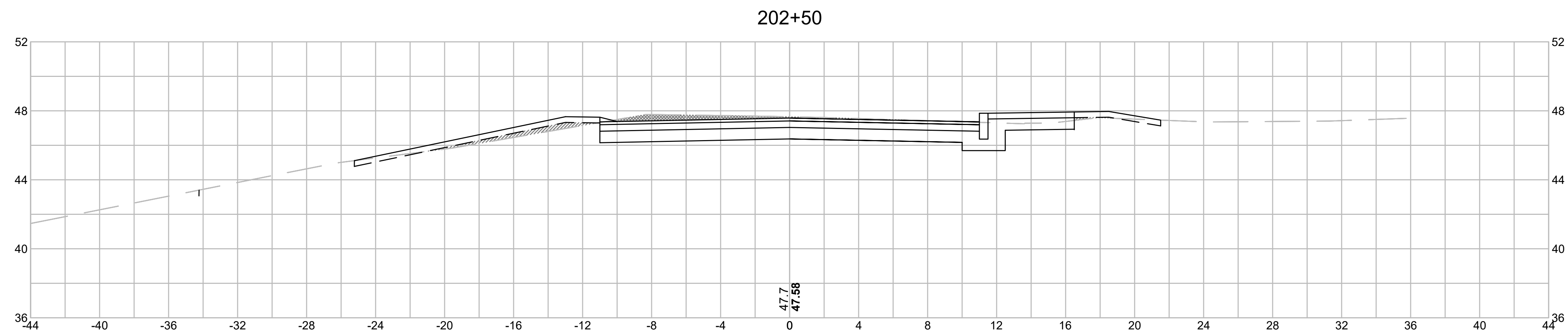

CUT: 3.0 SF
FILL: 2.0 SF

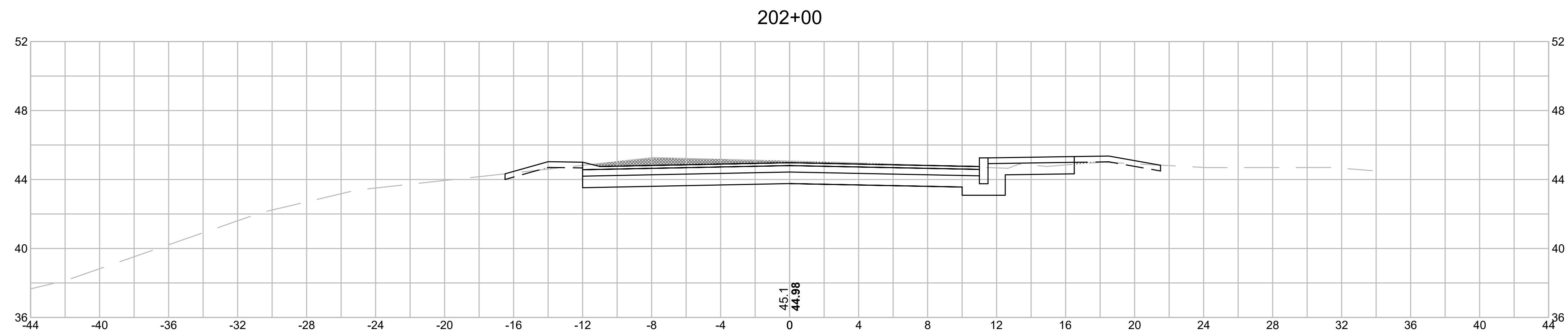

CUT: 3.5 SF
FILL: 0.0 SF

**BARNSTABLE
MARSTONS MILLS VILLAGE CENTER IMPROVEMENTS**

SHEET NO.	TOTAL SHEETS
100	109

**CROSS SECTIONS - SHEET 12674 - Cross Sections - 24 OF 33
MAIN STREET**

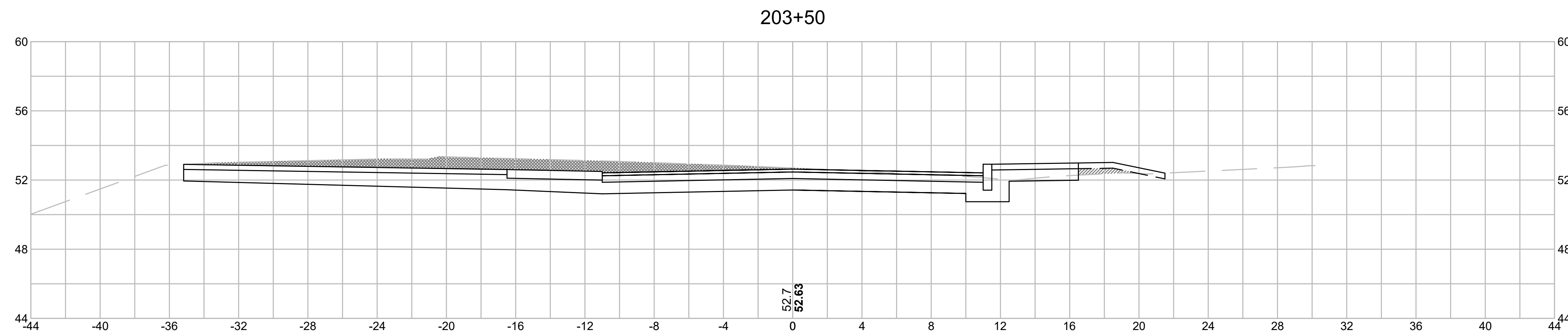
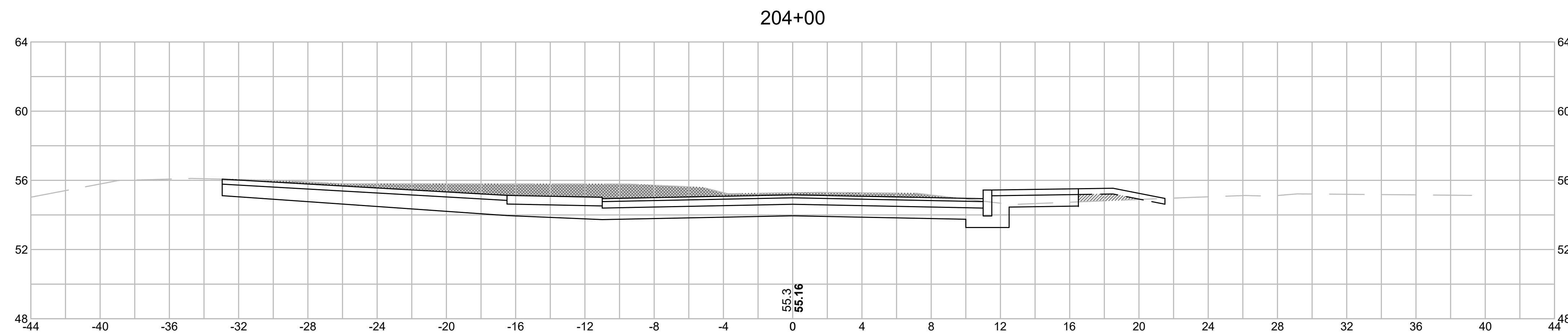
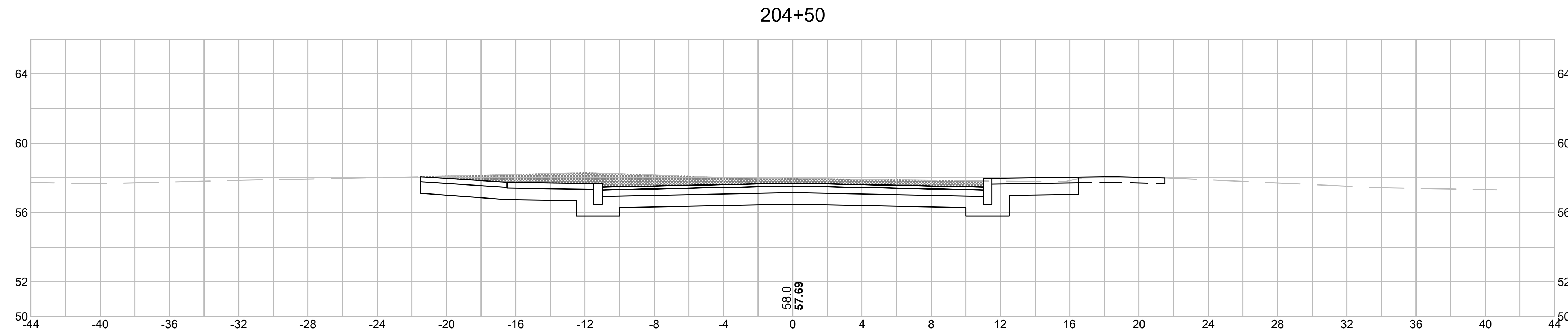

**BARNSTABLE
MARSTONS MILLS VILLAGE CENTER IMPROVEMENTS**

SHEET NO.	TOTAL SHEETS
101	109

**CROSS SECTIONS - SHEET 12674 - Cross Sections - 25 OF 33
MAIN STREET**

REV #	DATE
△	3/13/19

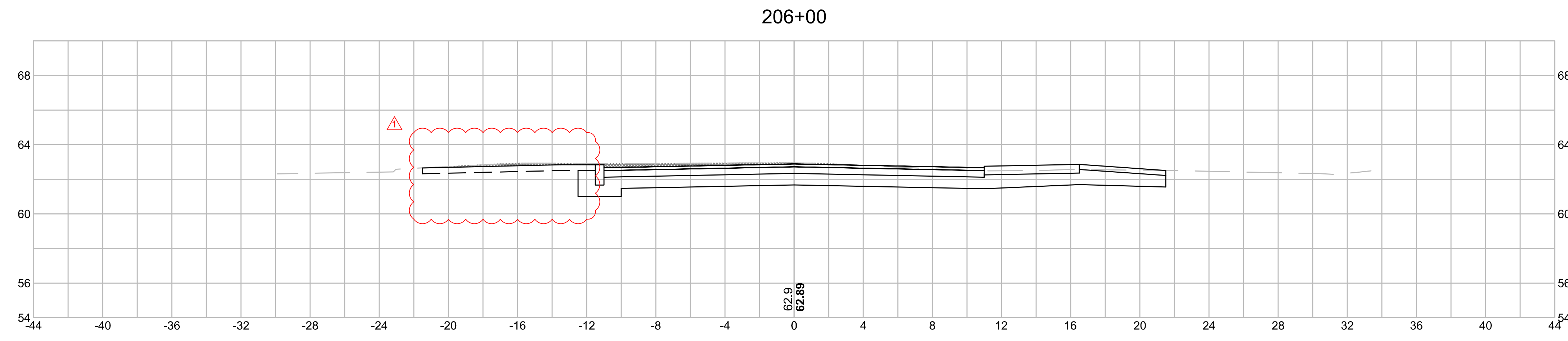

CUT: 2.0 SF
 FILL: 0.0 SF

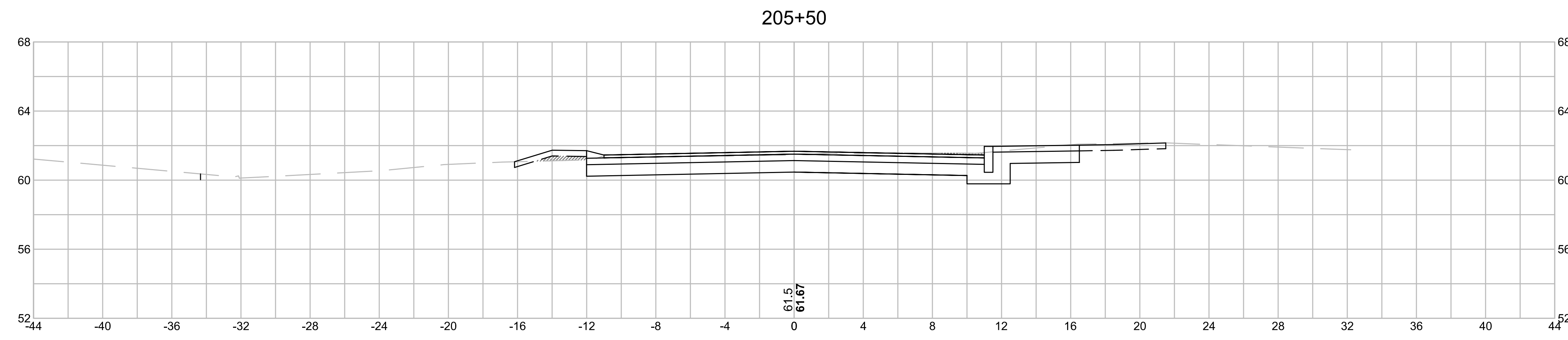

CUT: 0.5 SF
 FILL: 0.5 SF

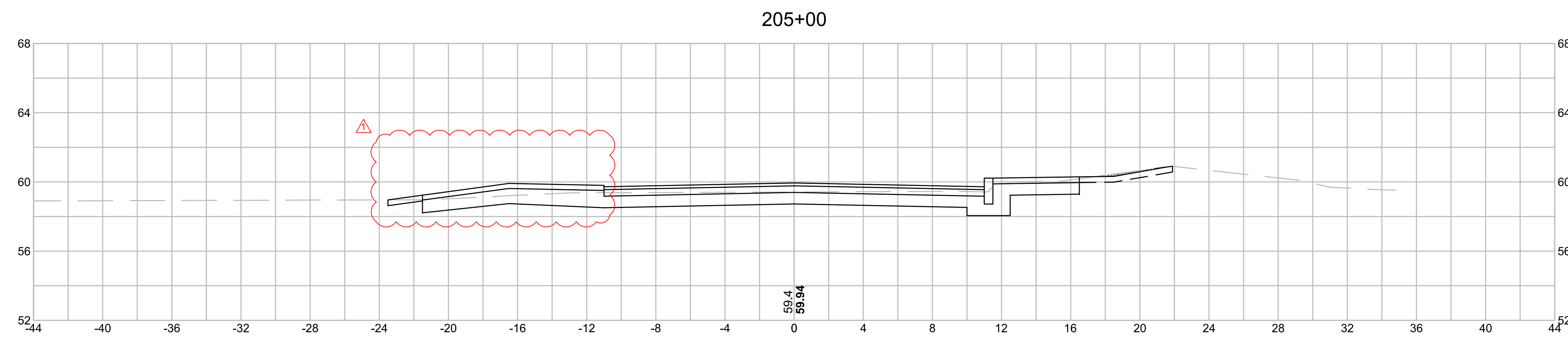

CUT: 0.5 SF
 FILL: 0.0 SF

**BARNSTABLE
MARSTONS MILLS VILLAGE CENTER IMPROVEMENTS**

SHEET NO.	TOTAL SHEETS
102	109

**CROSS SECTIONS - SHEET 12674 - Cross Sections - 26 OF 33
MAIN STREET**

REV #	DATE
△	3/13/19

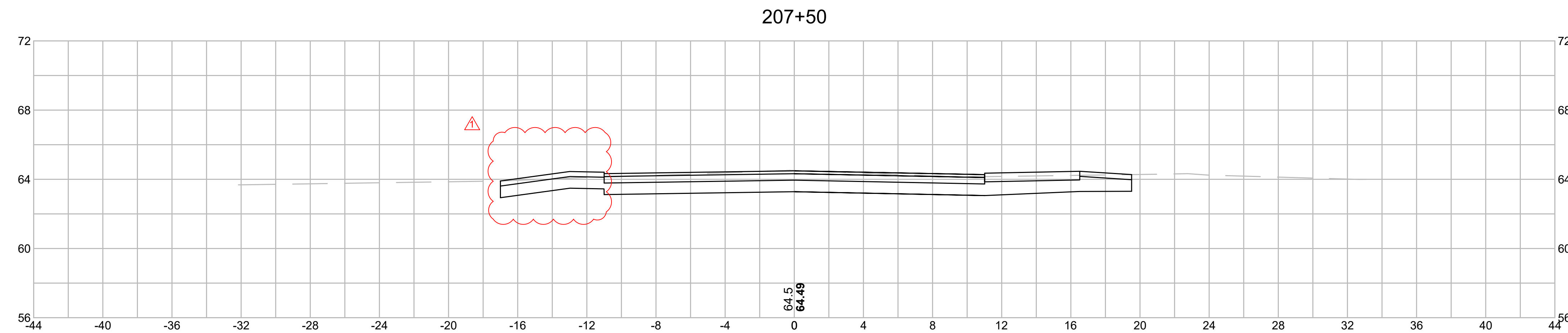

CUT: 0.0 SF
 FILL: 0.0 SF

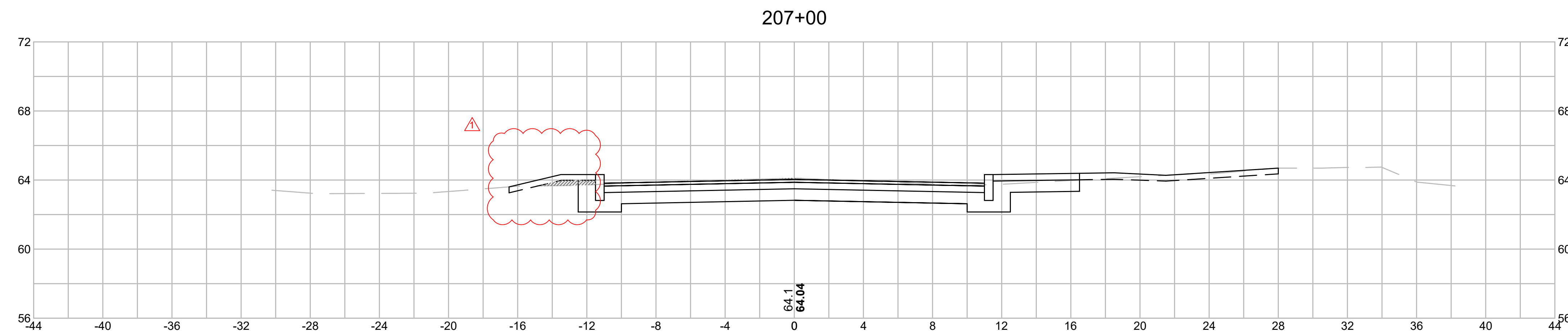

CUT: 0.5 SF
 FILL: 1.0 SF △

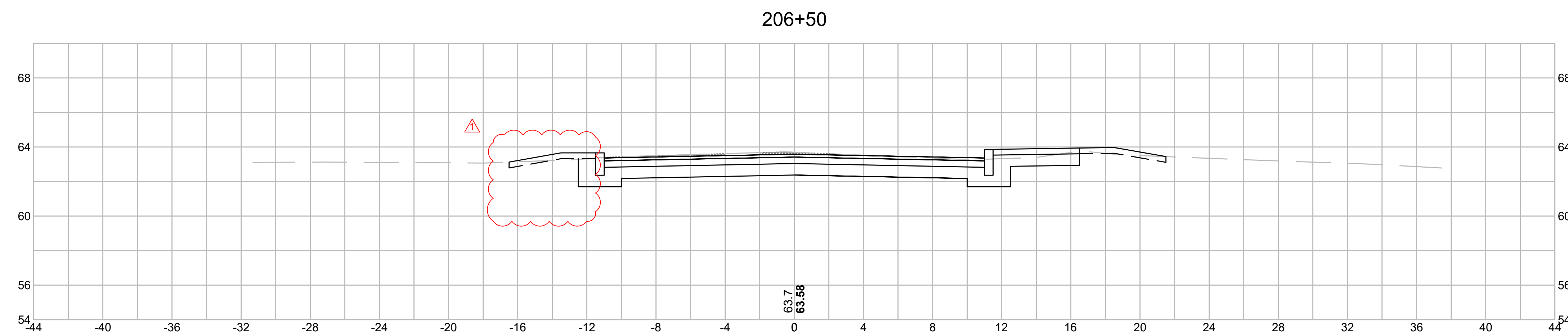

CUT: 1.0 SF
 FILL: 0.0 SF △

**BARNSTABLE
MARSTONS MILLS VILLAGE CENTER IMPROVEMENTS**

SHEET NO.	TOTAL SHEETS
103	109

**CROSS SECTIONS - SHEET 12674 - Cross Sections - 27 OF 33
MAIN STREET**

REV #	DATE
△	3/13/19

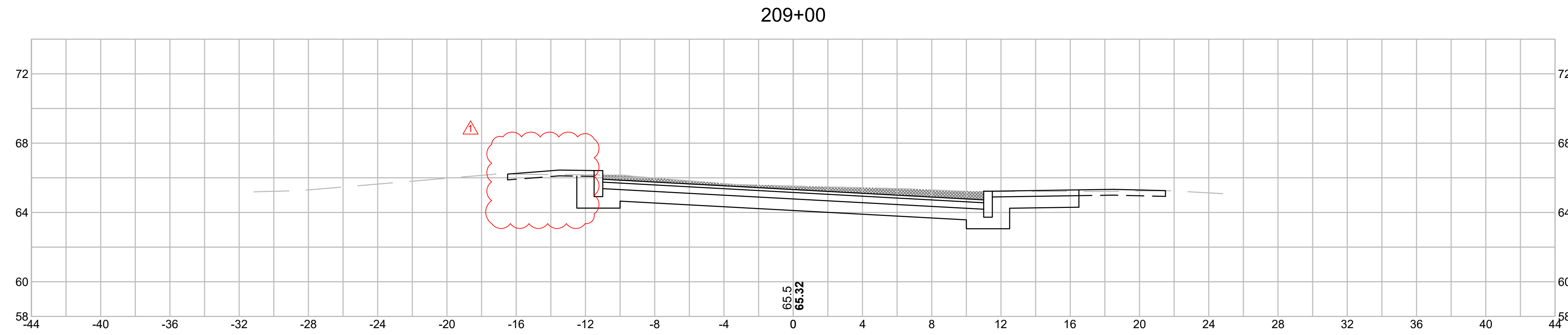

CUT: 6.0 SF
 FILL: 0.0 SF

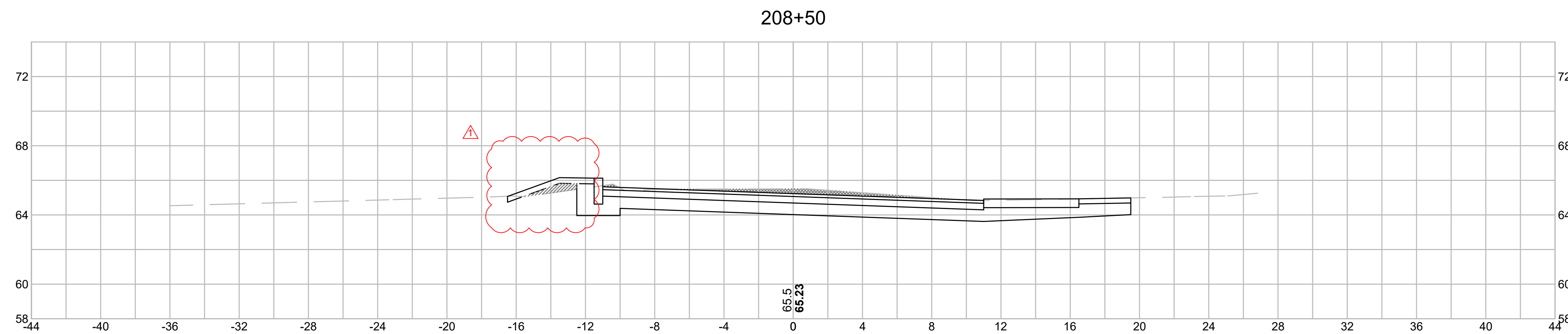

CUT: 2.5 SF
 FILL: 1.0 SF △

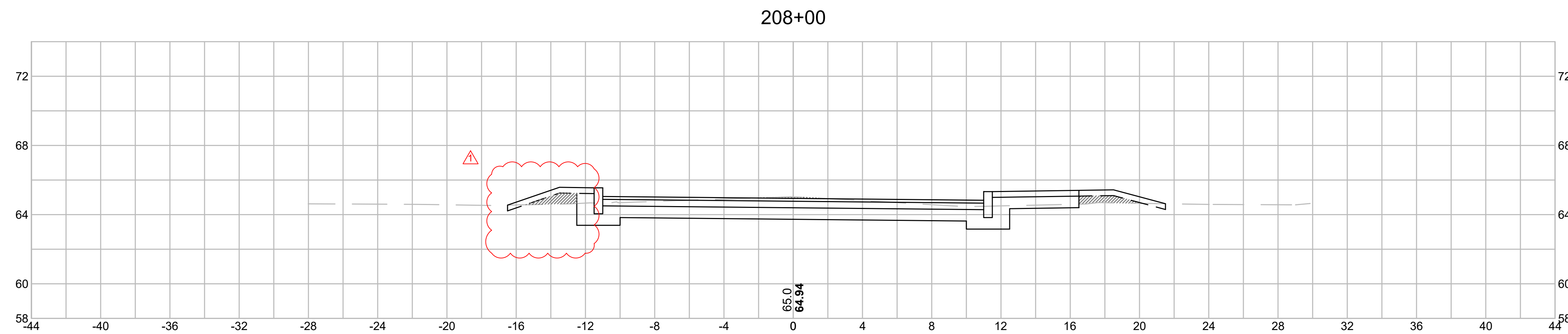

CUT: 0.5 SF
 FILL: 2.5 SF △

**BARNSTABLE
MARSTONS MILLS VILLAGE CENTER IMPROVEMENTS**

SHEET NO.	TOTAL SHEETS
104	109

**CROSS SECTIONS - SHEET 12674 - Cross Sections - 28 OF 33
MAIN STREET**

REV #	DATE
△	3/13/19

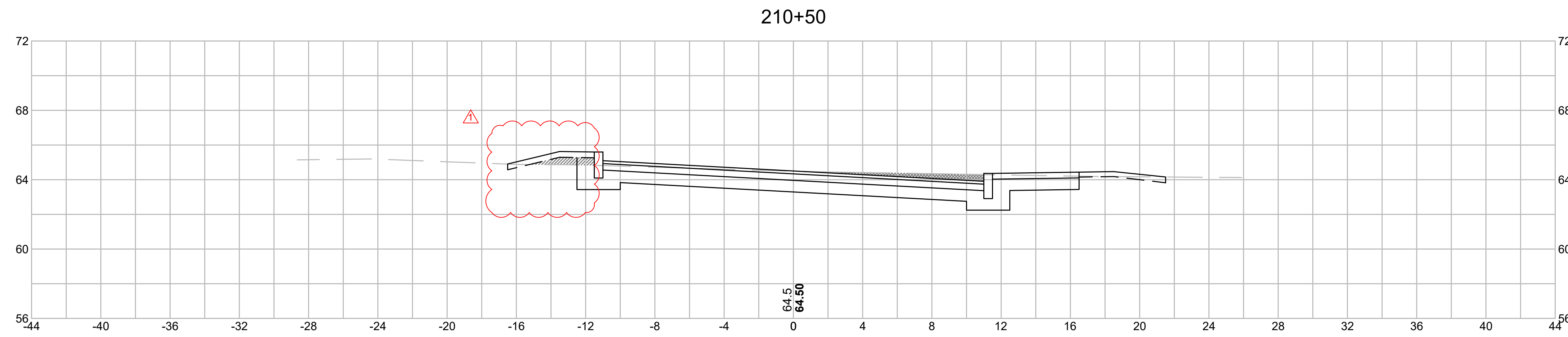

CUT: 2.0 SF
FILL: 1.0 SF

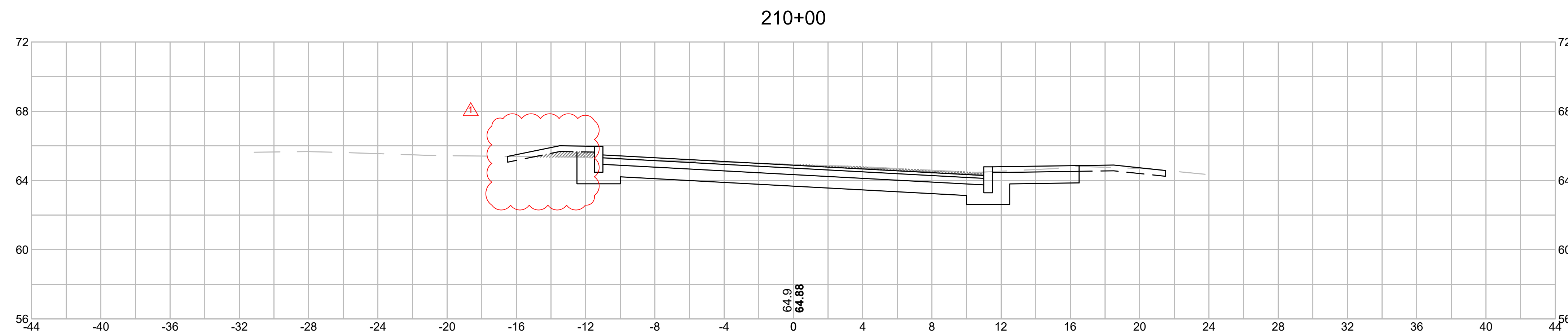

CUT: 1.5 SF
FILL: 1.0 SF

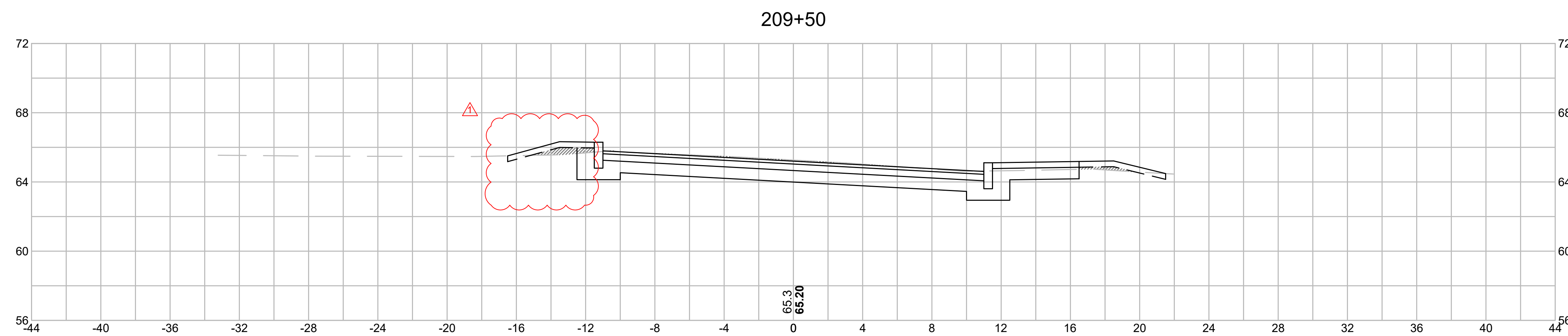

CUT: 1.0 SF
FILL: 1.5 SF △

BARNSTABLE
MARSTONS MILLS VILLAGE CENTER IMPROVEMENTS

SHEET NO.	TOTAL SHEETS
105	109

CROSS SECTIONS - SHEET 12674 - Cross Sections - 29 OF 33
MAIN STREET

REV #	DATE
△	3/13/19

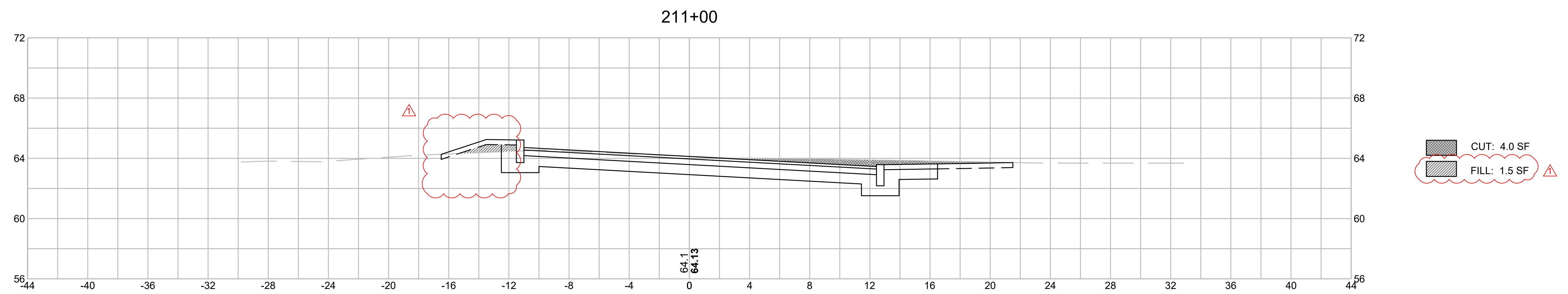

**BARNSTABLE
MARSTONS MILLS VILLAGE CENTER IMPROVEMENTS**

SHEET NO.	TOTAL SHEETS
106	109

**CROSS SECTIONS - SHEET 12674 - Cross Sections - 30 OF 33
RIVER ROAD**

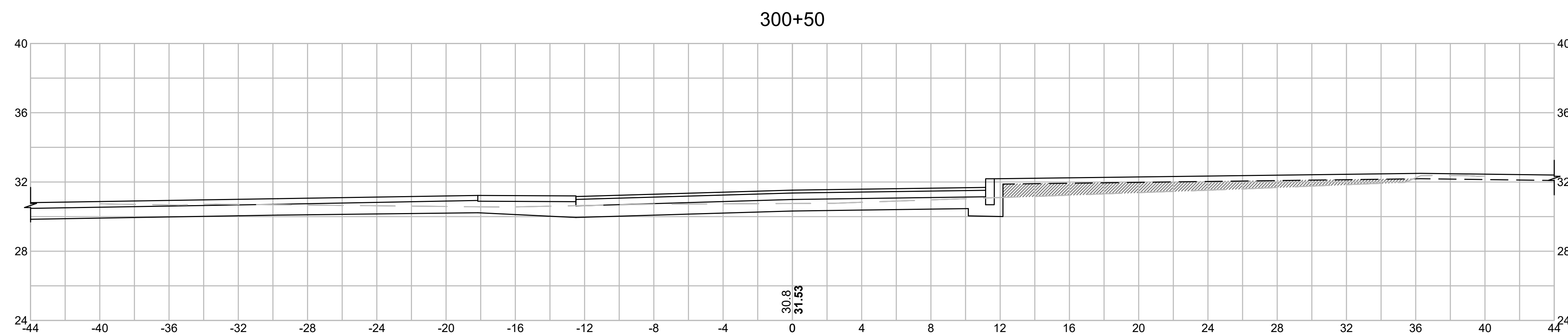
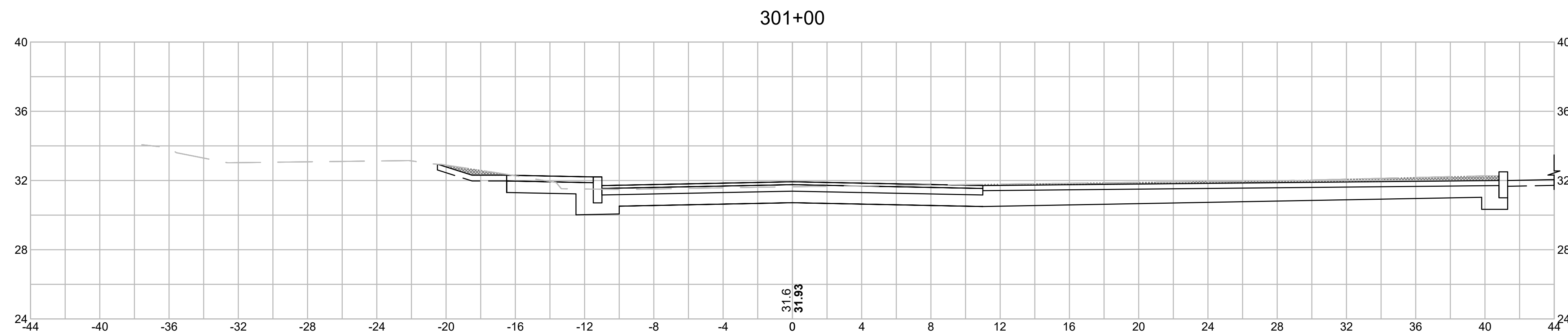
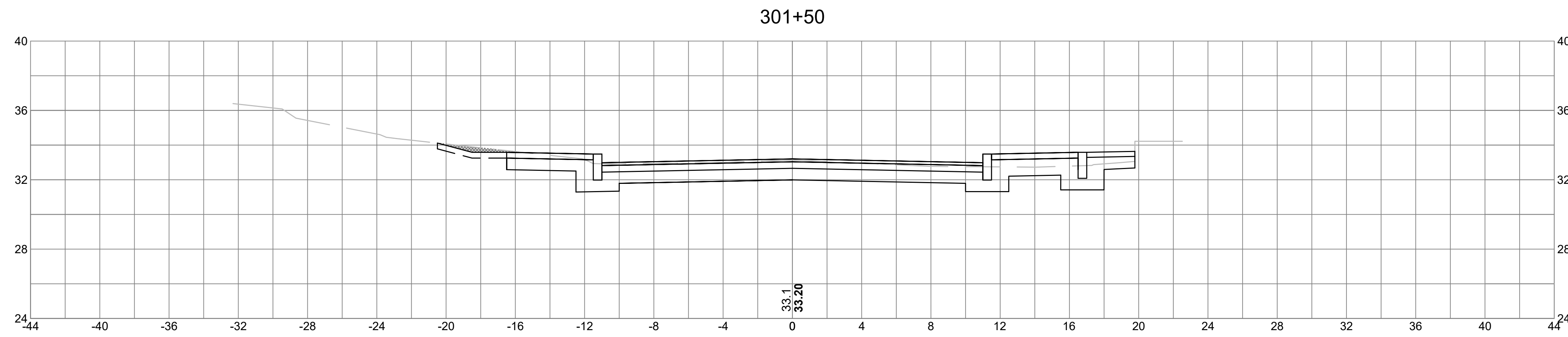

BARNSTABLE
MARSTONS MILLS VILLAGE CENTER IMPROVEMENTS

SHEET NO.	TOTAL SHEETS
107	109

CROSS SECTIONS - SHEET 12674 - Cross Sections - 31 OF 33
RIVER ROAD

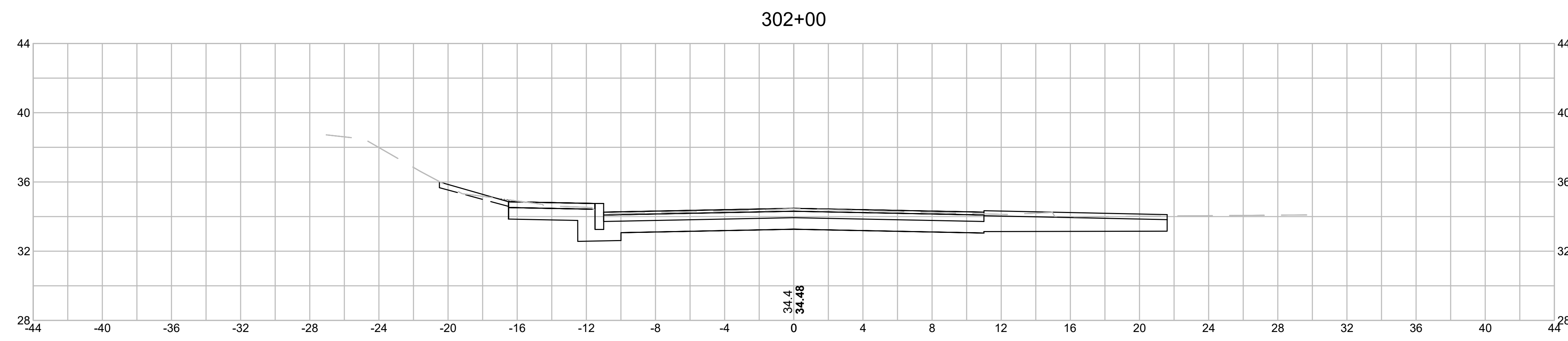
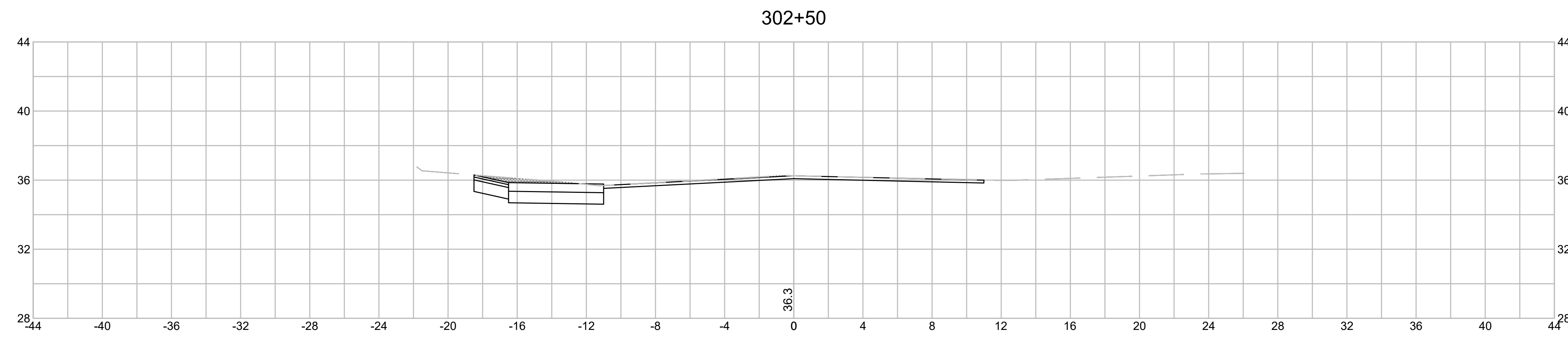
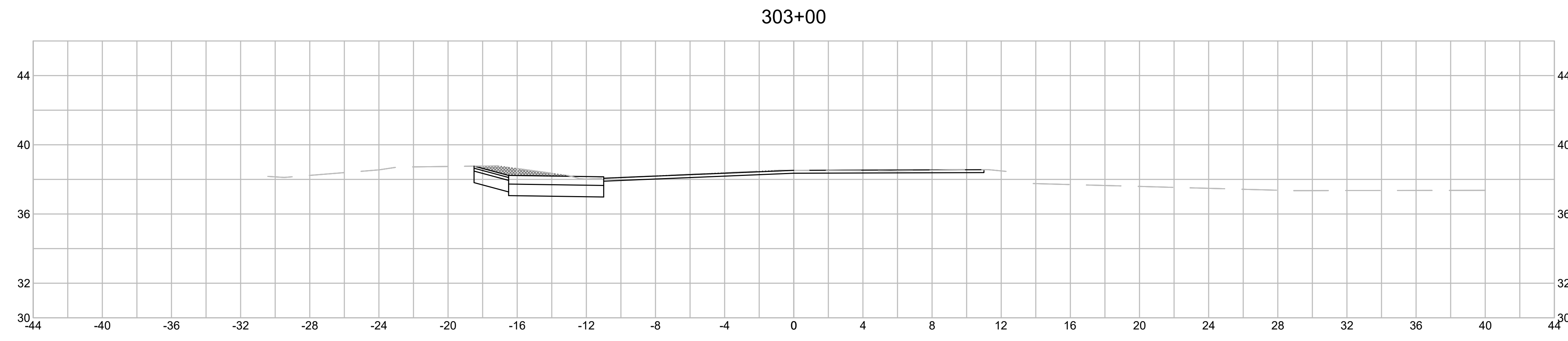

**BARNSTABLE
MARSTONS MILLS VILLAGE CENTER IMPROVEMENTS**

SHEET NO.	TOTAL SHEETS
108	109

**CROSS SECTIONS - SHEET 32 OF 33
RIVER ROAD**

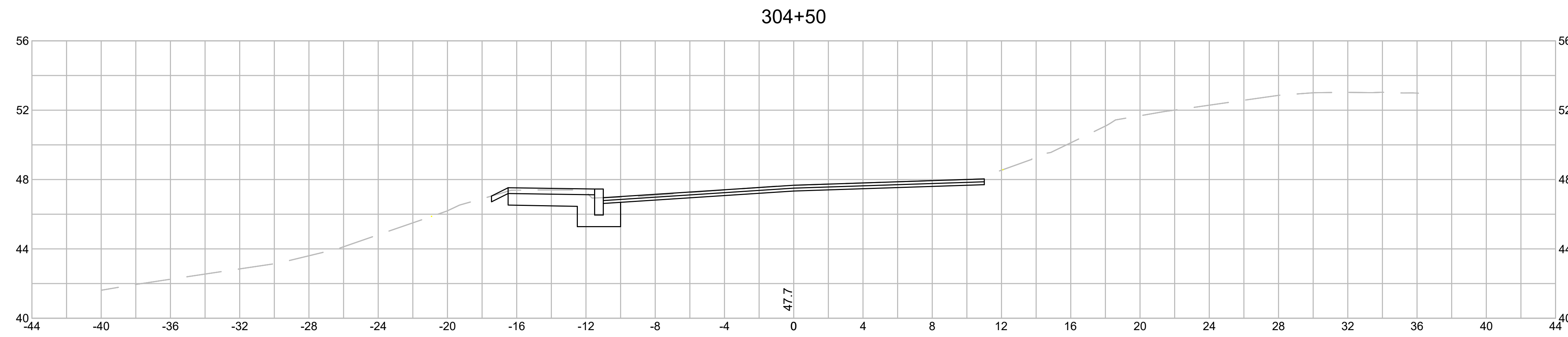

CUT: 0.0 SF
 FILL: 0.0 SF

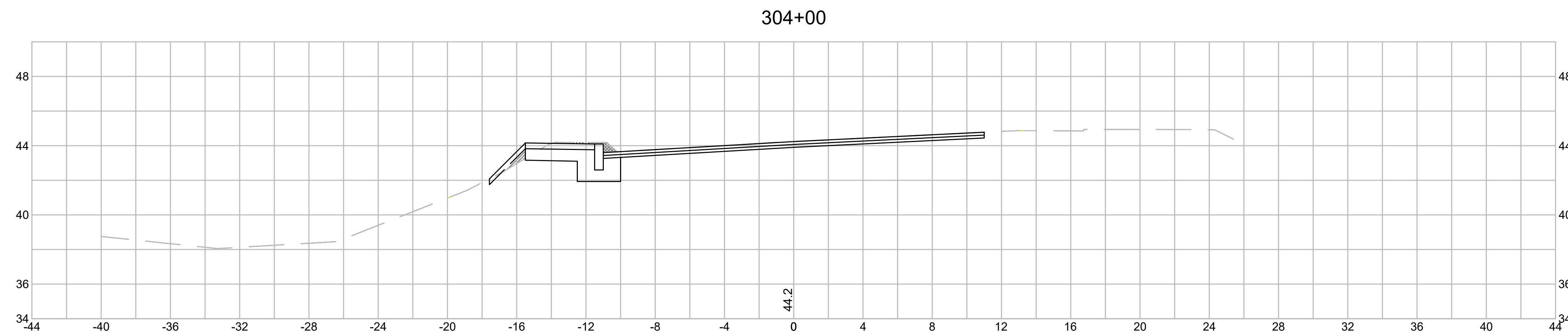

CUT: 0.5 SF
 FILL: 0.5 SF

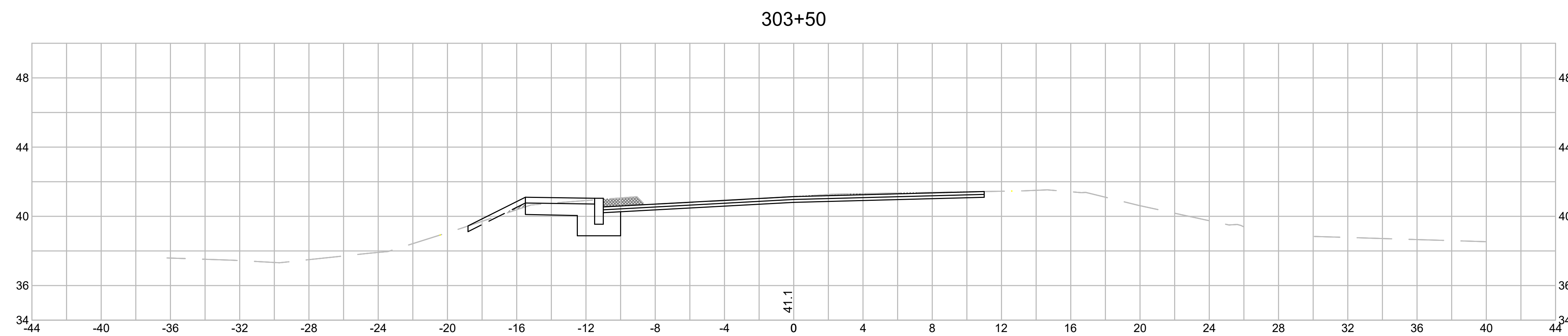

CUT: 1.5 SF
 FILL: 0.0 SF

BARNSTABLE
MARSTONS MILLS VILLAGE CENTER IMPROVEMENTS

SHEET NO.	TOTAL SHEETS
109	109

CROSS SECTIONS - SHEET 33 OF 33
RIVER ROAD

